

lichtgitter

 lichtgitter

MANUAL

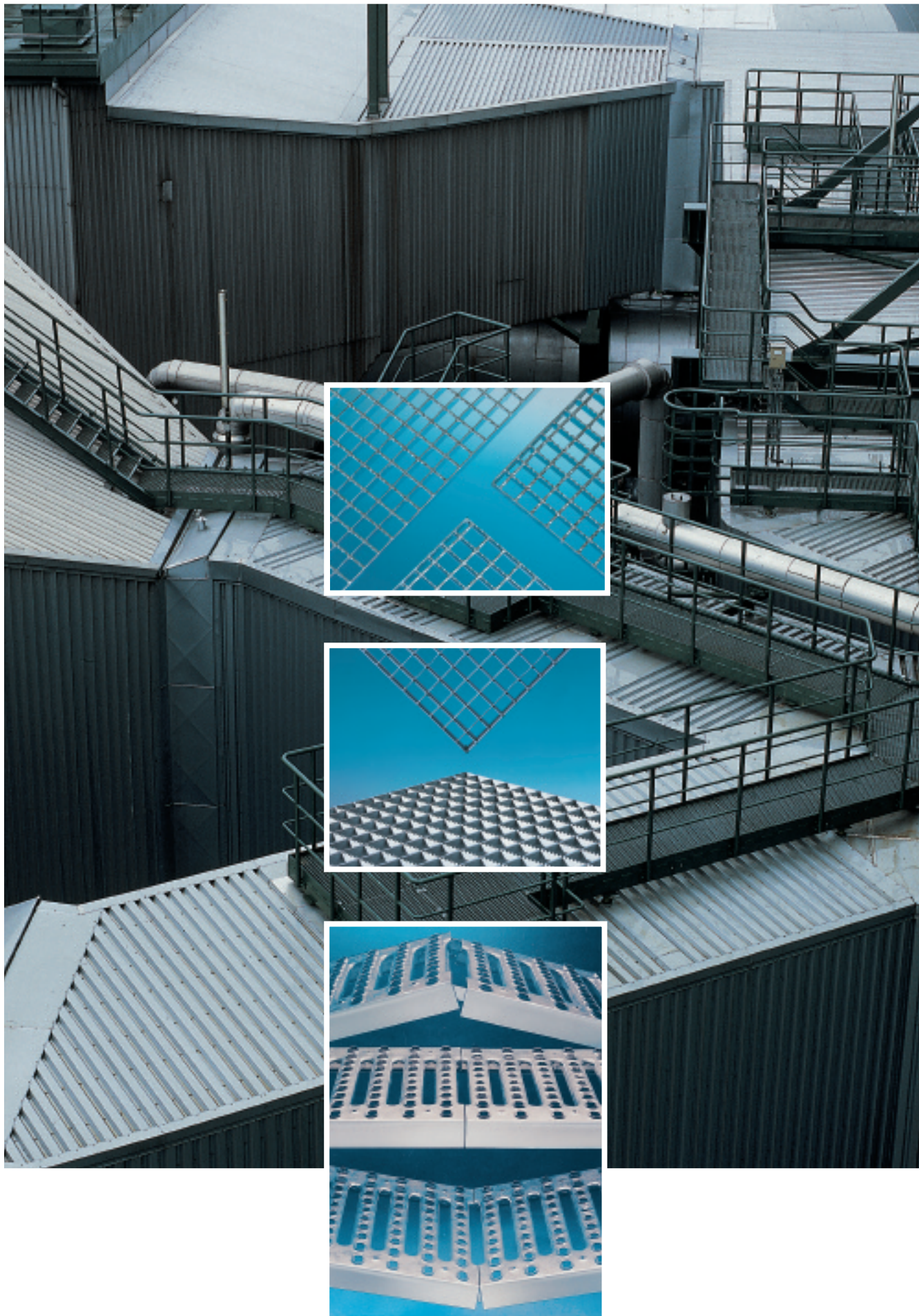

INDEX

The Company	4 - 5	
Quality	6 - 7	
Technical terms and services	8 - 10	→
Forge-welded gratings	11 - 20	
Load tables SP	16 - 17	
Standard gratings and stairtreads	18 - 19	
Pressure-locked gratings	21 - 31	→
Load tables P	26 - 27	
Load tables - heavy duty gratings	30 - 31	
Fixings for gratings	32 - 35	
Special gratings	36 - 38	
Perforated metal planks	39 - 64	
Load tables B	46 - 57	→
Fixings for perforated metal planks	60 - 61	
Special elements	62 - 64	
Spiral staircases	65 - 72	→
Serrated types	73 - 77	→
Surface treatment	78 - 81	→
Tolerances	82 - 85	→
Static calculation	86 - 91	→
Packaging / price information / Quotation and order form	92 - 97	→
Addresses	98 - 99	→



Lichtgitter - Head Office Stadtlonn

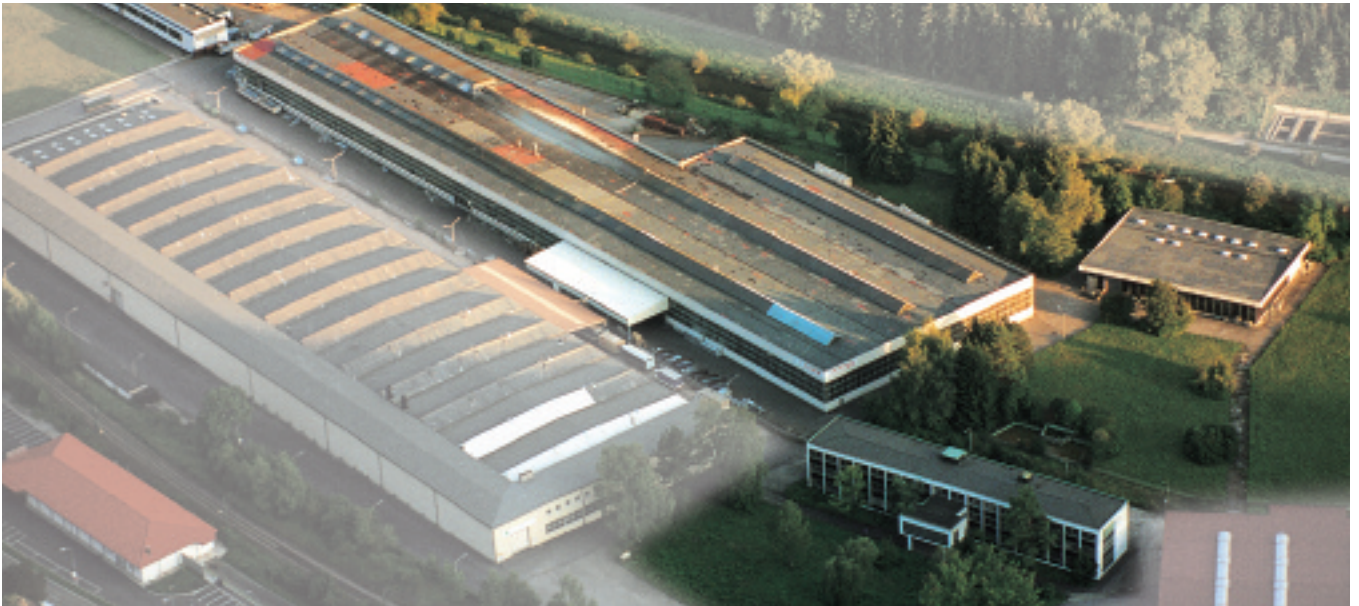

Lichtgitter - Works Sulz



Lichtgitter - Works Blumberg

The Company

Continuous performance and quality development as well as innovation in manufacturing techniques, in conjunction with a cautious and market driven entrepreneurial spirit of enterprise, have ensured Lichtgitter's place amongst the leading manufacturers of gratings and perforated metal planks worldwide.

The company of Lichtgitter was established in 1929 in order to carry out the specialized manufacturing of gratings. In the early days, production was concentrated on the manufacturing of welded gratings with honeycombed meshes. In 1956, the production of square-mesh interlocked gratings was added. In 1960/61, the production of pressure-locked gratings with square and rectangular meshes was grafted into the Lichtgitter production programme. In 1969, the production of forge-welded gratings followed. Also during this period, the production of welded gratings with honeycombed meshes and square-mesh interlocked gratings was terminated. In 1986, the already extensive production line was further extended by the inclusion of perforated metal planks, manufactured in Sulz a.N.

Production procedures and machines

(many protected by patent) were specially designed for the Lichtgitter production process. Gratings for normal and special loadings are produced with a high level of technical expertise.

The manufacturing processes cover gratings and perforated metal planks, fabricated from steel, stainless steel and aluminium. Some examples of their application include gratings for pedestrian or vehicle traffic, ceilings, sun protection, spiral staircases and so on. The production of special and custom-made gratings and perforated metal planks is a permanent and welcome challenge to our professional staff.

In addition to our eight production lines for pressure-locked gratings, we have six of the latest state of the art production lines for forge-welded gratings and four lines for perforated metal planks currently at our disposal.

Our workshops in Germany are located in Stadtlohn, Sulz and Casekow OT Blumberg. A number of galvanising plants also form part of the group.

To meet the demands of our international customers and to put into effect the

integration of the European and non-European grating markets, Lichtgitter has established joint ventures with partners, not only throughout Europe, but also worldwide.

This has formed the basis for the creation of a global network for both distribution and production outlets.

Lichtgitter therefore, has numerous subsidiaries and Service Centres within Europe at its disposal, in order to allow regular client communication and fulfil customer requirements in the most efficient and effective manner. This also allows us to offer short term deliveries as well as to provide access to competent technical support staff.

In the future, Lichtgitter will address its attention to the permanent improvement of its technical equipment, in order to identify new solutions in the areas of gratings and perforated metal planks.

Progress and innovation require high levels of foresight and responsibility. These are standards that Lichtgitter and its staff are fully committed to meeting and maintaining.



CERTIFICATE

The examination of the submitted documentation on quality management and the subsequent audit have established that the company



Lichtgitter Gesellschaft mbH
Siemensstraße, 48703 Stadtlohn / Germany

with its branches listed in the appendix to this certificate

for the following range of products:

**Manufacturing and Sales of Gratings,
Perforated Metal Planks, Stairs and Stairtreads
as well as hot dip galvanising of metal parts**

works in accordance with a
quality management system
which complies with
DIN EN ISO 9001:2000

MPA NRW report no.: 130001633
Registration no.: MPA NRW Q 033
Valid until: 16.12.2009
Duplicate

Dortmund, 17.12.2006



CMS-TGA-ZM-01-01-00

A. O. Krawinkel
Dipl.-Ing. Oskar Krawinkel
Manager of the quality management
system certification body

The appendix is an integral part of the certificate and comprises 1 page.
MPA NRW - Standort/Sitzstelle 186 - 50287 Dortmund - Tel: (+49) 231 1 00 00 0 - Fax: (+49) 231 1 00 00 01 - Internet: www.mpa-nrw.de



Appendix to the certificate with the registration No.: MPA NRW Q 033 of 17.12.2006; valid until 16.12.2009



Lichtgitter Gesellschaft mbH
Werk Sulz
Bahnhofstraße 76, 72172 Sulz / Germany

Lichtgitter Gesellschaft mbH
Werk Blumberg
Schönower Straße 6, 16306 Caselkow, OT Blumberg / Germany

Lichtgitter Gesellschaft mbH
Verzinkerei Stadtlohn
Siemensstraße, 48703 Stadtlohn / Germany

Verzinkerei Sulz GmbH
Bahnhofstraße 76, 72172 Sulz / Germany

Quality requires standards

Decades of experience in manufacturing of gratings are not always sufficient in itself. Only fully verified standards and properly followed instructions, along with further innovative development of production procedures and materials, can satisfy our client's demands and expectations, in respect of quality.

The results are:

- Quality during the production of forge-welded gratings, pressure-locked gratings, perforated metal planks, spiral staircases and associated fittings.
- Competence in solving problems.
- Successful completion of large projects.
- Manufacture of gratings and perforated metal planks in many variations.
- Surface treatment according to specific technical and architectural requirements.
- Order control by a fully integrated data processing system.
- An operational monitoring system for static inspections.
- Current quality control according to RAL-GZ 638 and RAL-GZ 639
- A Quality Management System according to DIN EN ISO 9001:2000.

This results in an impressive record of virtually zero product errors.

A decisive factor for many of our clients is the consistently reliable high quality of all of our products and services. In order to ensure the consistency of this quality, all relevant standards for gratings, perforated metal planks, stairs and stairtreads are to be strictly adhered to.

The manufacturing of our products is monitored and assessed in accordance with the following criteria:

- Quality Management System acc. to **DIN EN ISO 9001:2000** for the following range of products: manufacturing and sales of gratings, perforated metal planks, stairs and stairtreads as well as hot dip galvanising of metal parts.
- **BGI 588** Instruction sheet for gratings (Editor: Hauptverband der Gewerblichen Berufsgenossenschaft, Fachausschuss „Bauliche Einrichtungen“ der BGZ).
- **BGR 181** Instruction sheet for flooring in working areas with skid risk (for Editor see above).
- **RAL-GZ 638** Quality assurance for gratings (Editor: RAL Deutsches Institut für Gütesicherung und Kennzeichnung e.V.).
- **RAL-GZ 639** Quality assurance for perforated metal planks (for Editor see above).
- **DIN 24531-1** Gratings made of steel as tread covering, part I: gratings (Editor: Normenausschuss Maschinenbau [NAM] im DIN Deutsches

Institut für Normung e.V.)

- **DIN 24537-1** Gratings as floor coverings, part I: gratings (Editor see above)
- **DIN EN ISO 14122-1** Safety of machinery, permanent means of access to machines. Choice of fixed means of access between two levels.
- **DIN EN ISO 14122-2** Safety of machinery, permanent means of access to machines. Working platforms and walkways.
- **DIN EN ISO 14122-3** Safety of machinery, permanent means of access to machines. Stairs, stepladders and guardrails.
- **DIN EN ISO 1461** Galvanising of single parts (Editor: Normenausschuss Materialprüfung (NMP) im DIN Deutsches Institut für Normung e.V.)
- **AGI-Arbeitsblatt H 10** Gratings within industrial construction (Editor: Arbeitsgemeinschaft Industriebau e.V.).

We are an approved technical welding company acc. to DIN 18800-7 and are in possession of the welding certificate for rail vehicles and parts of them acc. to DIN 6700-2.

Lichtgitter is a member of the trademark association **Edelstahl Rostfrei** e.V.

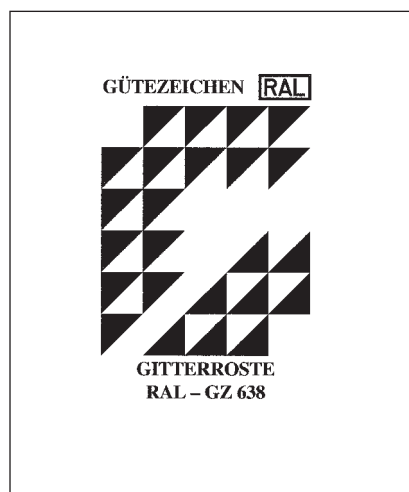

Technical Terms

Metal floors are grouped into two distinct categories, gratings (forge-welded and pressure-locked gratings) and perforated metal planks.

Gratings consist of a plurality of vertically aligned flat bearing bars, held upright, apart and parallel to each other at regular spacing, by a plurality of cross bars fixed transversely into them, also at regular spacing. The arrangement of bars as described would normally provide a free space area, in excess of 70% of the plan area.

All cut edges are bound with either binding bar, kick flat (toeplate), or in some instances, deep bar. Pressure-locked gratings are bound on all sides, whereas forge-welded gratings are normally only bound at the ends of the loadbearing bars.

Perforated metal planks are C-profiles formed from sheets with different formed patterns on their surfaces. These patterned profiles provide varying levels of serration on their top surfaces which in turn provides increased levels

of stability to the user. Gratings and perforated metal planks are light and easy to install. They are especially suitable for pedestrian and vehicle traffic on platforms, walkways, stairs, landings and stairtreads. They are lightweight, provide excellent light and air transmission, they have high strength and are easy to assemble and disassemble, whilst the serrated top surface ensures minimal collection of water and dust, i.e., all striking product advantages.

1. Bearing bars

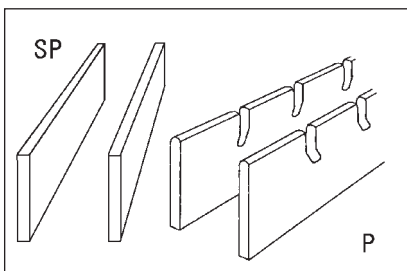

Bars bearing load lie parallel to each other between two grating supports

2. Cross bars

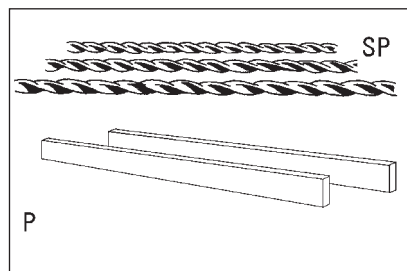

Connecting bars that are positioned transversely across bearing bars and are either welded or pressed into them at their intersection points to provide lateral restraint.

3. Binding

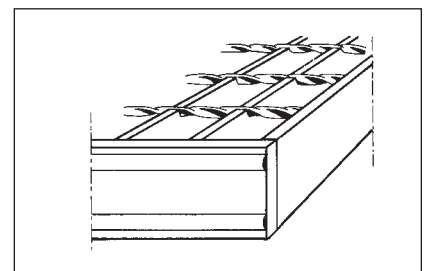

Bar or section to the edge of gratings, flush with the tops of bearing bars (in direction of bearing bar = binding along side; cross to bearing bar = cross binding).

4. Mesh

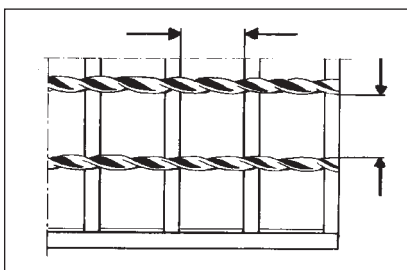

Clear distance between bearing bars and cross bars.

5. Pitch

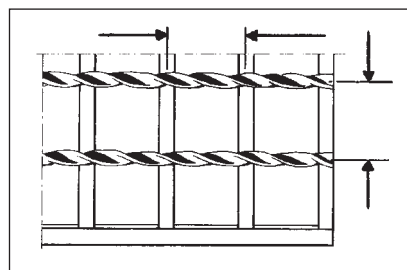

Distance between centre-to-centre of bearing bars and centre-to-centre of cross bars.

6. Perforated metal planks

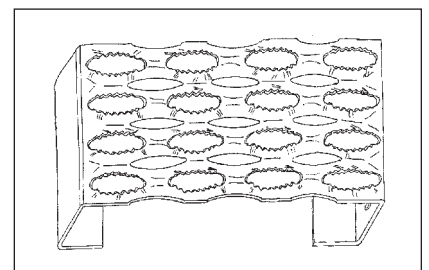

Perforated metal planks are produced by forming and perforating sheets. Depending on use, different patterns, widths and heights are possible.

7. Length (bearing bar direction)

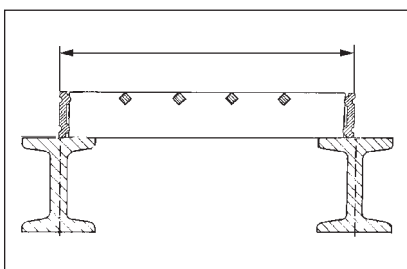

External distance of a metal grating in bearing bar direction. This size is termed length even if less than the width.

8. Width (cross bar direction)

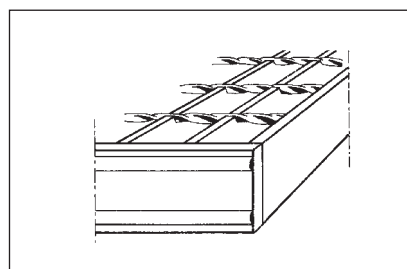

External distance of metal grating in cross bar direction. This size is termed width even if it is greater than the length.

9. Span (bearing bar direction)

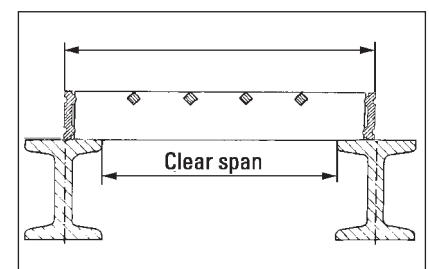

Distance between centre to centre of support. Clear span (effective span) is the clear distance between two supports.

10. Cutouts

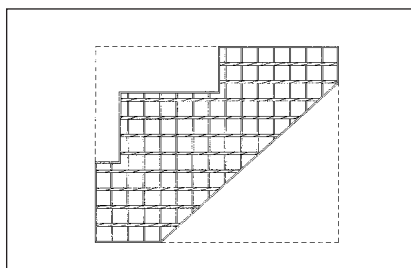

Straight or curved cutouts in metal gratings may be necessary to clear obstructions, plant or structural members. All cuts ends are bound after shaping.

11. Small cutouts

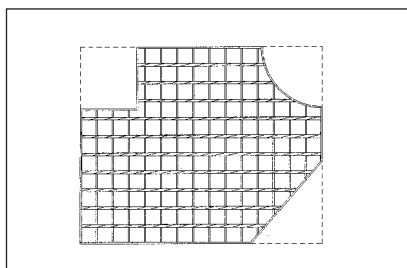

Straight or curved cutouts with a length of less than 0,5 m.

12. Kick flat (toe plate)

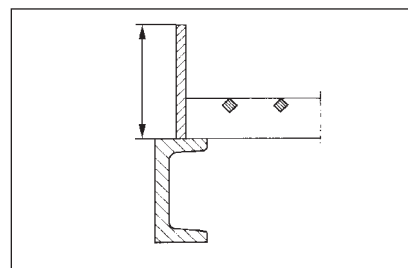

Binding bar projecting above the top surface of bearing bars by at least 100 mm (upstand).

13. Deep binding bar

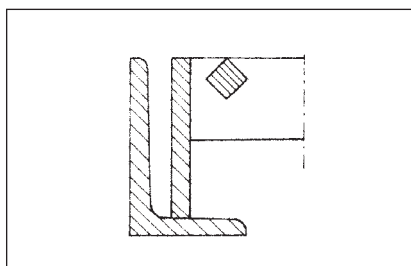

If an adjustment between height of grating and height of surrounding area is necessary, a deep binding bar is an option. Alternatively grating heights may be raised, by attaching other suitable sections to the underside.

14. Notch

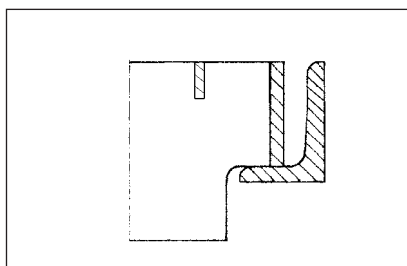

A cutout made to the lower part of bearing bars in order to reduce the level of the grating top to that of the surrounding area. A notched bearing bar should still be capable of sustaining the design load.

15. Substructure

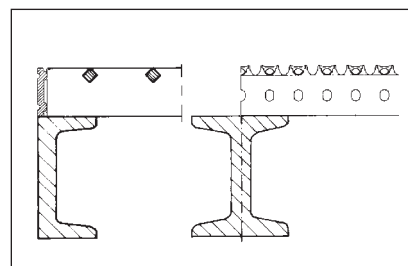

A structural unit provided beneath a grating that usually provides support.

16. Support

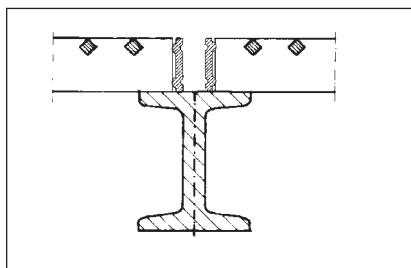

A structural section having a minimum clear distance of 30 mm available, to allow a minimum of 25 mm of bearing for bearing bars. Deviations may be permitted, providing suitable measures are taken to prevent excessive movement in the direction of bearing bars.

17. Side (end) plate

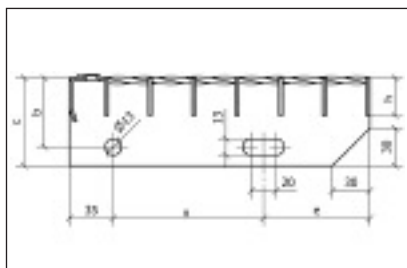

Plates provided with holes for bolting, welded to the ends of bearing bars in treads.

18. Perforated nosing

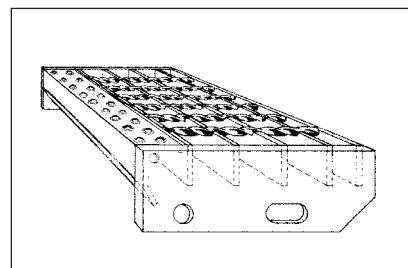

A visually accentuated member, perforated to provide serrations that reduce the risk of slip, which increases the load-carrying capability at its location and is welded to the leading edge of all treads and landings on stairs.

19. Serration

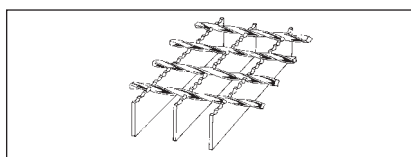

Forge-welded gratings are provided with a top surface that reduces the risk of slip in adverse conditions, by regular notching of bearing bars to produce serrations.

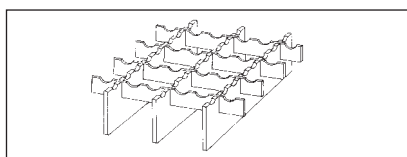

In order to increase the amount of serration and cover the transverse direction, pressure-locked gratings can also be supplied with serrated cross bars.

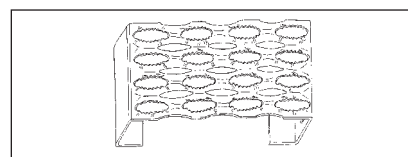

Perforated metal planks are provided with a serrated top surface by their perforations.

Service

To us „Service“ means

„Everything for the client“,

In other words, we continuously focus on our clients' requirements on every job and in all details.

Our working procedure includes:

- Acceptance and completion of enquiries and orders with professional and technical know-how.
- Competent, product and project related advice.
- Technical advisory services regarding calculation and determination of dimensions and fixings, choice of material and surface treatment.
- Fulfilment of quotations according to project related demands and valid standards and instructions.
- Static layout of gratings and perforated metal planks.
- Close co-operation with engineers and architects during realization of plans, e.g. regarding the use of gratings and perforated metal planks as construction elements.
- In special cases, taking measurements on site, subject to additional charges.
- Data transmission, in liaison with our technical department.
- Preparation of grating layout drawings by CAD, subject to costs and production requirements and based upon receipt of all relevant sketches, outline plans, construction drawings or CAD-drawings, in either DXF or DWG data format. (Data transmission is possible via diskette, E-mail or point to point connection via Modem or Fritzcard).
- Layout drawings available as a data set.
- Production planning and control through a complete integrated data processing system. All order settlement files are interconnected. In this way, the complete data is available from the time of enquiry to the time of delivery, including an automatic report of all operational data in our system. This optimisation virtually eliminates production faults.
- Co-operation with national and international trade-mark associations to determine standards and instructions.
- Permanent client information in respect of standards and their publications.





SP Forge-Welded Gratings

Permanent improvements in modern technology, partly protected by patent, in connection with decades of experience have assured Lichtgitter's place as the leading manufacturer of forge-welded gratings.

Production

Gratings are fully resistance welded, by creating heat at the metal intersection points of square twisted or round cross bars and solid bearing bars. As the forging temperature is reached, the cross bars are pressed into the bearing bars under high pressure and the materials are forge-welded together.

Stability

The resistance welding process, where heat is generated by an electric current, provides homogeneous welding at all intersection points and produces gratings of high stability, maximum strength and optimal load distribution.

Sectional stability

Special production features of forge-welded gratings provide incomparable product quality in terms of twisting and bending distortion. Even when additional cutouts have to be made (often unavoidable during erection), a high degree of stability is maintained.

End bar welding

Lichtgitter forge-welded gratings have special binding bars provided for the ends of bearing bars, complete with two stiffening corrugations shaped into them, which are supplied in the direction of the cross bars. During this production procedure developed by Lichtgitter, the bars are automatically welded to the ends of each bearing bar where they meet the corrugations. Scorification is completely avoided and the connection method aids free flowing of zinc at the ends of bearing bars during the hot dip galvanising process. The final result is a forge-welded grating with a continuous high quality and clear unblemished binding at panel ends. A flat bar is used to provide binding on sides of gratings supplied in the direction of bearing bars. Heavy-duty gratings are provided with flat binding bars on all sides.

Protection against corrosion

The finished forge-welded gratings are galvanised according to DIN EN ISO 1461. The zinc coating ensures excellent protection against corrosion (see surface treatment pages 78-81). In special cases, additional protection can be achieved by bitumen dipping, dip or spray painting, plastic coating or other surface treatments (preferably after galvanising).

Safety

Cross bars fitted flush with the top of bearing bars gives a secure foothold, which contributes to a higher level of safety and helps to minimise accidents.

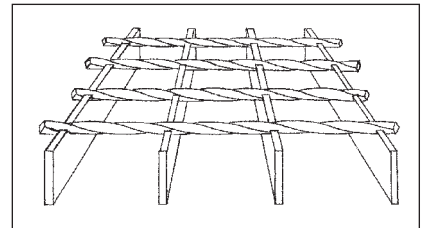
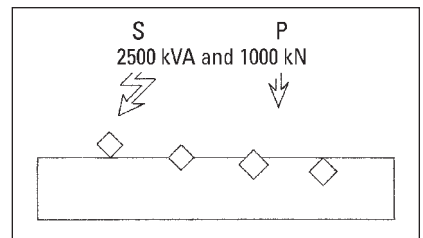
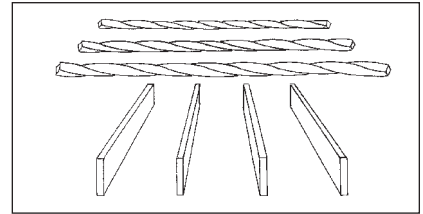

Principle of construction



Standard Programme

Forge-welded gratings are normally pre-fabricated in bearing bar lengths of 3050 mm, 6100 mm and 12200 mm. These panels can be easily transported and further processed at low-costs. If forge-welded gratings are galvanised, the maximum dimensions should not exceed 3050 x 1000 mm. Depending on bearing bar thickness, twisted cross bars with different cross sections are used.

Fabrication widths

The process of manufacturing forge-welded gratings produces a 1000 mm (nominal size) standard width. Shrinkage following the welding procedure, results in an actual width of approximately 998 mm, thereby providing additional erection clearance. Standard widths are 485 mm and 1000 mm.

Dimensions deviating from 1000 mm are subject to additional manufacturing requirements and produce scrap. It is thereby recommended that forge-welded gratings should not have dimensions deviating from standard production dimensions. The minimum dimension of single gratings within walkways and platforms is 279 mm (see fabrication widths).

Types of forge-welded gratings

By means of type designation, fabrication methods (forge-welded gratings), bearing bar dimension, pitch (see sketch) and binding bar are fixed. Serrated gratings are indicated by an „X“ before type designation (e.g. XSP 330-34/38-3)

Special types

In addition to standard designs, further pitches and materials are possible on demand.

Layout example

The example considers standard widths with a make-up panel, whereby the make-up panel width should be taken from the nearest fabrication width available. The erection clearance (approx. 3 mm) of single gratings is considered during the fabrication.



Fabrication widths SP-gratings at bearing bar thickness 3 mm					
Pitch of bearing bars 34,33 mm; panel width = nominal size 1000 mm					
Number of bars	grating width	number of bars	grating width	number of bars	grating width
2	39 mm	12	382 mm	22	726 mm
3	73 mm	13	417 mm	23	760 mm
4	108 mm	14	451 mm	24	794 mm
5	142 mm	15	485 mm	25	829 mm
6	176 mm	16	520 mm	26	863 mm
7	211 mm	17	554 mm	27	897 mm
8	245 mm	18	588 mm	28	932 mm
9	279 mm	19	623 mm	29	966 mm
10	314 mm	20	657 mm	30	1000 mm
11	348 mm	21	691 mm		

All mentioned dimensions are theoretical and include normal production tolerances (see page 82/83).

Types of forge-welded gratings	
Example SP 330 - 34/38 - 3	
Forge-welded gratings	SP
Bearing bar \varnothing 30 x 3 mm	330
Pitches 34 x 38 mm	-34/38
Banding \varnothing 30 x 3 mm	-3
Type	SP 330 - 34/38 - 3
Type as above, but	
Pitch 34 x 50 mm	-34/50
Type	SP 330 - 34/50 - 3

Serrated type N° 1 and 11 (see page 15).

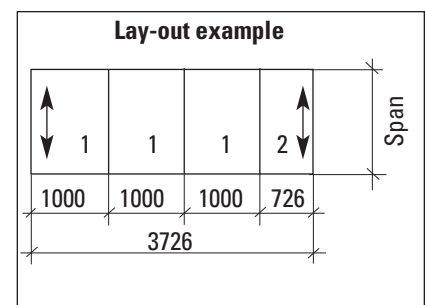
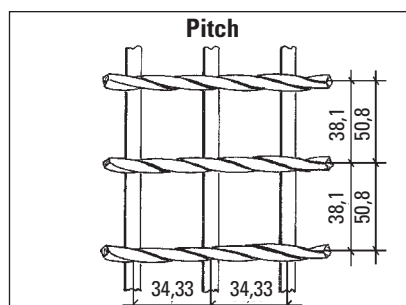

SP Forge-Welded Gratings

Forge-welded gratings are especially designed for platforms, landings and walkways in power stations and all kinds of industrial applications. Their particular features include, an excellent loadbearing capacity coupled with torsional rigidity.

Furthermore, forge-welded gratings are particularly suited to heavy-duty gratings. The homogeneous welding between bearing and cross bar permits them to withstand shearing forces without problems. Sizes are obtained by considering static and dynamic loading along with the required free span.

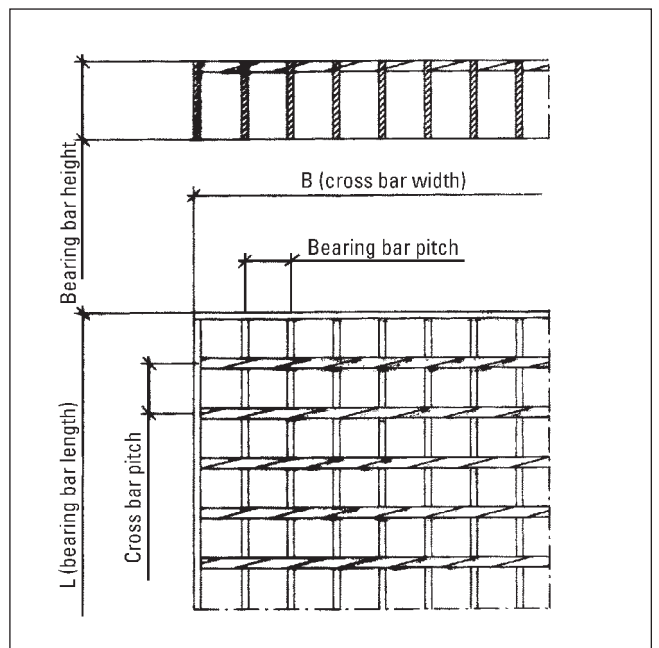
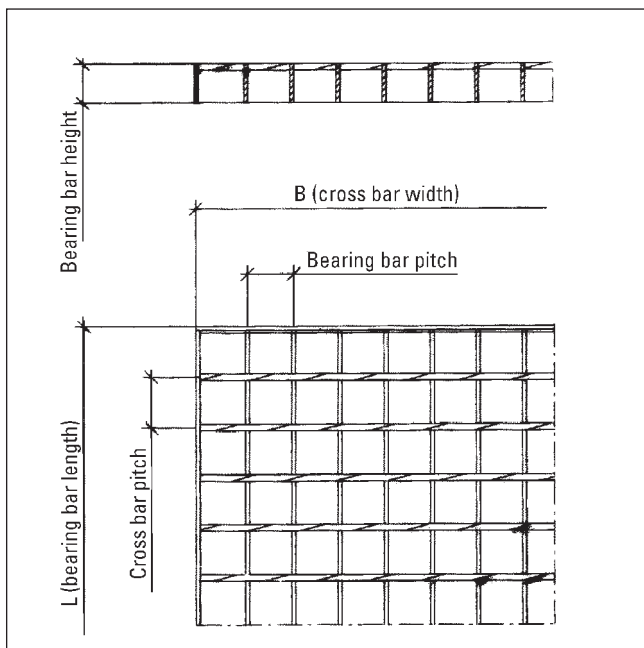
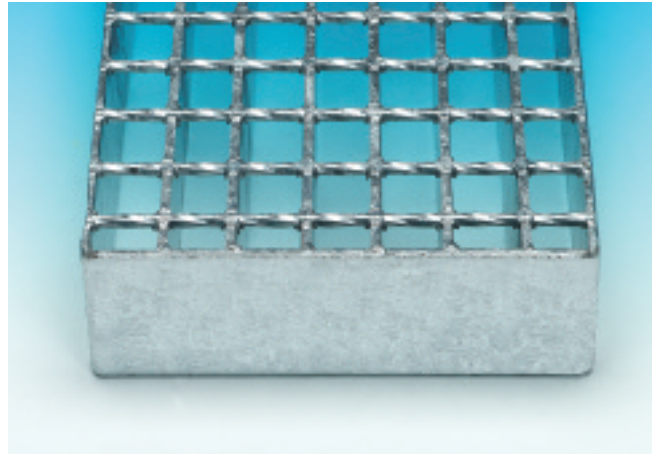
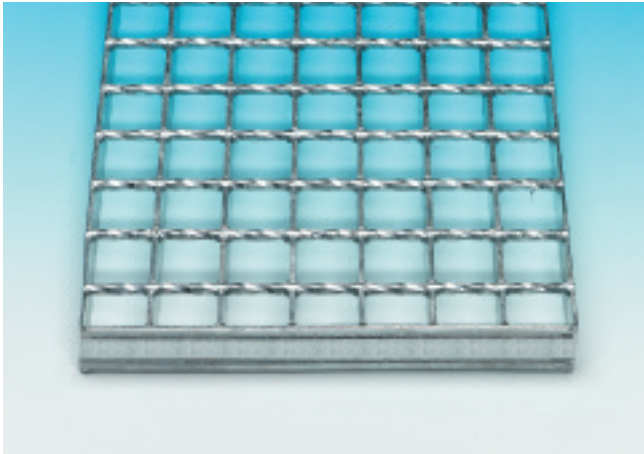

Forge-welded gratings SP Standard		
Bearings bars	Pitches	
	Bearing bar pitch	Cross bar pitch
25 x 2 mm	34,33 mm	38,1 mm
30 x 2 mm		50,8 mm
40 x 2 mm		
25 x 3 mm		
30 x 3 mm		
40 x 3 mm		
Material Surface		S 235 JR (≙ St 37-2) see pages 76 / 77

Forge-welded gratings SP Heavy-duty gratings		
Bearing bars	Pitches	
	Bearing bar pitch	Cross bar pitch
30 x 4 mm	34,33 mm	38,1 mm
40 x 4 mm		
30 x 5 mm		
40 x 5 mm		
50 x 5 mm		
60 x 5 mm		
70 x 5 mm		
80 x 5 mm		
Material Surface		

SP Forge-Welded Gratings

Forge welded gratings with serrated bars are used in dirt intensified areas of high pollution and slippery surfaces. They are inspected in accordance with instruction sheet „BGI 181“ of the „Berufsgenossenschaft“ professional association. Serrations are achieved by punching the top surface of bearing bars. Serrated gratings are indicated by an „X“ before type designation (see page 72 to 75).

Forge-welded gratings with the particular bearing bar and cross bar pitches shown below (special gratings) are necessary for example, when small objects need to be prevented from falling through the grating. Smaller gaps between bars, can also be achieved by welding suitable continuous round bars to the underside of the cross bars, in the bearing bar direction and between each bearing bar (offshore-gratings for specific offshore projects). A minimum quantity of 300 m² is required for special gratings.

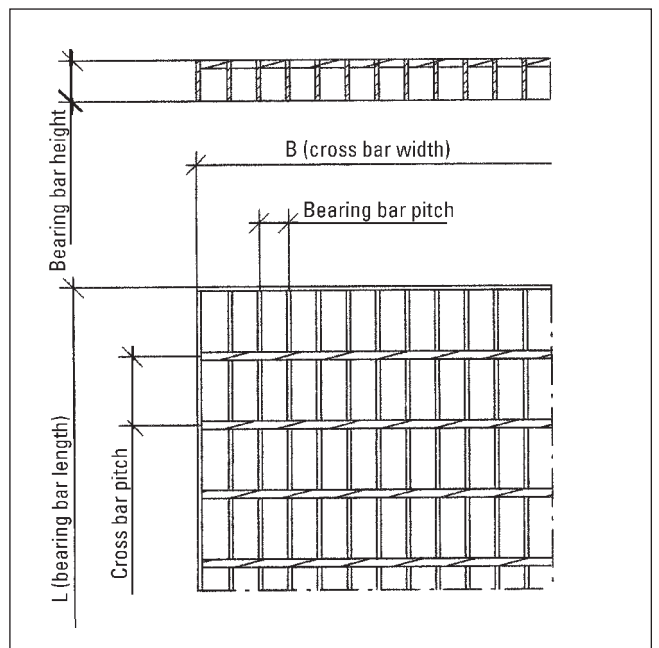
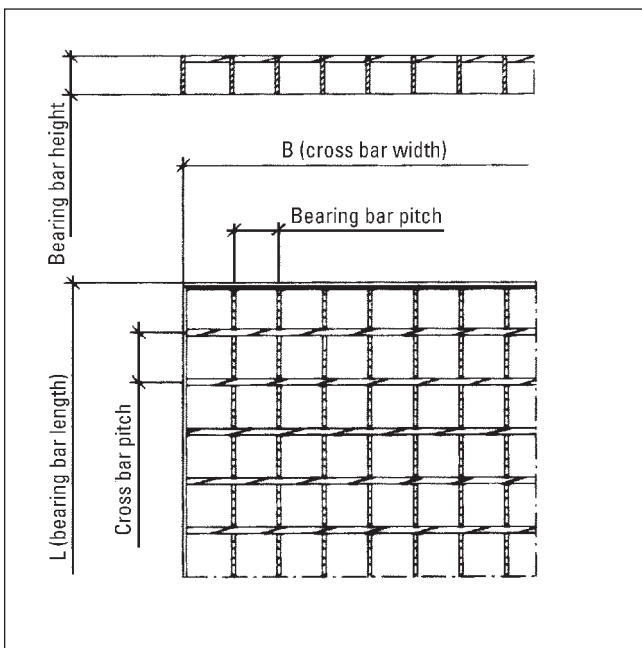
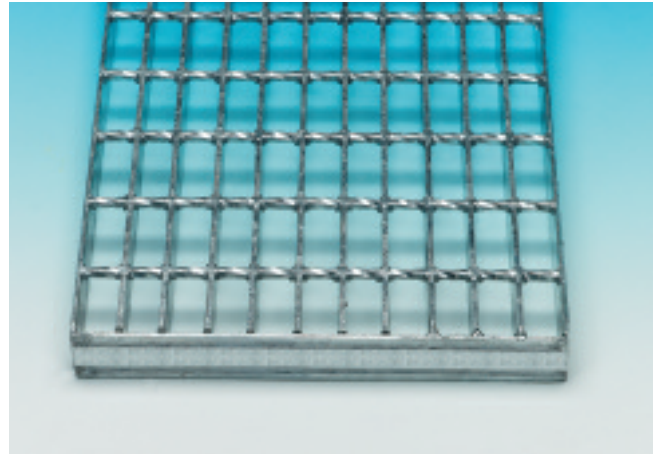
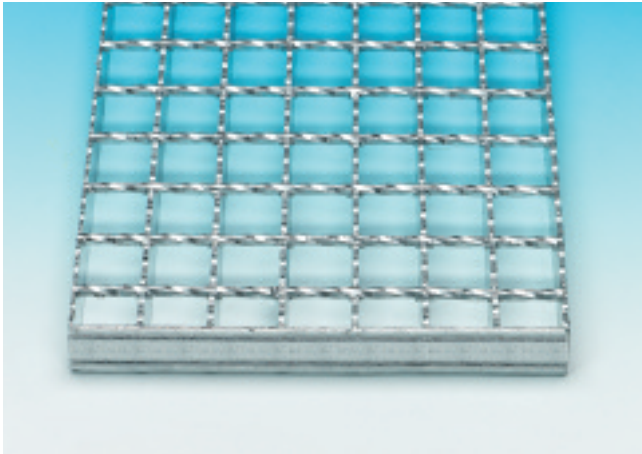

Forge-welded gratings XSP Serrated type no. 1 & no. 11			
Bearing bars	XSP n°	Pitches	
		Bearing bar pitch	Cross bar pitch
25 x 2 mm	1	34,33 mm	38,1 mm
30 x 2 mm	1		
40 x 2 mm	1		
30 x 3 mm	1		
40 x 3 mm	1		
40 x 4 mm	1		
30 x 2 mm	11		
30 x 3 mm	11		
40 x 3 mm	11		
30 x 4 mm	1	34,33 mm	50,8 mm
Material Surface	S 235 JR (≙ St 37-2) see pages 76 / 77		

Forge-welded gratings as SP Special gratings		
Bearing bars	Pitches	
	Bearing bar pitch	Cross bar pitch
25 x 2 mm	16,60 mm	24,0 mm
30 x 2 mm	21,64 mm	33,0 mm
40 x 2 mm	30,16 mm	38,1 mm
25 x 3 mm	33,17 mm	50,8 mm
30 x 3 mm	41,46 mm	76,2 mm
40 x 3 mm	45,30 mm	101,6 mm
Material Surface	S 235 JR (≙ St 37-2) see pages 76 / 77	
	Offshore-gratings on request	

SP Load table for Forge-Welded Gratings

grating type	bearing bar	pitch kg/qm	approx. galv weight *	Clear span in mm										
				500	600	700	800	900	1000	1100	1200	1300	1400	
SP 225-34/38-3	25 x 2 mm	34x38 mm	18,7	Fv	31,05	21,6	15,85	12,15	9,6	7,75	6,4	5,4		
				f	0,16	0,23	0,31	0,41	0,51	0,63	0,77	0,91		
				Fp	2,65	2,15	1,80	1,50	1,35	1,20	1,05	1,00		
				f1	0,15	0,21	0,28	0,36	0,45	0,55	0,67	0,78		
SP 230-34/38-3	30 x 2 mm	34x38 mm	21,5	Fv	44,75	31,10	22,85	17,50	13,8	11,20	9,25	7,75	6,60	5,70
				f	0,13	0,19	0,26	0,34	0,43	0,53	0,64	0,76	0,89	1,04
				Fp	3,80	3,05	2,55	2,20	1,90	1,70	1,50	1,40	1,30	1,20
				f1	0,12	0,17	0,23	0,30	0,38	0,46	0,55	0,66	0,76	0,88
SP 240-34/38-3	40 x 2 mm	34x38 mm	27,2	Fv	79,55	55,20	40,60	31,10	24,55	19,90	16,45	13,80	11,80	10,15
				f	0,10	0,14	0,19	0,25	0,32	0,40	0,48	0,57	0,67	0,78
				Fp	6,70	5,35	4,45	3,80	3,35	2,95	2,65	2,40	2,25	2,05
				f1	0,09	0,13	0,17	0,23	0,28	0,35	0,42	0,49	0,58	0,66
SP 325-34/38-3	25 x 3 mm	34x38 mm	24,5	Fv	46,60	32,40	23,80	18,20	14,40	11,65	9,60	8,10	6,90	5,95
				f	0,16	0,23	0,31	0,41	0,51	0,64	0,77	0,91	1,07	1,24
				Fp	4,00	3,20	2,65	2,30	2,00	1,80	1,60	1,45	1,35	1,25
				f1	0,15	0,21	0,28	0,36	0,45	0,55	0,67	0,79	0,92	1,06
SP 330-34/38-3	30 x 3 mm	34x38 mm	28,5	Fv	67,10	46,60	34,25	26,2	20,70	16,80	13,90	11,65	9,90	8,55
				f	0,13	0,19	0,26	0,34	0,43	0,53	0,64	0,76	0,89	1,04
				Fp	5,70	4,60	3,80	3,30	2,85	2,55	2,30	2,10	1,90	1,75
				f1	0,12	0,17	0,23	0,30	0,38	0,46	0,55	0,66	0,77	0,89
SP 340-34/38-3	40 x 3 mm	34x38 mm	36,5	Fv	119,30	82,85	60,90	46,60	36,80	29,80	24,65	20,7	17,65	15,20
				f	0,10	0,14	0,19	0,25	0,32	0,40	0,48	0,57	0,67	0,78
				Fp	10,00	8,00	6,70	5,70	5,00	4,45	4,00	3,65	3,35	3,10
				f1	0,09	0,13	0,17	0,23	0,28	0,35	0,42	0,49	0,58	0,66
SP 440-34/38-4	40 x 4 mm	34x38 mm	47,0	Fv	159,10	110,50	81,20	62,15	49,10	39,75	32,90	27,60	23,55	20,30
				f	0,10	0,14	0,19	0,25	0,32	0,40	0,48	0,57	0,67	0,78
				Fp	13,35	10,70	8,90	7,65	6,70	5,95	5,35	4,85	4,45	4,10
				f1	0,09	0,13	0,18	0,23	0,28	0,35	0,42	0,49	0,58	0,66
SP 530-34/38-5	30 x 5 mm	34x38 mm	46,1	Fv	111,85	77,65	57,05	43,70	34,50	27,95	23,10	19,40	16,55	14,25
				f	0,13	0,19	0,26	0,34	0,43	0,53	0,64	0,76	0,89	1,04
				Fp	9,55	7,65	6,35	5,45	4,80	4,25	3,80	3,50	3,20	2,95
				f1	0,12	0,17	0,23	0,30	0,38	0,46	0,55	0,66	0,77	0,88
SP 540-34/38-5	40 x 5 mm	34x38 mm	59,4	Fv	198,85	138,10	101,45	77,65	61,40	49,70	41,10	34,50	29,40	25,35
				f	0,10	0,14	0,19	0,25	0,32	0,40	0,48	0,57	0,67	0,78
				Fp	16,70	13,35	11,15	9,55	8,35	7,40	6,70	6,10	5,55	5,15
				f1	0,09	0,13	0,17	0,23	0,28	0,35	0,42	0,49	0,57	0,66
SP 550-34/38-5	50 x 5 mm	34x38 mm	72,7	Fv	310,70	215,80	158,50	121,40	95,90	77,70	64,20	53,95	45,95	39,60
				f	0,08	0,11	0,15	0,20	0,26	0,32	0,38	0,46	0,54	0,62
				Fp	25,70	20,55	17,10	14,70	12,85	11,40	10,30	9,35	8,55	7,90
				f1	0,07	0,10	0,14	0,18	0,23	0,28	0,33	0,39	0,46	0,53
SP 560-34/38-5	60 x 5 mm	34x38 mm	86,0	Fv	447,40	310,70	228,30	174,8	138,10	111,85	92,45	77,70	66,20	57,05
				f	0,07	0,10	0,13	0,17	0,21	0,26	0,32	0,38	0,45	0,52
				Fp	36,35	29,10	24,25	20,80	18,20	16,15	14,55	13,20	12,10	11,20
				f1	0,06	0,09	0,12	0,15	0,19	0,23	0,28	0,33	0,38	0,44
SP 570-34/38-5	70 x 5 mm	34x38 mm	99,3	Fv	609,00	422,90	310,70	237,90	187,95	152,25	125,80	105,75	90,10	77,70
				f	0,06	0,08	0,11	0,14	0,18	0,23	0,27	0,33	0,38	0,44
				Fp	48,70	38,95	32,50	27,85	24,35	21,65	19,50	17,70	16,25	15,00
				f1	0,05	0,07	0,10	0,13	0,16	0,20	0,24	0,28	0,33	0,38
SP 580-34/38-5	80 x 5 mm	34x38 mm	112,5	Fv	795,40	552,40	405,85	310,70	245,50	198,85	164,35	138,10	117,70	101,45
				f	0,05	0,07	0,10	0,13	0,16	0,20	0,24	0,29	0,34	0,39
				Fp	62,50	50,00	41,70	35,70	31,25	27,80	25,00	22,75	20,85	19,25
				f1	0,05	0,07	0,09	0,11	0,14	0,17	0,21	0,25	0,29	0,33

* Key to symbols

F_v = uniformly distributed load (UDL) in kN/m²
 f = deflection in cm at load F_v

F_p = concentrated load in kN uniformly distributed over an area of 200 x 200 mm
 f_1 = deflection values in cm at load F_p

1 kN = 1000 N = approx. 100 kg

Clear span in mm										
1500	1600	1700	1800	1900	2000	2100	2200	2300	2400	2500
5,00										
1,19										
1,10										
1,01										
8,85	7,75	6,90	6,15	5,50	5,00					
0,89	1,02	1,15	1,29	1,43	1,59					
1,90	1,80	1,65	1,60	1,50	1,40					
0,76	0,86	0,96	1,08	1,20	1,33					
5,20										
1,43										
1,15										
1,21										
7,45	6,55	5,80	5,20							
1,19	1,35	1,53	1,71							
1,65	1,50	1,45	1,35							
1,01	1,15	1,29	1,44							
13,25	11,65	10,30	9,20	8,25	7,45	6,75	6,15	5,65	5,20	
0,89	1,02	1,15	1,29	1,43	1,59	1,75	1,92	2,10	2,29	
2,90	2,70	2,50	2,35	2,20	2,10	2,00	1,90	1,80	1,70	
0,76	0,86	0,97	1,08	1,20	1,33	1,46	1,60	1,75	1,90	
17,70	15,55	13,75	12,30	11,00	9,95	9,00	8,20	7,50	6,90	6,35
0,89	1,02	1,15	1,29	1,43	1,59	1,75	1,92	2,00	2,29	2,48
3,80	3,55	3,35	3,15	2,95	2,80	2,65	2,55	2,40	2,30	2,25
0,76	0,86	0,97	1,08	1,20	1,33	1,46	1,60	1,75	1,90	2,06
12,40	10,90	9,70	8,65	7,75	7,00	6,35	5,80	5,30		
1,19	1,35	1,53	1,71	1,91	2,12	2,33	2,56	2,80		
2,70	2,55	2,40	2,25	2,10	2,00	1,90	1,80	1,75		
1,01	1,15	1,29	1,44	1,60	1,77	1,95	2,14	2,33		
22,10	19,40	17,20	15,35	13,80	12,40	11,30	10,30	9,40	8,65	7,95
0,89	1,02	1,15	1,29	1,43	1,59	1,75	1,92	2,10	2,29	2,48
4,75	4,45	4,20	3,95	3,70	3,50	3,35	3,20	3,05	2,90	2,80
0,76	0,86	0,97	1,08	1,20	1,33	1,46	1,60	1,75	1,90	2,06
34,50	30,35	26,90	24,00	21,50	19,40	17,60	16,05	14,70	13,50	12,40
0,71	0,81	0,92	1,03	1,15	1,27	1,40	1,54	1,68	1,83	1,98
7,35	6,85	6,40	6,05	5,70	5,40	5,15	4,90	4,70	4,45	4,30
0,61	0,69	0,78	0,87	0,96	1,06	1,17	1,28	1,40	1,52	1,65
49,70	43,70	38,70	34,50	31,00	27,95	25,35	23,10	21,15	19,40	17,90
0,60	0,68	0,77	0,86	0,96	1,06	1,17	1,28	1,40	1,52	1,65
10,40	9,70	9,10	8,55	8,10	7,65	7,30	6,90	6,60	6,30	6,05
0,51	0,57	0,65	0,72	0,80	0,89	0,98	1,07	1,17	1,27	1,37
67,65	59,45	52,70	47,00	42,15	38,05	35,40	31,45	28,80	26,45	24,35
0,51	0,58	0,66	0,73	0,82	0,91	1,00	1,10	1,20	1,31	1,42
13,90	13,00	12,20	11,45	10,80	10,25	9,75	9,30	8,85	8,50	8,10
0,43	0,49	0,55	0,62	0,69	0,76	0,84	0,92	1,00	1,09	1,18
88,40	77,70	68,80	61,40	55,10	49,70	45,10	41,10	37,60	34,50	31,80
0,45	0,51	0,57	0,64	0,72	0,79	0,88	0,96	1,05	1,14	1,24
17,85	1,65	15,60	14,70	13,90	13,15	12,50	11,90	11,35	10,90	10,40
0,38	0,43	0,48	0,54	0,60	0,67	0,73	0,80	0,87	0,95	1,03

Data

Material stress (permissible tension):
16 kN/cm² (material S235JR ± St 37-2)

Safety factor to yield point: 1,5

Safety factor to breaking limit: 2,05

The **grating support** should provide a bearing distance at each end of at least 25 mm. Deviations may be permitted, providing suitable measures are taken to prevent excessive movement in the direction of bearing bars (see instruction sheet BGI 588).

Pedestrian traffic

Yellow: Gratings manufactured in accordance with the requirements of instruction sheet BGI 588 of the Berufsgenossenschaft professional association and to quality instructions RAL-GZ 638, are considered suitable for pedestrian traffic when they meet the following design criteria:

The maximum permissible deflection 'f', does not exceed 1/200th of the span 'L' or 4 mm whichever is the lesser, under a concentrated load of 1,5 kN applied in the most unfavourable position, over a concentrated load area of 200 x 200 mm.

Green: The maximum permissible deflection 'f', does not exceed 1/200th of the span 'L', under a concentrated load of 1,5 kN applied in the most unfavourable position, over a concentrated load area of 200 x 200 mm.

Blue: The maximum permissible deflection 'f', does not exceed 1/200th of the span 'L', under a uniformly distributed load of 5 kN/m².

The multiplication factor for gratings with a pitch of approx. 34 x 50 mm is 0,95.

Example: SP 330-34/50-3
Clear span 1100 mm
load according to table
13,90 kN x 0,95 = 13,20 kN/m².

SP Standard Gratings

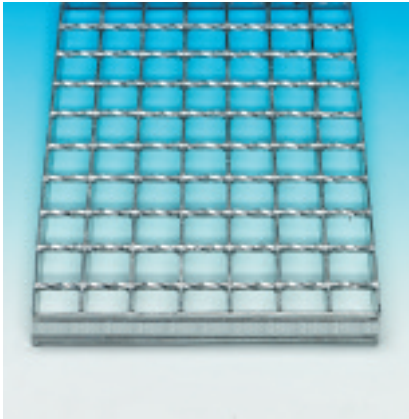

All standard gratings can be delivered ex stock. Underlined dimensions are bearing bar dimensions.
Grating dimensions / tolerances in length and width: + 0 mm / - 4 mm acc. RAL-GZ 638.
Load values of continuously distributed load in kN/m² (see pages 16/17).

Standard forge-welded gratings				
Type	Bearing bar	Nominal mesh	Dimension	Weight kg/piece
SP 230 - 34/38 - 3	30 x 2 mm	ca. 30 x 30 mm	<u>500</u> x 1000 mm	11,3
			<u>600</u> x 1000 mm	13,5
			<u>700</u> x 1000 mm	15,5
			<u>800</u> x 1000 mm	17,4
			<u>900</u> x 1000 mm	19,5
			<u>1000</u> x 1000 mm	21,6
			<u>1100</u> x 1000 mm	23,5
			<u>1200</u> x 1000 mm	25,6
SP 330 - 34/38 - 3	30 x 3 mm	ca. 30 x 30 mm	<u>250</u> x 1000 mm	8,0
			<u>500</u> x 1000 mm	14,8
			<u>600</u> x 1000 mm	17,7
			<u>700</u> x 1000 mm	20,4
			<u>800</u> x 1000 mm	23,0
			<u>900</u> x 1000 mm	25,8
			<u>1000</u> x 1000 mm	28,5
			<u>1100</u> x 1000 mm	31,2
<u>1200</u> x 1000 mm	34,0			

SP Panels

Forge-welded panels self coloured, without binding in direction of cross bars					
plain			serrated		
Type	Dimension	kg/piece	Type	Dimension	kg/piece
SP 225-34/38-3	6100 x 1000 mm	101,5	XSP 230-34/38-3 (1)	<u>6100</u> x 1000 mm	115,0
SP 230-34/38-3	6100 x 1000 mm	116,5	XSP 330-34/38-3 (1+11)	<u>6100</u> x 1000 mm	154,0
SP 240-34/38-3	6100 x 1000 mm	146,0	XSP 340-34/38-3 (1+11)	<u>6100</u> x 1000 mm	198,0
SP 330-34/38-3	6100 x 1000 mm	156,7	serration no. 1 = serration class R10		
SP 340-34/38-3	6100 x 1000 mm	200,0	serration no. 11 = serration class R11		
SP 440-34/38-4	6100 x 1000 mm	258,0			

SP Standard Stairtreads

Requirements for steel stairs (Extract from DIN EN 14122-3)

The rise, 'h' and going 'g', shall meet the formula, $600 \leq g + 2h \leq 660$. The overlap, 'r' of step or landing shall be ≥ 10 mm. The length of landing 'l' shall be at least 800 mm and in any case \geq the width of the stair, 'w'.
On the same flight, the rise shall be constant wherever possible. In the case where it is not possible to maintain the height of the rise between the level of departure and the lower step, it may be reduced by a maximum of 15%.
Steps shall resist the following unfactored loadings:
If the width 'w' < 1200 mm, then 1,5 kN shall be distributed over an area of 100 x 100 mm where one boundary is the leading edge of the nosing, applied at the middle of the stair width. If the width 'w' \geq 1200 mm, then respectively 1,5 kN shall be distributed simultaneously over each of the 100 x 100 mm areas applied at the most unfavourable points, spaced at intervals of 600 mm, where one boundary is the leading edge of the nosing. The deflection of the supporting structure and the stairs does not exceed under load 1/300 of the span, maximum 6,0 mm.

- | | | | |
|---|-------------------|----------|----------------|
| H | Climbing height | r | Overlap |
| g | Going | α | Angle of pitch |
| e | Headroom | w | Width |
| h | Rise | p | Pitch line |
| l | Length of landing | t | Height of step |
| | | c | Clearance |

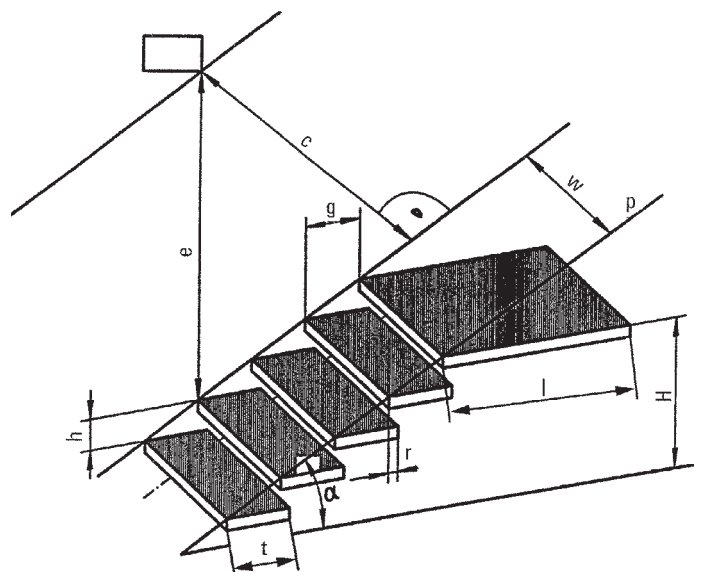

Production

Forge-welded gratings produced for stairtreads are produced in the same types as used for platforms and walkways. They are **always** supplied with serrated, perforated nosing and welded side plates.

All stairtreads are inert gas welded, in special jigs.

Installation

The stairtreads in accordance to DIN can be produced regarding the length with a minus tolerance and furthermore the stair construction can have tolerances. So it may be necessary to verify before screwing the treads if a washer between cheek and stairtread is needed. Thereby possible damages of the welding of the bearing bars to the side plates can be avoided.

Long hole type

For easy fitting to stair stringers, each side plate is always sup-

plied with one round and one slotted fixing hole.

Perforated nosing increases the anti-slip value of the stairtreads and favourably accentuates the leading edge visually. This is an important contribution to safety.

We reserve the right to supply stairtreads with bearing bars thicker and higher than ordered, at no extra charge. **We can offer other types and sizes of stairtreads with perforated nosing, depending on demand.**

On request, we supply fixings for stairtreads consisting of:
 Hexagonal bolts M 12 x 35 ISO 4016 (DIN 601)
 Hexagonal nuts M 12 ISO 4032 (DIN 934)
 Washers A 14 DIN 7989.

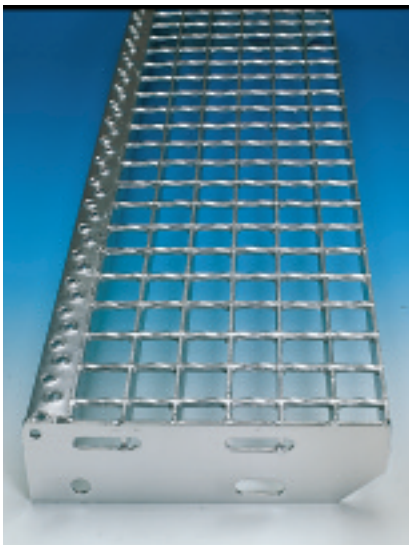

Standard stairtreads acc. to DIN 24531-1 (preferred sizes)							
Type	Bearing bar	Dimension	b	c	d	e	kg/tread
SP 330-34/38-3 Nominal mesh approx. 30x30 mm	30 x 3 mm	600 x 240 mm	55	70	120	85	5,2
		600 x 270 mm	55	70	150	85	5,8
		800 x 240 mm	55	70	120	85	6,6
		800 x 270 mm	55	70	150	85	7,5
		800 x 305 mm	55	70	180	90	8,3
		1000 x 240 mm	55	70	120	85	8,2
SP 340-34/38-3 Nominal mesh approx. 30x30mm	40 x 3 mm	800 x 240 mm	55	70	120	85	8,0
		800 x 270 mm	55	70	150	85	9,0
		1000 x 240 mm	55	70	120	85	10,0
		1000 x 270 mm	55	70	150	85	11,0
		1200 x 240 mm	55	70	120	85	11,7
		1200 x 270 mm	55	70	150	85	13,2
		1200 x 305 mm	55	70	180	90	14,7

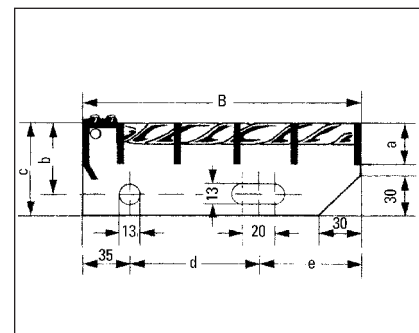

Other stairtreads ex stock							
Type	Bearing bar	Dimension	b	c	d	e	kg/tread
SP 225-34/38-3 Nominal mesh approx. 30x30 mm	25 x 2 mm	600 x 185 mm	55	70	90	60	3,0
		700 x 185 mm	55	70	90	60	3,4
SP 230-34/38-3 Nominal mesh approx. 30x30 mm	30 x 2 mm	600 x 205 mm	55	70	90	80	3,6
		600 x 240 mm	55	70	120	85	4,2
		600 x 270 mm	55	70	150	85	4,6
		700 x 220 mm	55	70	100	85	4,3
		800 x 220 mm	55	70	100	85	4,8
		800 x 240 mm	55	70	120	85	5,3
		800 x 270 mm	55	70	150	85	5,9
		800 x 305 mm	55	70	180	90	6,5
		1000 x 240 mm	55	70	120	85	6,8
		1000 x 270 mm	55	70	150	85	7,5
		1000 x 305 mm	55	70	180	90	8,3

SP P Square Gratings

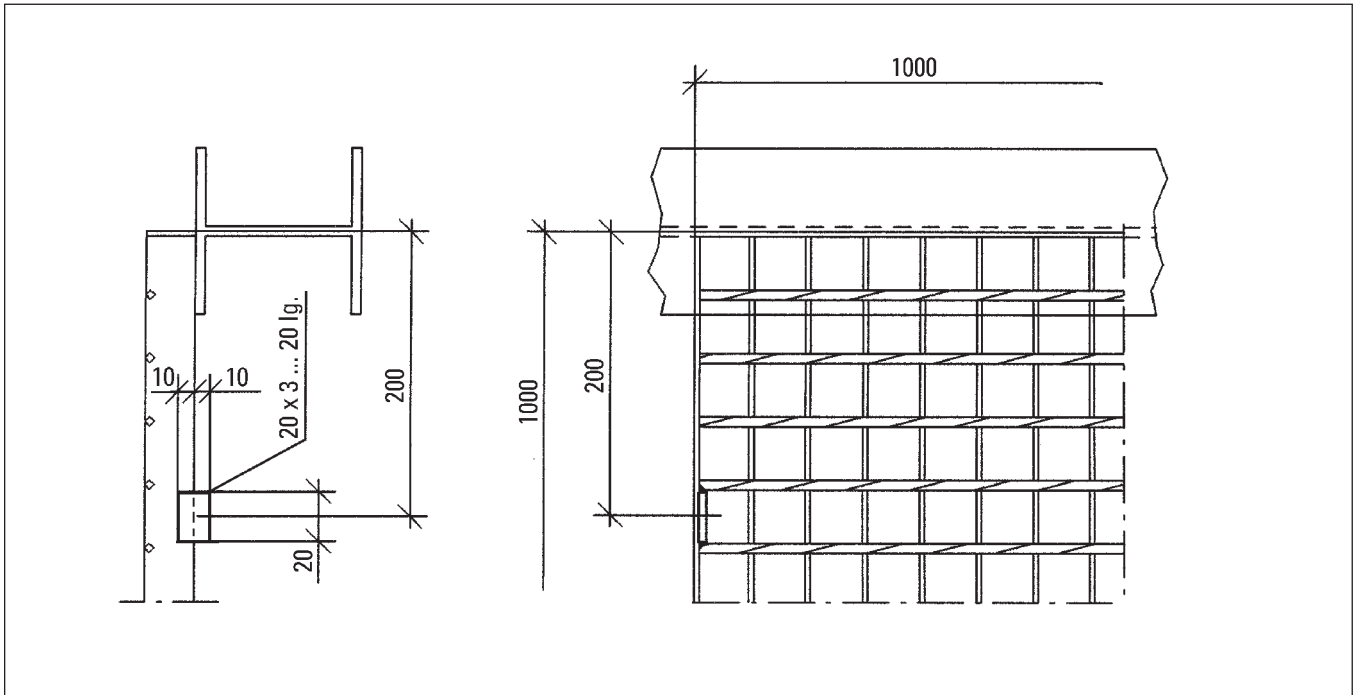

In accordance with the instructions of the professional associations, square gratings should be avoided where only two supports are provided, in order to ensure bearing bars are not running in the wrong direction following erection. Where it is not practical to avoid supplying square gratings, supports should

be provided for all four sides of the grating, or arrangements should be made to prevent installation with bearing bars running in the wrong direction. This can be achieved for example, by welding a 20 x 3 flat bar x 20 mm long, to the side of at least one of the side bearing bars, with at least 10 mm projecting

below the grating, at a suitable distance away from bearing bar supports (see detail). These flat bars can be fixed upon request of the clients

SP P Hazards generated by falling objects

Mesh

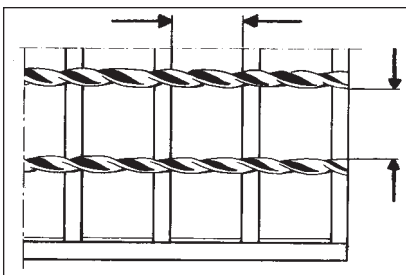

In accordance with the instructions of the professional association (see BGI 588) only gratings for working platforms with a maximum pitch of approximately 34,33 x 50,8 mm are permissible.

Pitch

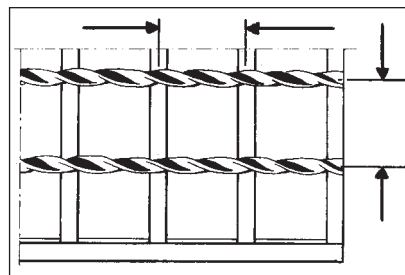

Furthermore is determined in the standard EN ISO 14122 „Safety of machinery - Permanent means of access to machinery - Part 2: Working platforms and walkways“, Article 4.2.4.4. „Hazards ge-

nerated by falling objects“ that „the flooring of a working platform or walkway shall only have such maximum openings that a ball with a diameter of 35 mm cannot fall through.“



P Pressure-Locked Gratings

Roughly 2000 sq.m. of pressure-locked gratings are produced daily and supplied to clients all over the world.

Lichtgitter pressure-locked gratings are used in the industrial sector as well as in civil engineering industries. In addition they are particularly well suited to all types of architectural applications. Pressure-locked gratings are made of steel, stainless steel and aluminum.

Production

Under high pressure, unweakened cross bars are pressed into bearing bars that are S-shaped and/or conically slotted. We have presses at our disposal that provide pressures of up to 20.000 kN for this purpose.

The high pressure and the slit production of the bearing bars guarantee a firm, torsion rigid grating structure. The load distribution is optimum. Thus, even cuts that may be additionally necessary on the construction site have little influence on the stability and usability of the grating structure.

Production sizes

Pressure-locked gratings are produced in all construction heights and thicknesses demanded by the market. Maximum production dimension in direction of cross bars is 1400 mm.

Binding

Pressure-locked gratings with bearing bars of $\varnothing 20 \times 2$ mm up to $\varnothing 40 \times 3$ mm are bound either with flat material or with two stiffening corrugations or angle profiles. Pressure-locked gratings with bearing bars larger than $\varnothing 40 \times 3$ mm are bound with flat material.

Quality standard

Lichtgitter has introduced and continuously developed production techniques that ensure continually high levels of safety. This is maintained by maximum possible automation guaranteeing a high standard of quality for our pressure-locked gratings.

Protection against corrosion

The finished pressure-locked gratings are galvanised according to DIN EN ISO 1461. The zinc coating ensures excellent protection against corrosion (see surface treatment pages 78-81). In special cases, additional protection can be achieved by bitumen dipping, dip or spray painting, plastic coating or other surface treatments (preferably after galvanising).

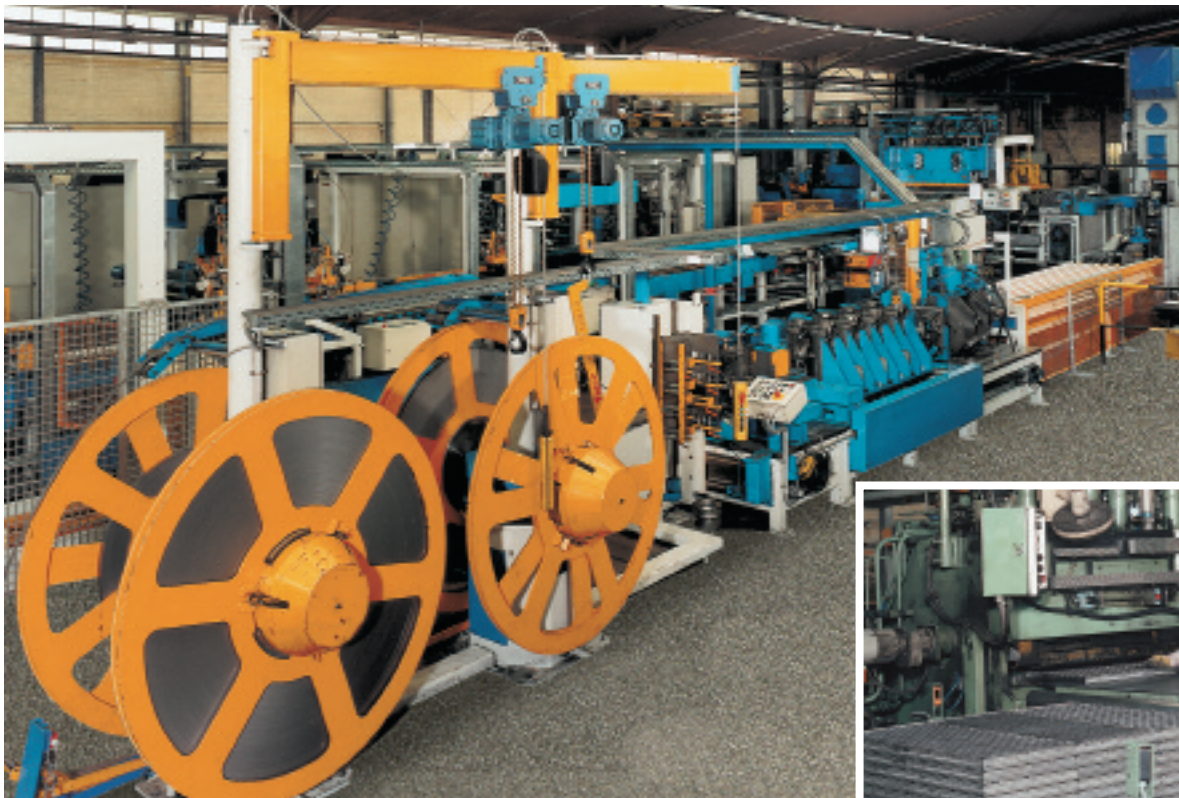
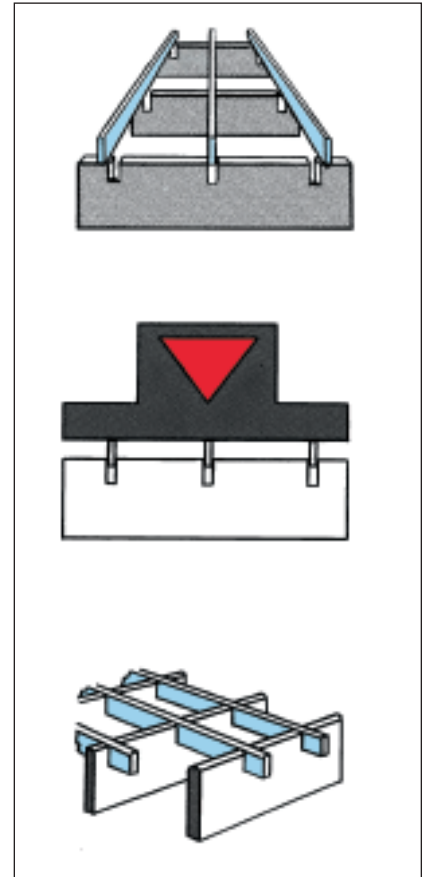

P

Pressure-Locked Gratings

Standard Programme

The flexibility of our production lines allows the fabrication of a large variety of different types of pressure-locked gratings. It is possible to choose for example a square pitch within the range of pitches. A change is also possible within the basic pitches, e.g. bearing bar pitch 22,22 mm, cross bar pitch 33,33 mm. However, the maximum pitch for pedestrian gratings of approx. 33 x 50 mm must be considered according to the instructions of the professional associations.

At a bearing bar thickness of 2 mm, the cross bar thickness is also 2 mm. Otherwise the cross bar is 1 to 2 mm weaker than the bearing bar. Cross bar heights are either 10 mm or 20 mm depending on the height of the bearing bars.

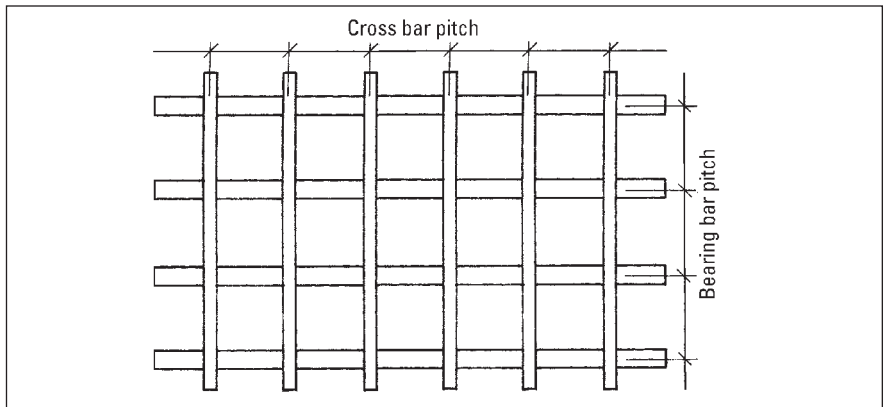

Type designation of pressure-locked gratings

Types of pressure-locked gratings

Fabrication procedure (pressure-locked gratings), bearing bar, pitch and binding are denoted by type designation. Serrated pressure-locked gratings are indicated by an „X“ before type designation (e.g. XP 330-33-3)

Pressure-locked grating	P
Bearing bar \varnothing 30 x 3 mm	330
Pitch 33,33 x 44,44 mm	-33/44
Binding \varnothing 30 x 3 mm	-3
Designation:	P 330 -33/44 -3

With equal pitch of bearing bar and cross bar, pitch is only mentioned one time, e.g. P 330-33-3.

Full cell gratings

Full cell gratings (gratings with bearing bars and cross bars of the same dimension) can be used as decorative elements, e.g. for ceilings, handrails and sunprotection. Full cell gratings can be produced up to a material thickness of 3 mm and up to a maximum height of 60 mm, depending on pitch.

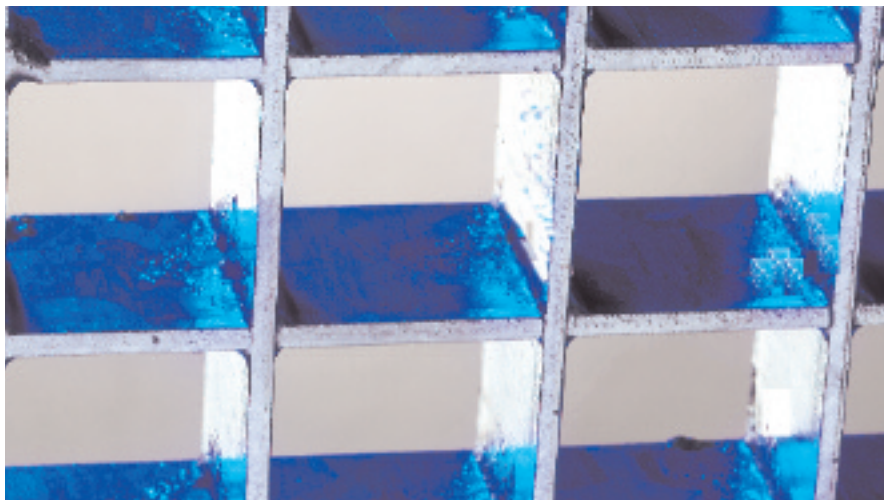

Full cell grating

P Pressure-Locked Gratings

Pressure-locked gratings are used in platforms, walkways, building facades, basement shafts and also for architectural and aesthetic purposes. With gratings of the same size, it is possible to have matching bearing bars and cross bars.

Heavy-duty pressure-locked gratings are also available for vehicle applications. These gratings are particularly suitable for special loads, including the concentrated loads recommended in DIN 1055-5/A1 and 1072, for classes according to SLW. We recommend that an experienced engineer takes care of the calculation.

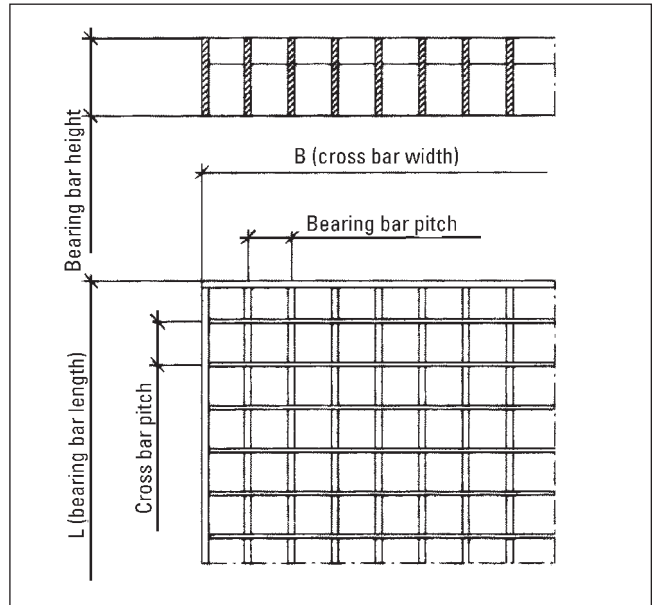
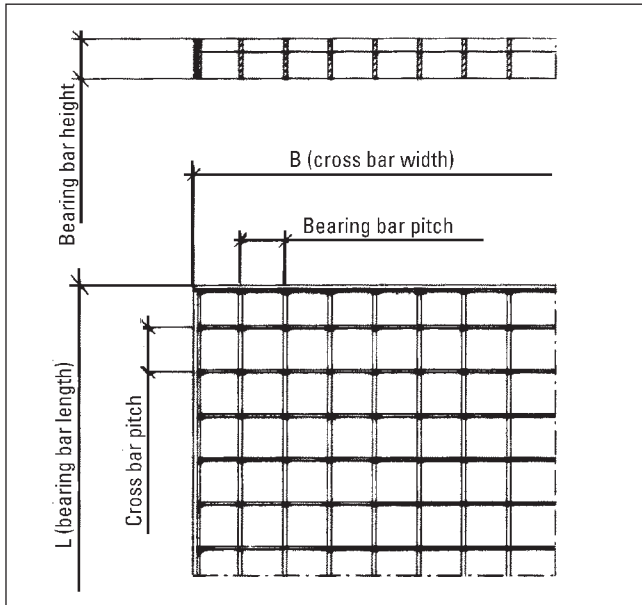
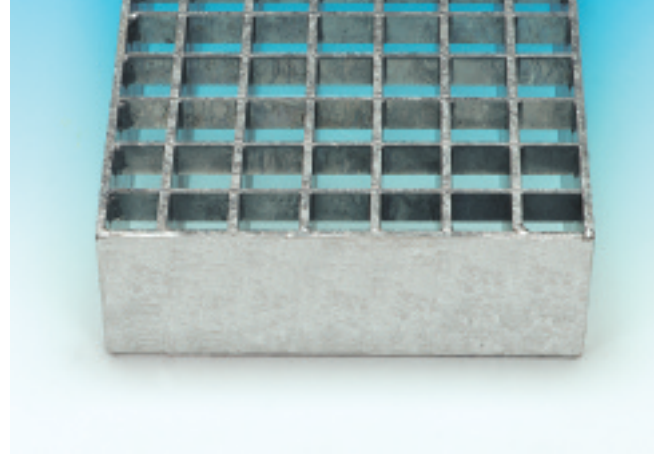
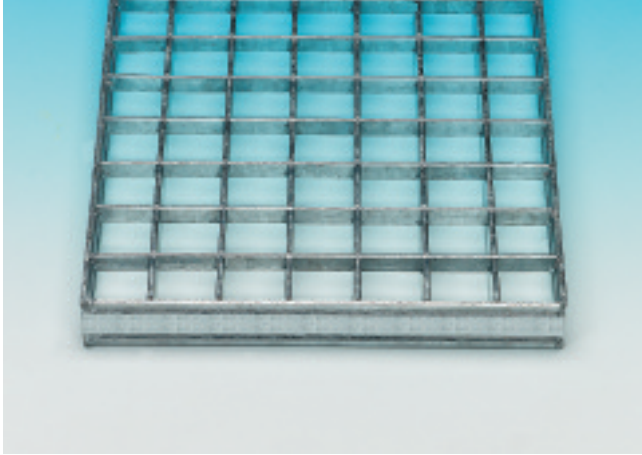

Pressure-locked gratings P Standard		
Bearing bars	Pitches	
	Bearing bar pitch	Cross bar pitch
20 x 2 mm	20 mm	20 mm
25 x 2 mm	22,22 mm	22,22 mm
30 x 2 mm	25 mm	25 mm
40 x 2 mm	33,33 mm	33,33 mm
20 x 3 mm	And a multiple of pitches above. Other pitches on request.	
25 x 3 mm		
30 x 3 mm		
40 x 3 mm		
materials	S 235 JR (± St 37-2), S 355 J2G3 (± St 52-3) stainless steel 1.4301, 1.4571 (from bearing bar 25 x 2 onwards), Aluminum AIMg 3 G 22, AIMg 1 F 15 see page 76/77	
surface		

Pressure-locked gratings P Heavy-duty gratings		
Bearing bar	Pitches	
	Bearing bar pitch	Cross bar pitch
40 x 4 mm	20 mm	20 mm
40 x 5 mm	25 mm	25 mm
50 x 5 mm	33,33 mm	33,33 mm
60 x 5 mm	And a multiple of pitches above. Other heavy-duty gratings on request (e.g. 8 or 10 mm bearing bar thickness)	
up to 120 x 5 mm		
Materials	S 235 JR (± St 37-2), S 355 J2G3 (± St 52-3) stainless steel 1.4301 und 1.4571 Aluminum AIMg 3 G 22, AIMg 1 F 15 see pages 76 / 77	
Surfaces		

P Pressure-Locked Gratings

Serrated pressure-locked gratings with serrated bearing and/or cross bars are approved by the Occupational Safety Authorities. Various anti-slip categories have been established to provide a range of anti-slip levels. The anti-slip levels range from category R9 to R13 (see pages 72 to 75).

Pressure-locked gratings with narrow pitches are used as entrance doormats in pedestrian traffic areas and public places. These gratings are also recommended in the „Berufsgenossenschaft“ professional association’s instruction sheet BGI 588. The length of bearing bars should follow the direction of travel, but if they can only be installed in a different direction, they should be serrated.

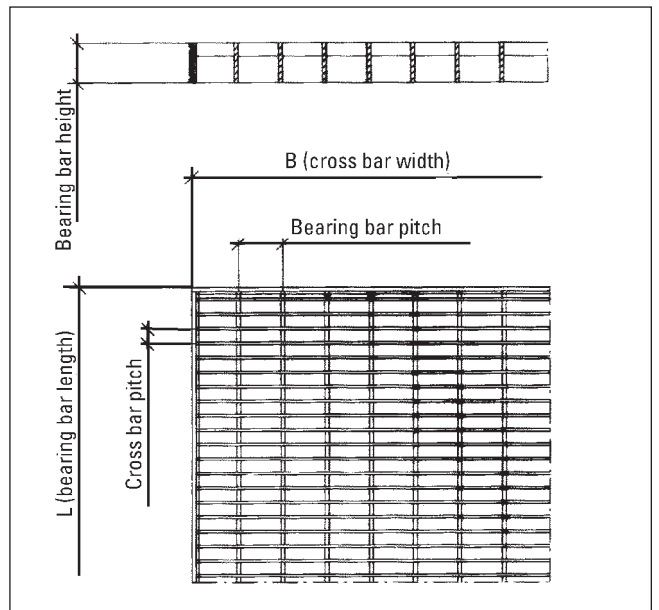
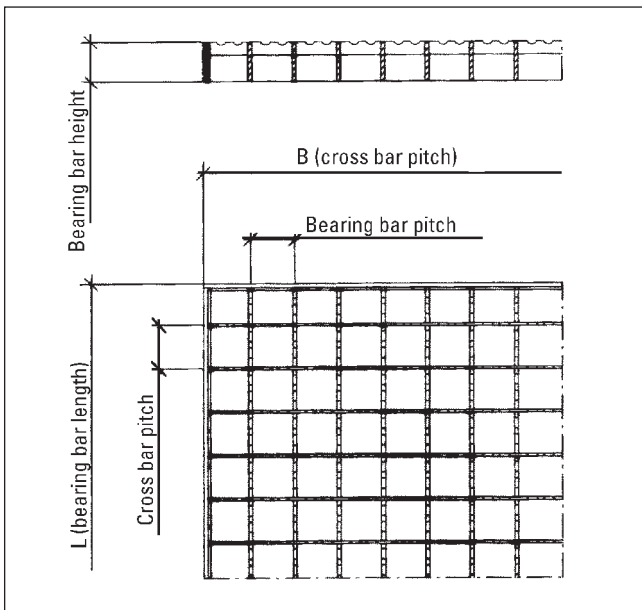
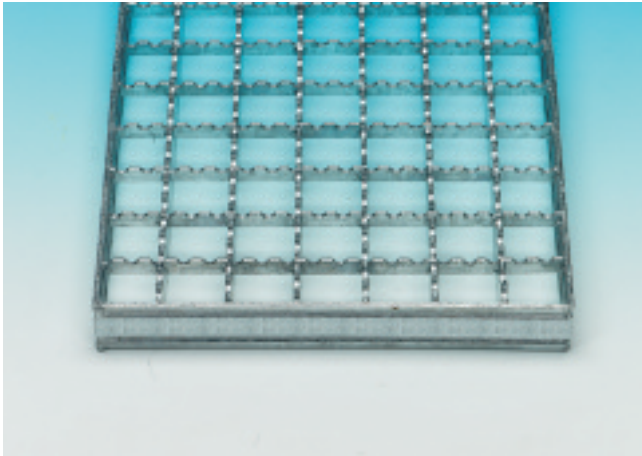

Pressure-locked gratings XP Serration No. 3		
Bearing bars	Pitches	
	Bearing bar pitch	Cross bar pitch
20 x 2 mm	33,33 mm	33,33 mm
25 x 2 mm		
30 x 2 mm	Serration no. 3 is also possible with bearing bars of 4 and 5 mm thickness	
40 x 2 mm		
20 x 3 mm	Other pitches with serration no. 31, 32, 2, 22 and 4 on request.	
25 x 3 mm		
30 x 3 mm		
40 x 3 mm		
Materials	S 235 JR (± St 37-2), S 355 J2G3 (± St 52-3) stainless steel 1.4301, 1.4571 (not 20 x 2) Aluminum AIMg 3 G 22, AIMg 1 F 15 see pages 76 / 77	
Surfaces		

Pressure -locked gratings P Narrow pitch		
Bearing bars	Pitches	
	Bearing bar pitch	Cross bar pitch
20 x 2 mm *	22,22 mm	11,11 mm
25 x 2 mm	33,33 mm	16,65 mm
30 x 2 mm	44,44 mm	
40 x 2 mm	And a multiple of pitches above.	
25 x 3 mm		
30 x 3 mm		
40 x 3 mm		
Materials	S 235 JR (± St 37-2) Stainless steel 1.4301 and 1.4571 Aluminum AIMg 3 G 22, AIMg 1 F 15 see pages 76 / 77	
Surfaces		
Bearing bars marked * cannot be supplied in stainless steel		

P Loadtable for Pressure-Locked Gratings

Grating type	Bearing bar	Pitch	approx. gal. weight kg/m ²	*	Clear span in mm										
					500	600	700	800	900	1000	1100	1200	1300	1400	
P 220-33-3	20 x 2 mm	33 x 33 mm	16,5	F _v	18,45	12,80	9,40	7,20	5,70						
				f	0,20	0,29	0,39	0,51	0,64						
				F _p	1,80	1,45	1,20	1,00	0,90						
				f ₁	0,18	0,26	0,35	0,45	0,57						
P 225-33-3	25 x 2 mm	33 x 33 mm	19,4	F _v	28,80	20,00	14,70	11,25	8,90	7,20	5,95	5,00			
				f	0,16	0,23	0,31	0,41	0,51	0,63	0,77	0,91			
				F _p	2,75	2,20	1,85	1,60	1,40	1,25	1,10	1,00			
				f ₁	0,15	0,21	0,28	0,36	0,45	0,55	0,67	0,79			
P 230-33-3	30 x 2 mm	33 x 33 mm	22,4	F _v	41,50	28,80	21,15	16,20	12,80	10,35	8,55	7,20	6,15	5,30	
				f	0,13	0,19	0,26	0,34	0,43	0,53	0,64	0,76	0,89	1,04	
				F _p	3,95	3,20	2,65	2,25	2,00	1,75	1,60	1,45	1,30	1,20	
				f ₁	0,12	0,17	0,23	0,30	0,38	0,46	0,55	0,66	0,77	0,88	
P 240-33-3	40 x 2 mm	33 x 33 mm	28,1	F _v	73,75	51,20	37,60	28,80	22,75	18,45	15,25	12,80	10,90	9,40	
				f	0,10	0,14	0,19	0,25	0,32	0,40	0,48	0,57	0,67	0,78	
				F _p	6,90	5,55	4,60	3,95	3,45	3,10	2,75	2,50	2,30	2,15	
				f ₁	0,09	0,13	0,17	0,23	0,28	0,35	0,42	0,49	0,57	0,66	
P 320-33-3	20 x 3 mm	33 x 33 mm	21,3	F _v	27,65	19,20	14,10	10,80	8,55	6,90	5,70				
				f	0,20	0,29	0,39	0,51	0,64	0,79	0,96				
				F _p	2,70	2,15	1,80	1,55	1,35	1,20	1,05				
				f ₁	0,18	0,26	0,35	0,45	0,57	0,69	0,83				
P 325-33-3	25 x 3 mm	33 x 33 mm	25,4	F _v	43,0	30,00	22,05	16,90	13,35	10,80	8,90	7,50	6,40	5,50	
				f	0,16	0,23	0,31	0,41	0,51	0,64	0,77	0,91	1,07	1,24	
				F _p	4,15	3,35	2,80	2,40	2,10	1,85	1,65	1,50	1,40	1,30	
				f ₁	0,15	0,21	0,28	0,36	0,45	0,55	0,67	0,79	0,92	1,06	
P 330-33-3	30 x 3 mm	33 x 33 mm	29,5	F _v	62,20	43,20	31,75	24,30	19,20	15,55	12,85	10,80	9,20	7,95	
				f	0,13	0,19	0,26	0,34	0,43	0,53	0,64	0,76	0,89	1,04	
				F _p	5,95	4,75	3,95	3,40	3,00	2,65	2,40	2,15	2,00	1,85	
				f ₁	0,12	0,17	0,23	0,30	0,38	0,46	0,55	0,66	0,77	0,88	
P 340-33-3	40 x 3 mm	33 x 33 mm	37,8	F _v	110,60	76,80	56,45	43,20	34,15	27,65	22,85	19,20	16,35	14,10	
				f	0,10	0,14	0,19	0,25	0,32	0,40	0,48	0,57	0,67	0,78	
				F _p	10,40	8,30	6,90	5,95	5,20	4,60	4,15	3,75	3,45	3,20	
				f ₁	0,09	0,13	0,17	0,23	0,28	0,35	0,42	0,49	0,57	0,66	
P 440-33-4	40 x 4 mm	33 x 33 mm	48,7	F _v	147,50	102,40	75,25	57,60	45,50	36,85	30,45	25,60	21,80	18,80	
				f	0,10	0,14	0,19	0,25	0,32	0,40	0,48	0,57	0,67	0,78	
				F _p	13,80	11,05	9,20	7,90	6,90	6,15	5,55	5,05	4,60	4,25	
				f ₁	0,09	0,13	0,17	0,23	0,28	0,35	0,42	0,49	0,57	0,66	
P 530-33-5	30 x 5 mm	33 x 33 mm	48,3	F _v	103,70	72,00	52,90	40,50	32,00	25,90	21,40	18,00	15,35	13,20	
				f	0,13	0,19	0,26	0,34	0,43	0,53	0,64	0,76	0,89	1,04	
				F _p	9,70	7,80	6,50	5,55	4,85	4,30	3,90	3,55	3,25	3,00	
				f ₁	0,12	0,17	0,23	0,30	0,38	0,46	0,55	0,66	0,77	0,88	
P 540-33-5	40 x 5 mm	33 x 33 mm	62,0	F _v	184,35	128,00	94,05	72,00	56,90	46,10	38,10	32,00	27,25	23,50	
				f	0,10	0,14	0,19	0,25	0,32	0,40	0,48	0,57	0,67	0,78	
				F _p	17,30	13,80	11,50	9,90	8,65	7,70	6,90	6,30	5,75	5,30	
				f ₁	0,09	0,13	0,17	0,23	0,28	0,35	0,42	0,49	0,57	0,66	
P 550-33-5	50 x 5 mm	33 x 33 mm	82,9	F _v	288,00	200,00	146,95	112,50	88,90	72,00	59,50	50,00	42,60	36,75	
				f	0,08	0,11	0,16	0,20	0,26	0,32	0,38	0,46	0,54	0,62	
				F _p	26,50	21,20	17,65	15,15	13,25	11,75	10,60	9,65	8,85	8,15	
				f ₁	0,07	0,10	0,14	0,18	0,23	0,28	0,33	0,39	0,46	0,53	
P 560-33-5	60 x 5 mm	33 x 33 mm	96,6	F _v	414,75	288,00	211,60	162,00	128,00	103,70	85,70	72,00	61,35	52,90	
				f	0,07	0,10	0,13	0,17	0,21	0,26	0,32	0,38	0,45	0,52	
				F _p	37,45	30,00	24,95	21,40	18,75	16,65	15,00	13,60	12,50	11,55	
				f ₁	0,06	0,09	0,12	0,15	0,19	0,23	0,28	0,33	0,38	0,44	

* Key to symbols

F_v = uniformly distributed load (ULD) in kN/m²

f = deflection in cm at load F_v

F_p = concentrated load in kN uniformly distributed over an area of 200 x 200 mm

f₁ = deflection values in cm at load F_p

1 kN = 1000 N = approx. 100 kg

Clear span in mm

1500	1600	1700	1800	1900	2000	2100	2200	2300	2400	2500
8,20	7,20	6,40	5,70	5,10						
0,89	1,02	1,15	1,29	1,43						
1,98	1,84	1,72	1,63	1,54						
0,76	0,86	0,97	1,08	1,20						
6,90	6,10	5,40								
1,19	1,35	1,53								
1,70	1,60	1,50								
1,01	1,15	1,29								
12,30	10,80	9,55	8,55	7,65	6,90	6,30	5,70	5,20		
0,89	1,02	1,15	1,29	1,43	1,59	1,75	1,92	2,10		
2,95	2,75	2,60	2,45	2,30	2,20	2,05	2,00	1,90		
0,76	0,86	0,97	1,08	1,20	1,33	1,46	1,60	1,75		
16,40	14,40	12,75	11,40	10,20	9,20	8,35	7,60	6,95	6,40	5,90
0,89	1,02	1,15	1,29	1,43	1,59	1,75	1,92	2,10	2,29	2,48
3,95	3,70	3,45	3,25	3,05	2,90	2,75	2,65	2,50	2,40	2,30
0,76	0,86	0,97	1,08	1,20	1,33	1,46	1,60	1,75	1,90	2,06
11,50	10,10	8,95	8,00	7,20	6,50	5,90	5,35	4,90		
1,19	1,35	1,53	1,71	1,91	2,12	2,33	2,56	2,80		
2,80	2,60	2,45	2,30	2,15	2,05	1,95	1,85	1,75		
1,01	1,15	1,29	1,44	1,60	1,77	1,95	2,14	2,33		
20,50	18,00	15,95	14,20	12,75	11,50	10,45	9,50	8,70	8,00	7,40
0,89	1,02	1,15	1,29	1,43	1,59	1,75	1,92	2,10	2,29	2,48
4,95	4,60	4,30	4,05	3,85	3,65	3,45	3,30	3,15	3,00	2,90
0,76	0,86	0,97	1,08	1,20	1,33	1,46	1,60	1,75	1,90	2,06
32,00	28,10	24,90	22,20	19,95	18,00	16,30	14,85	13,60	12,50	11,50
0,71	0,81	0,92	1,03	1,15	1,27	1,40	1,54	1,68	1,83	1,98
7,60	7,05	6,60	6,25	5,90	5,60	5,25	5,05	4,80	4,60	4,40
0,61	0,69	0,77	0,87	0,96	1,06	1,17	1,28	1,40	1,52	1,65
46,10	40,50	35,90	32,00	28,70	25,90	23,50	21,40	19,60	18,00	16,60
0,60	0,68	0,76	0,86	0,96	1,06	1,17	1,28	1,40	1,52	1,65
10,70	10,00	9,35	8,80	8,30	7,90	7,50	7,15	6,80	6,50	6,25
0,51	0,57	0,65	0,72	0,80	0,89	0,98	1,07	1,17	1,27	1,37

Data

Material stress (permissible tension):

16 kN/cm² (Material S235JR $\hat{=}$ St 37-2)

Safety factor to yield point: 1,5

Safety factor to breaking limit: 2,05

The **grating support** should provide a bearing distance at each end of at least 25 mm. Deviations may be permitted, providing suitable measures are taken to prevent excessive movement in the direction of bearing bars (see instruction sheet BGI 588).

Pedestrian traffic

Yellow: Gratings manufactured in accordance with the requirements of instruction sheet BGI 588 of the „Berufsgenossenschaft“ professional association and to quality instructions RAL-GZ 638, are considered suitable for pedestrian traffic when they meet the following design criteria:

The maximum permissible deflection ‘f’, does not exceed 1/200th of the span ‘L’ or 4 mm whichever is the lesser, under a concentrated load of 1,5 kN applied in the most unfavourable position, over a concentrated load area of 200 x 200 mm

Green: The maximum permissible deflection ‘f’, does not exceed 1/200th of the span ‘L’, under a concentrated load of 1,5 kN applied in the most unfavourable position, over a concentrated load area of 200 x 200 mm.

Blue: The maximum permissible deflection ‘f’, does not exceed 1/200th of the span ‘L’, under a uniformly distributed load of 5 kN/m².

Multiplication factor

Pitch	distributed load	single load
22,22	1,50	1,35
25,00	1,33	1,24
40,00	0,83	0,88
44,44	0,75	0,82
50,00	0,66	0,75
66,66	0,50	0,61

Multiplication factor for other materials

Material	load	deflection
Stainless steel 1.4301	0,82	0,84
Stainless steel 1.4571	0,88	0,90
Aluminium AlMg 3 G 22	0,54	1,61

For concentrated loads, the conversion factor indicated can only be approximate due to the varying number of adjoining bearing bars either side of the concentrated load area, therefore the load considered should generally be that determined by the depths of bearing bars and the number under the concentrated load area.

P Standard Gratings and stairtreads

Delivery ex our stock

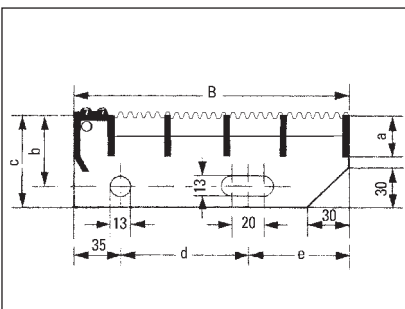
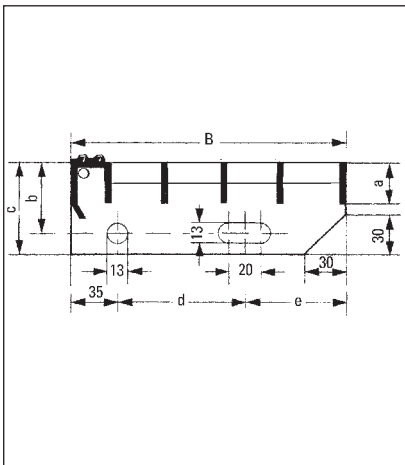
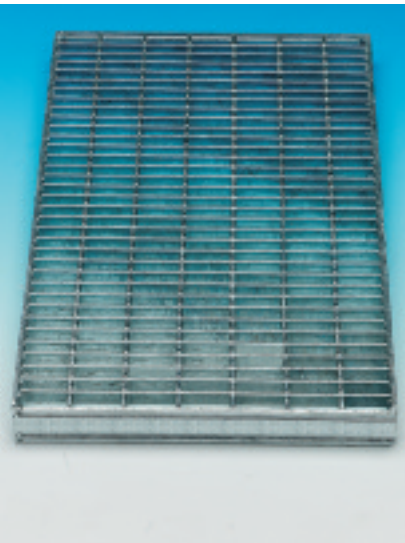
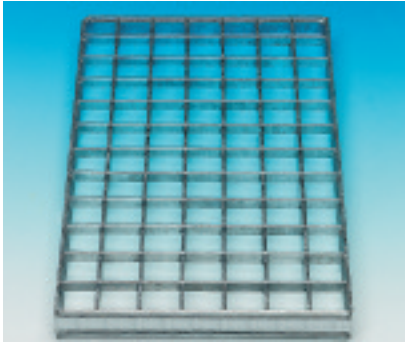

Standard Pressure-Locked Gratings with binding					
Type	Dimension in mm	kg/piece	Type	Dimension in mm	kg/piece
P 230-33-3	500 x 1000	11,8	P 330-33-3	500 x 1000	15,5
	600 x 1000	13,9		600 x 1000	18,2
	700 x 1000	16,0		700 x 1000	21,0
	800 x 1000	18,1		800 x 1000	23,9
	900 x 1000	20,2		900 x 1000	26,4
	1000 x 1000	22,3		1000 x 1000	29,5
	1100 x 1000	24,4		1100 x 1000	32,4
1200 x 1000	26,5	1200 x 1000	35,3		

Standard Pressure-Locked Gratings with narrow pitch with binding					
Type	Dimension in mm	kg/piece	Type	Dimension in mm	kg/piece
P 230-33/11-3	500 x 1000	16,8	P 230-33/11-3	900 x 1000	29,2
	600 x 1000	19,8		1000 x 1000	32,3
	700 x 1000	23,0		1100 x 1000	35,4
	800 x 1000	26,1		1200 x 1000	38,5

Pressure-Locked Panels self coloured with binding, dimension: 3000 x 1000 mm					
Type	Bearing bar	kg/m ²	Type	Bearing bar	kg/m ²
P 225-33-2	25 x 2	17,0	P 225-33/11-2	25 x 2	26,3
P 230-33-2	30 x 2	19,5	P 230-33/11-2	30 x 2	28,9
P 240-33-2	40 x 2	24,3	P 240-33/11-2	40 x 2	33,6
P 330-33-3	30 x 3	26,8	P 330-33/11-3	30 x 3	36,0
P 340-33-3	40 x 3	34,3	P 340-33/11-3	40 x 3	43,7
XP 230-33-2 (no.3)	30 x 2	19,3	XP 230-33/11-2 (no.42)	30 x 2	29,3
XP 330-33-3 (no.3)	30 x 3	26,6	XP 330-33/11-3 (no.42)	30 x 3	36,7

Pressure-Locked stairtreads ex stock							
Type	Bearing bar	Dimension	b	c	d	e	kg/piece
P 230-33-3	30 x 2 mm	600 x 205 mm	55	70	90	80	3,5
P 230-33-3	30 x 2 mm	600 x 240 mm	55	70	120	85	4,2
P 230-33-3	30 x 2 mm	600 x 270 mm	55	70	150	85	4,6
P 230-33-3	30 x 2 mm	800 x 240 mm	55	70	120	85	5,3
P 230-33-3	30 x 2 mm	800 x 270 mm	55	70	150	85	5,9
P 230-33-3	30 x 2 mm	800 x 305 mm	55	70	180	90	6,6
P 230-33-3	30 x 2 mm	1000 x 240 mm	55	70	120	85	6,8
P 230-33-3	30 x 2 mm	1000 x 270 mm	55	70	150	85	7,6
P 230-33-3	30 x 2 mm	1000 x 305 mm	55	70	180	90	8,0
P 330-33-3	30 x 3 mm	1000 x 240 mm	55	70	120	85	8,2
P 330-33-3	30 x 3 mm	1000 x 270 mm	55	70	150	85	9,2
P 330-33-3	30 x 3 mm	1000 x 305 mm	55	70	180	90	10,3
P 340-33-3	40 x 3 mm	1200 x 240 mm	55	70	120	85	11,8
P 340-33-3	40 x 3 mm	1200 x 270 mm	55	70	150	85	13,2
P 340-33-3	40 x 3 mm	1200 x 305 mm	55	70	180	90	14,8

Narrow pitch steps ex stock							
Type	Bearing bar	Dimension	b	c	d	e	kg/piece
plain							
P 230-33/11-3	30 x 2 mm	800 x 240 mm	55	70	120	85	6,9
P 230-33/11-3	30 x 2 mm	800 x 270 mm	55	70	150	85	7,9
P 230-33/11-3	30 x 2 mm	1000 x 240 mm	55	70	120	85	9,0
P 230-33/11-3	30 x 2 mm	1000 x 270 mm	55	70	150	85	10,0
serrated execution (serration no. 42)							
XP 230-33/11-3	30 x 2 mm	800 x 240 mm	55	70	120	85	7,5
XP 230-33/11-3	30 x 2 mm	800 x 270 mm	55	70	150	85	8,4
XP 230-33/11-3	30 x 2 mm	800 x 305 mm	55	70	180	90	9,4
XP 230-33/11-3	30 x 2 mm	1000 x 240 mm	55	70	120	85	9,6
XP 230-33/11-3	30 x 2 mm	1000 x 270 mm	55	70	150	85	10,8
XP 230-33/11-3	30 x 2 mm	1000 x 305 mm	55	70	180	90	12,0
XP 330-33/11-3	30 x 3 mm	1000 x 240 mm	55	70	120	85	10,9
XP 330-33/11-3	30 x 3 mm	1000 x 270 mm	55	70	150	85	12,3
XP 330-33/11-3	30 x 3 mm	1000 x 305 mm	55	70	180	90	13,8

Heavy-duty gratings with appropriate sizes correctly determined, are suitable for wheel loading and other heavy-duty loads. Specific details of various loading and load areas can be obtained from the relevant DIN instructions.

Load table page 30
for material S235JR Δ St 37-2
Load table page 31
for material S355J2G3 Δ St 52-3
(only pressure-locked gratings)

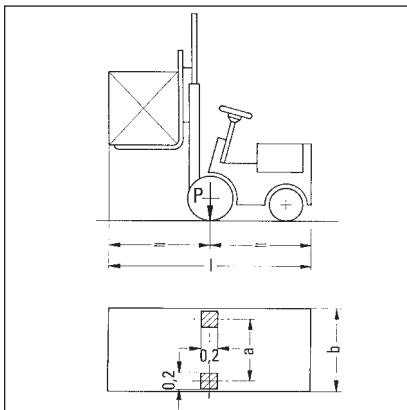
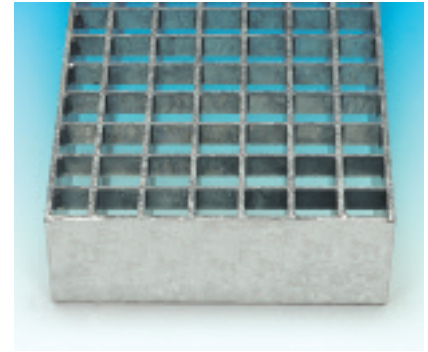
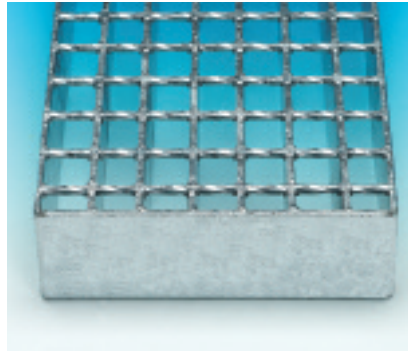

Extract from DIN 1055-5/A1

Fork lift - standard vehicles

Allowable total weight	Nominal load capacity	Static axial load (standard load) P	Central trace width a	Total width b	Total length l	Uniformly distributed traffic load (standard load)
kN	kN	kN	m	m	m	kN/m ²
25	6	20	0,8	1,0	2,4	10
35	10	30	0,8	1,0	2,8	12,5
70	25	65	1,0	1,2	3,4	15
130	50	120	1,2	1,5	3,6	25

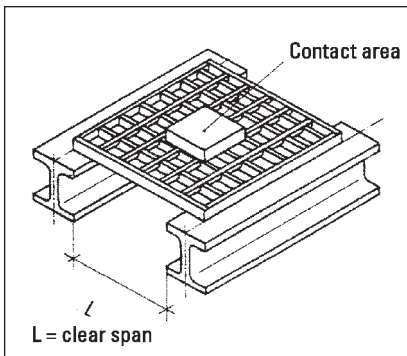

Extract from DIN 1072

Oscillation value	Bridge class*	Wheel load	Load area ⁺
If traffic lane contains construction parts that are particularly susceptible to localised brake loading (e.g. parts of traffic lane crossings, gratings, etc.), wheel loads should be multiplied by 1,4 to determine brake loading occurring on single parts.	60	100 kN	200 x 600 mm
	45	75 kN	200 x 500 mm
	30	50 kN	200 x 400 mm
	24	40 kN	200 x 300 mm
	16	50 kN	200 x 400 mm
	12	40 kN	200 x 300 mm
	9	30 kN	200 x 260 mm
6	20 kN	200 x 200 mm	
3	10 kN	200 x 200 mm	

* Bridge class = total weight of the vehicle

+ Load area = Load contact area

Lichtgitter load table for wheel loads

How to use Lichtgitter load table for wheel loads (see pages 30 & 31)

Table for forge-welded gratings with bearing bar pitch of 34,33 mm and pressure-locked gratings with bearing bar pitch of 33,33 mm are shown in standard types, however, pressure-locked gratings with bearing bar thickness of 8 mm or 10 mm are also available upon request.

Material stress (permissible stress) 16 kN/cm² (Material S235JR Δ St 37-2)

Material stress (permissible stress) 24 kN/cm² (Material S355J2G3 Δ St 52-3)

Safety factor to yield point is 1,50.

Safety factor to breaking limit is 2,05.

Maximum deflection not more than 1/200 of span.

Table shows clear span.

Example:

Wheel load

50/70

Wheel load including oscillation value ϕ 1,4

Span at 50 kN wheel load

480/400

Span at 70 kN wheel load

Start at 50 kN, then consider a span of say 480 mm, at the load contact area specified of 200 x 400 mm.

The bearing bar dimensions of 60 x 5 mm are indicated in the column on the left hand side.

According to DIN, certain wheel loads are coordinated to specific load contact areas (see 'Extract from DIN 1072'). The resulting maximum recommended spans shown for specific bearing bar dimensions, are marked by a surrounding red line.

bearing bar dimension	approx. gal. weight kg/m ²	contact area in mm	Wheel load in kN					contact area in mm	Wheel load in kN			
			4,50/6,30	7,50/10,50	10/14	20/28	30/42		40/56	50/70	75/105	100/140
25 x 2 mm	P = 19,4 SP = 18,7	100 x 100	220/170	150/120	170/140	120/110		200 x 300				
		150 x 150	280/220	200/160	210/170	150/130	130/120	200 x 400				
		200 x 200			230/190	160/140	140/130	200 x 500				
		200 x 260						200 x 600				
25 x 3 mm	P = 25,4 SP = 24,5	100 x 100	300/230	200/160	160/130			200 x 300				
		150 x 150	380/290	260/210	210/170	140/120		200 x 400				
		200 x 200			260/210	180/150	150/130	200 x 500				
		200 x 260			290/240	210/180	180/160	200 x 600				
30 x 2 mm	P = 22,4 SP = 21,5	100 x 100	290/220	190/150	160/130			200 x 300				
		150 x 150	370/280	250/200	210/170	140/120		200 x 400				
		200 x 200			250/210	170/150	150/130	200 x 500				
		200 x 260			280/240	200/180	170/160	200 x 600				
30 x 3 mm	P = 29,5 SP = 28,5	100 x 100	410/300	260/200	210/160			200 x 300	170/150	160/140		
		150 x 150	510/390	340/260	270/210	170/140		200 x 400	190/170	170/150	150/130	
		200 x 200			330/260	210/180	170/150	200 x 500		190/160	160/140	
		200 x 260			360/290	240/210	200/180	200 x 600			170/150	150/130
40 x 2 mm	P = 28,1 SP = 27,2	100 x 100	460/340	300/230	230/180			200 x 300	190/160	170/150		
		150 x 150	580/440	380/290	300/240	190/150		200 x 400	210/180	190/160	160/140	
		200 x 200			370/290	230/190	190/160	200 x 500		210/170	170/150	150/130
		200 x 260			400/320	260/220	210/190	200 x 600			180/160	160/140
40 x 3 mm	P = 37,8 SP = 36,5	100 x 100	660/490	420/310	330/250			200 x 300	230/190	210/170		
		150 x 150	840/620	530/400	420/320	250/200		200 x 400	270/220	230/190	190/160	
		200 x 200			510/390	300/240	230/190	200 x 500		260/210	210/170	180/150
		200 x 260			540/420	330/270	260/220	200 x 600			220/190	190/160
40 x 4 mm	P = 48,7 SP = 47,0	100 x 100	870/640	550/410	420/320			200 x 300	280/240	240/200		
		150 x 150	1100/810	690/510	530/400	300/240		200 x 400	320/260	280/240	220/180	
		200 x 200			650/490	370/290	280/240	200 x 500		320/250	240/200	210/170
		200 x 260			680/520	400/320	310/260	200 x 600			270/220	220/190
40 x 5 mm	P = 62,0 SP = 59,4	100 x 100	1070/780	660/490	510/380			200 x 300	310/260	280/240		
		150 x 150	1350/990	840/620	650/480	360/280		200 x 400	360/310	320/260	250/210	
		200 x 200			790/590	440/340	330/260	200 x 500		370/290	280/230	230/190
		200 x 260			810/620	470/370	350/290	200 x 600			310/250	260/210
50 x 5 mm	P = 82,9 SP = 72,7	100 x 100	1600/1160	980/720	750/550			200 x 300	400/330	350/290		
		150 x 150	2030/1470	1250/910	950/700	510/390		200 x 400	450/370	400/340	330/260	
		200 x 200			1150/850	620/470	450/350	200 x 500		440/380	370/300	310/250
		200 x 260			1180/880	650/500	480/370	200 x 600			420/330	340/270
60 x 5 mm	P = 96,6 SP = 86,0	100 x 100	2230/1610	1360/980	1030/750			200 x 300	510/410	440/350		
		150 x 150		1720/1250	1310/960	690/520		200 x 400	560/450	480/400	380/330	
		200 x 200			1590/1170	840/630	590/450	200 x 500		530/440	430/370	380/310
		200 x 260				870/700	620/480	200 x 600			470/420	420/350
70 x 5 mm	P = 110,3 SP = 99,3	100 x 100		1770/1280	1340/970			200 x 300	640/500	540/430		
		150 x 150			1720/1250	900/660		200 x 400	680/540	580/470	450/380	
		200 x 200			2090/1520	1090/810	760/570	200 x 500		630/520	500/420	430/370
		200 x 260			2120/1550	1120/840	790/600	200 x 600			540/470	470/420
80 x 5 mm	P = 124,0 SP = 112,5	100 x 100			1690/1220			200 x 300	780/600	650/510		
		150 x 150			2170/1570	1120/820		200 x 400	820/640	700/550	530/430	
		200 x 200				1370/1010	950/700	200 x 500		740/600	570/470	490/410
		200 x 260				1400/1040	980/730	200 x 600			620/520	530/460
90 x 5 mm	P = 137,7	100 x 100						200 x 300	930/710	780/590		
		150 x 150				1370/1000		200 x 400	980/750	820/640	610/490	
		200 x 200				1680/1230	1150/850	200 x 500		870/680	650/530	550/460
		200 x 260				1710/1260	1180/880	200 x 600			700/580	590/500
100 x 5 mm	P = 151,4	100 x 100						200 x 300	1100/830	910/690		
		150 x 150				1630/1190		200 x 400	1150/870	950/730	700/550	
		200 x 200				2020/1470	1380/1010	200 x 500		1000/780	740/600	610/500
		200 x 260				2040/1490	1400/1040	200 x 600			790/640	660/550
110 x 5 mm	P = 165,1	100 x 100						200 x 300	1290/960	1060/800		
		150 x 150				1940/1400		200 x 400		1110/840	800/620	
		200 x 200				2400/1740	1630/1190	200 x 500		1150/890	840/670	690/560
		200 x 260				2420/1760	1660/1220	200 x 600			890/710	740/600
120 x 5 mm	P = 178,8	100 x 100						200 x 300	1490/1110	1220/910		
		150 x 150						200 x 400	1540/1150	1270/960	910/700	730/570
		200 x 200					1900/1390	200 x 500		1310/1010	950/750	770/620
		200 x 260					1930/1410	200 x 600			1000/790	820/660

1 kN = 1000 N = approx. 100 kg

bearing bar dimension	approx. gal. weight kg/m ²	contact area in mm	Wheel load in kN					contact area in mm	Wheel load in kN					
			4,50/6,30	7,50/10,50	10/14	20/28	30/42		40/56	50/70	75/105	100/140		
25 x 2 mm	P = 19,4							200 x 300						
		100 x 100	300/220	200/150				200 x 400						
		150 x 150	325/250	225/180	185/155	130/115		200 x 500						
		200 x 200			265/215	180/155	155/135	200 x 600						
25 x 3 mm	P = 25,4							200 x 300						
		100 x 100	425/315	275/210	215/170			200 x 400						
		150 x 150	540/405	350/270	280/220	175/145		200 x 500						
		200 x 200			350/275	225/190	180/160	200 x 600						
30 x 2 mm	P = 22,4							200 x 300						
		100 x 100	405/300	260/200	210/160			200 x 400						
		150 x 150	515/390	340/260	270/215	170/145		200 x 500						
		200 x 200			335/270	215/180	180/155	200 x 600						
30 x 3 mm	P = 29,5							200 x 300	230/190	205/175				
		100 x 100	580/430	370/275	290/220			200 x 400	260/215	230/190	185/160			
		150 x 150	735/545	470/360	370/285	220/180		200 x 500		240/200	190/165			
		200 x 200			455/350	275/225	215/185	200 x 600			205/175	180/155		
40 x 2 mm	P = 28,1							200 x 300	235/195	210/175				
		100 x 100	660/485	415/310	325/245			200 x 400	270/220	235/195	190/165			
		150 x 150	840/620	535/400	420/320	245/195		200 x 500		265/215	210/175	180/160		
		200 x 200			540/425	335/275	265/225	200 x 600			230/190	195/170		
40 x 3 mm	P = 37,8							200 x 300	305/245	265/215				
		100 x 100	995/725	615/455	475/355			200 x 400	360/285	305/245	235/195			
		150 x 150	1100/895	765/565	590/445	330/260		200 x 500		345/275	265/215	220/185		
		200 x 200			720/540	410/320	305/245	200 x 600			290/235	245/200		
40 x 4 mm	P = 48,7							200 x 300	370/290	320/250				
		100 x 100	1150/920	770/570	600/440			200 x 400	430/340	370/290	290/220			
		150 x 150	1250/1150	990/730	760/560	420/310		200 x 500		420/330	320/250	260/210		
		200 x 200			920/690	510/390	370/290	200 x 600			350/280	290/230		
40 x 5 mm	P = 62,0							200 x 300	440/340	370/290				
		100 x 100	1250/1140	970/700	740/540			200 x 400	510/400	430/340	320/260			
		150 x 150	1400/1200	1100/890	900/690	500/380		200 x 500		490/390	370/290	300/240		
		200 x 200			1050/840	600/470	430/340	200 x 600			410/320	340/270		
50 x 5 mm	P = 82,9							200 x 300	540/430	460/370				
		100 x 100	1750/1450	1300/1000	1100/800			200 x 400	590/480	510/420	400/350			
		150 x 150	2000/1650	1600/1250	1300/1000	730/540		200 x 500		560/470	450/400	410/320		
		200 x 200			1450/1220	880/660	620/470	200 x 600			500/450	460/360		
60 x 5 mm	P = 96,6							200 x 300	700/540	590/470				
		100 x 100	2250/1900	1750/1430	1500/1080			200 x 400	750/590	640/520	490/410			
		150 x 150		2000/1700	1650/1400	1000/730		200 x 500		690/570	540/460	470/410		
		200 x 200			1900/1600	1220/900	840/630	200 x 600			590/510	520/460		
70 x 5 mm	P = 110,3							200 x 300	900/680	750/570				
		100 x 100		2200/1800	1850/1400			200 x 400	950/730	800/620	590/480			
		150 x 150			2150/1830	1300/950		200 x 500		850/670	640/530	550/460		
		200 x 200			2300/1970	1570/1170	1080/810	200 x 600			690/580	600/510		
80 x 5 mm	P = 124,0							200 x 300	1100/830	900/690				
		100 x 100			2250/1800			200 x 400	1150/880	950/740	700/560			
		150 x 150			2550/2170	1640/1190		200 x 500		1000/790	750/610	630/520		
		200 x 200				2040/1470	1370/1010	200 x 600			800/660	680/570		
90 x 5 mm	P = 137,7							200 x 300	1320/1000	1100/830				
		100 x 100						200 x 400	1370/1050	1150/880	830/650			
		150 x 150				2010/1460		200 x 500		1190/930	880/700	720/590		
		200 x 200				2350/1800	1680/1230	200 x 600			930/750	770/640		
100 x 5 mm	P = 151,4							200 x 300	1570/1170	1280/960				
		100 x 100						200 x 400	1620/1220	1330/1010	960/740			
		150 x 150				2410/1740		200 x 500		1380/1060	1010/790	820/650		
		200 x 200				2750/2150	2020/1470	200 x 600			1060/840	870/710		
110 x 5 mm	P = 165,1							200 x 300	1870/1370	1770/1310				
		100 x 100						200 x 400	1920/1420	1570/1180	1280/970			
		150 x 150				2800/2090		200 x 500		1870/1410	1170/910	935/710		
		200 x 200				3150/2580	2420/1750	200 x 600			1380/1070	980/790		
120 x 5 mm	P = 178,8							200 x 300	2150/1600	1750/1300				
		100 x 100						200 x 400	2200/1650	1800/1350	1280/970	1000/780		
		150 x 150						200 x 500		1850/1400	1320/1020	1050/840		
		200 x 200					2860/2070	200 x 600			1380/1070	1100/880		

1 kN = 1000 N = approx. 100 kg

SP P Fixings for Gratings

Fixings are available for all types of standard Lichtgitter gratings and for any type of underside support. Lichtgitter fixings are specifically designed to suit gratings subjected to **pedestrian traffic**. Gratings subjected to loadings from **vehicle traffic**, can be supplied with hole plates upon request. These are small plates welded between bearing bars, complete with holes for fixing.

In accordance with the professional association's instruction sheet BGI 588, „For areas in danger of falling, gratings should at least be fixed at their four edge points“.

With regard to the fixing of gratings, we would refer to the „Arbeitsstätten-Verordnung § 12, Protection against falling and objects being thrown down“, with particular reference to instruction sheet

H 10, „Gratings for industrial use“: page 5, paragraph 5.2.:

„Gratings are to be protected against lifting and slipping. Every single grating is to be attached to substructure in at least four places.“

Fixings no. B334K, B351K, B433T, B533K and B633K prevent slippage from underside support, even when attachment loosens.

All fixings require service and should be regularly inspected regarding their efficiency. The inspection intervals depend on operating conditions. The user may have to **hand-screw** fixings.

Therefore, all fixing materials are excluded from legal warranty.

If not specifically required otherwise, all fixing parts, including screws and nuts,

will be supplied centrifugally galvanised. Consideration should be given to the length of screws required, in order to be able to install the fixings through the grating from above.

The reference number for fixings used for gratings with pitches ranging from 20 to 66 mm, varies in so far as the last two figures of the number, indicates the pitch:

e.g. Standard-Fixing with
Pitch 33,33 mm = B133K,
Pitch 22,22 mm = B122K.

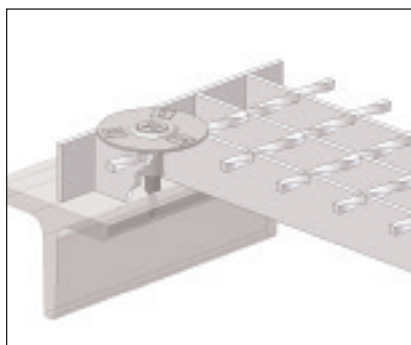
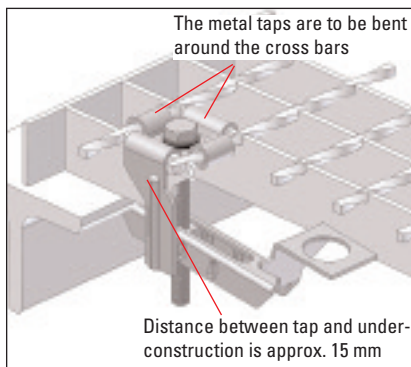

Fixings for forge-welded gratings with locking devices B 334K / B 351K

Order Number B 334 K (suitable for pitch 34 x 38 mm)

Order Number B 351 K (suitable for pitch 34 x 50 mm)

Consisting of:

- clamp upper part
- under part with finger hole
- screw, nut and washer.

Length of screws at least height of grating plus 50 mm.

This type of fixing prevents slippage of gratings from the underside support, even when the screw loosens.

Threaded bolt fixings B 433 T

Consisting of:

- top clamp with fixed, connected, threaded bush out of brass or aluminum
- threaded bolts.

This entire fixing unit can be supplied in stainless steel.

This type of fixing can be installed from above and prevents slippage of gratings from the underside support, even when the screw loosens.

This fixing is suitable for pitches ranging from approximately 25 to 40 mm.

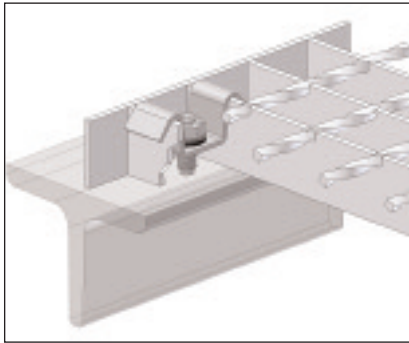

Welded Bolt Fixings B 533 K

Consisting of:

- deep drawn clamp upper part (on request with deep drawn plate)
- welded bolt (copper backed-up and nickel plated) including ceramic ring
- self-locking nut and, if necessary, with washer.

This type of fixing can be installed from above and prevents slippage of gratings from the underside support, even when the screw loosens.

This fixing is suitable for pitches ranging from approximately 25 to 40 mm.

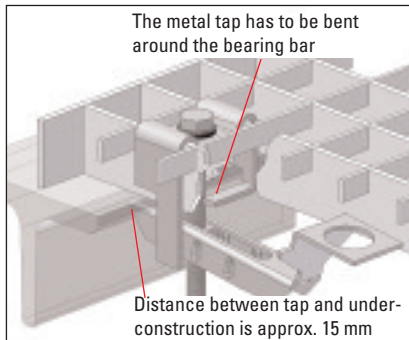

Fixings for pressure-locked gratings with locking devices B 633 K

(Suitable for bearing bar pitches of 33 mm and equal or greater cross bar pitches)

Consisting of:

- clamp upper part
- under part with finger hole
- screw, nut and washer.

The length of screw should be at least the height of the grating, plus 50 mm.

This type of fixing can be installed from above and prevents slippage of gratings from the underside support, even when the screw loosens.

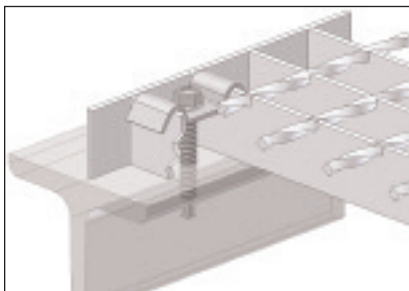

Fixings with self tapping screw B 233 K

Consisting of:

- top clamp
- self-tapping screw at site.

This fixing can be installed from above.

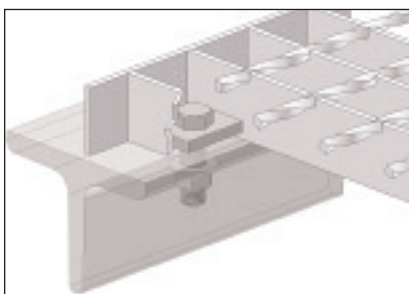

Fixings with hole plate B 270

Consisting of:

- welded in hole plate
- screw at site.

This method of fixing is specifically suitable for gratings subjected to vehicle traffic.

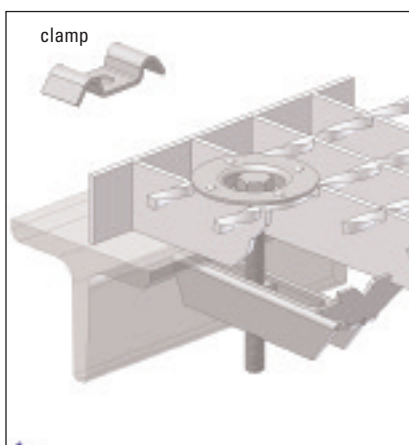

Standard fixings B 133 T & B 133 K

Consisting of:

- clamp upper part or plate
- under part
- screw, nut and washer.

This fixing can be delivered in stainless steel; order-no. B 132 K.

The length of screw should be at least the height of the grating, plus 30 mm.

This fixing can be assembled from above at pitches of 33 mm and over and upon request it can be supplied with a raised 'beard'.

According to the instructions of the German Employer's Liability Insurance Association only permissible if an additional locking device preventing a displacement on site is available.

SP P Fixings

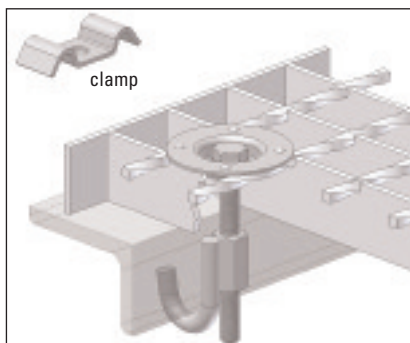

Hook screw fixings B 733 K & B 733 T

Consisting of :

- clamp upper part or plate
- hook screw, adjusted to underside support
- M 8 x 90 screw, nut and washer

Profile of underside support must be given.

This fixing can be assembled from above.

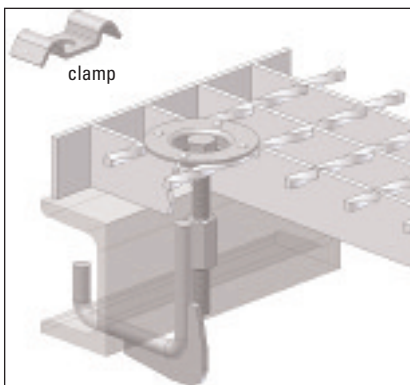

Hook screw fixings B 833 K & B 833 T

Consisting of:

- clamp upper part or plate
- hook screw, adjusted to the underside support
- M 8 x 90 screw, nut and washer.

Profile of underside support must be given.

This fixing can be assembled from above.

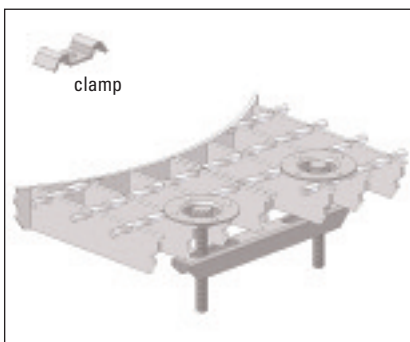

Double clamp fixings B 933 T & B 933 K

Consisting of:

- clamp upper part or plate
- under part
- screw, nut and washer.

The length of screw should be at least the height of the grating, plus 30 mm.

Double clamp fixing connects adjacent gratings at places tending to have excessive deflections and therefore prevents the occurrence of trip hazards. This fixing can be assembled from above the grating.

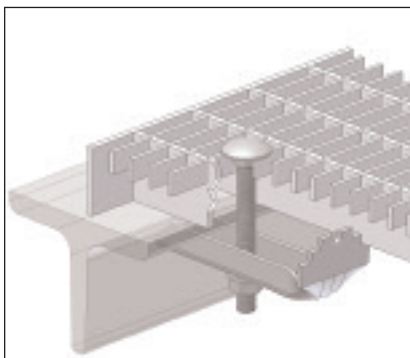

Fixings B 10

For pressure-locked gratings with cross bar pitch at 11,11 mm

Consisting of:

- under part
- galvanized round-head bolt and nut.

The length of screw should be at least the height of the grating, plus 40 mm.

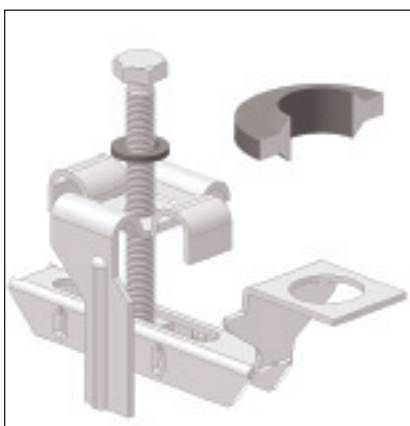

Washer

results in an improvement of bolt connection.

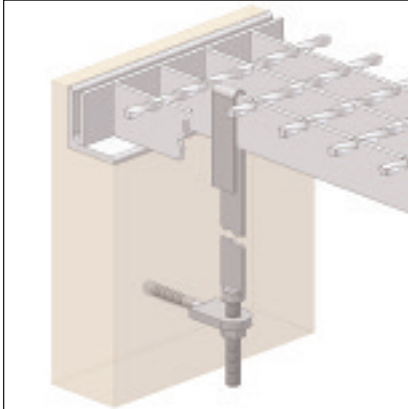

Safety hook / Fixing B 11

- Consisting of:
- stainless steel safety hook with threaded end
 - stainless steel nut
 - screw anchor including synthetic plug.

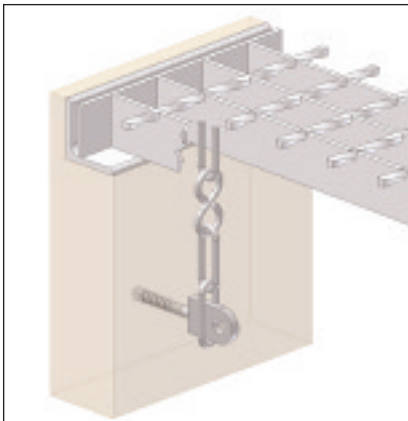

Safety chain / Fixing B 12.1

- Consisting of:
- safety chain, length 500 to 1000 mm
 - screw anchor including synthetic plug.

Safety chain / Fixing B 12.2

- Contrary to sketch, this fixing system is supplied for installation following location of gratings and consists of:
- 2 straps out of flat material placed above bearing bar,
 - 2 chains, length approx. 700 mm
 - 2 screw anchors.

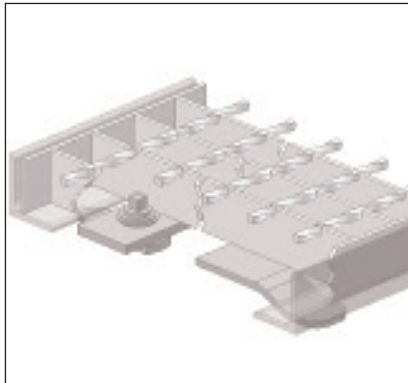

Socket spanner lock / fixing B 13.1 with square 7

Including facing brackets. Type B 13.1 available to use from above or beneath (sketch: lockable from above)

Socket spanner lock / fixing B 13.2 with square 8

Including facing brackets (also for heavy-duty gratings). This type can be supplied in galvanised steel or stainless steel

Socket spanner lock / fixing B 13.3 with square 8

Can be screwed to grating afterwards. Suitable for gratings with a pitch of 33,33 mm and heights of 25, 30 and 40 mm.



Special socket spanner B 14.1

with inside square for socket spanner lock no. 13.1 with square 7.

Special socket spanner B 14.2

with inside square for socket spanner lock no. 13.2 and 13.3 with square 8.

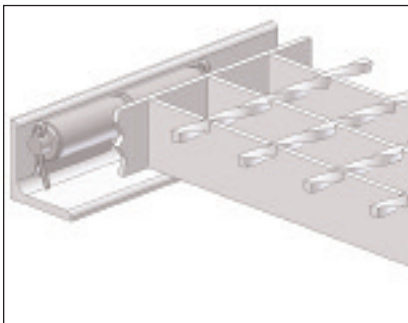

Hinge B 15

- Consisting of:
- 2 hinge flaps
 - 1 hinge bolt
 - U-plate
 - 2 split-pins.

A reinforced hinge will be used for gratings for vehicle traffic.

P Façade gratings

Lichtgitter façade gratings give life to the appearances of office buildings. Using gratings as decorative elements incorporated in complete architectural concepts are desirable design alternatives. Lichtgitter offers façade gratings in many colours and shapes. We offer a fitted façade grating for every requirement and project. Lichtgitter façade gratings form a modern and versatile construction element and fulfil various functions:

- **Sun protection** in order to avoid rays from direct sunlight. The sun protection effect depends on the height of the gratings, the pitch of the bars that run parallel to the façade and the angle of the sunlight.
- **Walkways** for window and façade cleaning as well as other exterior work.
- **Escape** routes in case of fire hazard and other emergency situations.
- **Decorative effect**
Façade gratings offer design alternatives for all types of modern architectural applications and create a decorative and interesting appearance. Façade gratings are resistant to corrosion because of specific pre-treatment. They require no maintenance, are economical and versatile.
For these reasons our gratings often form an essential element in building construction.
- **Simple erection**
Lichtgitter façade gratings can be stretched from cantilever to cantilever or from building to beam opposite. The distance between two cantilevers should ideally not exceed 2400 mm. This is to be considered during erection.



- **Types of façade gratings**
Façade gratings are mainly produced as pressure-locked gratings. They are made of aluminum or steel. Depending on the material, the surface finish can be anodised, galvanized, plastic-laminated, baked painted or self-coloured.

Lichtgitter ceiling patterns, in aluminum or other materials, offer an economical and decorative finish wherever halls, assembly rooms or other places of any size are decorated in a modern way. Lichtgitter ceiling patterns are distinguished by the following features:



- **Venting property:** Air can circulate unconstrained and the whole room can be ventilated and/or air-conditioned.
- **Light transmittance:** An optimal anti-glare room-illumination is achieved by an advantageous dispersion of all reflexions.
- **Dust:** Dirt cannot accumulate. Therefore, maintenance is not necessary.
- **Acoustic absorption:** Acoustic waves are broken and, therefore, noise levels are reduced.
- **Lightweight:** No overload of ceiling construction.
- **No electrostatic charging.**
- Lichtgitter ceiling patterns do not create any **fire hazard**.

- **Attractive shapes:** These provide many new interior design possibilities for architects.
- **Rich range of colours and surfaces:** Lichtgitter ceiling patterns can be supplied unfinished, coloured, anodised, baked painted or plastic-laminated in all RAL-colours.

Ceiling patterns can be used as insert ceilings with decorative and functional features in any room. They can be laid out seamlessly or endlessly one after another. When indirect anti-glare lighting is

required, lighting rows or other lamps can be placed above ceiling pattern.

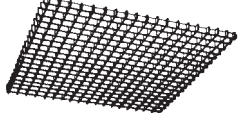
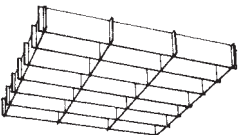
Cables and other supply pipes, heating, air conditioning and acoustic absorption equipment can be usefully installed between room ceiling and ceiling pattern. They are invisible, but easily accessible for repair or maintenance.

Types	Heights of bearing bars	Heights of cross bars	pitch
	30 mm	30 mm	ca. 33 x 33 mm
	60 mm	60 mm	ca. 33 x 66 mm
	60 mm	60 mm	ca. 66 x 66 mm

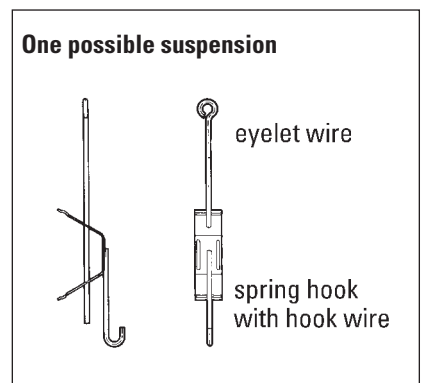
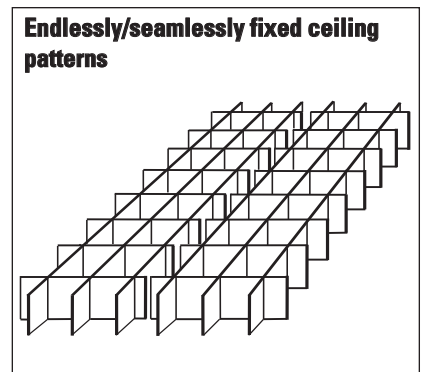

P Convector Covers

More and more new buildings, or modernised old buildings, are equipped with air conditioning or under floor heating. Radiators should either be covered to height of windowsill, or floor openings should be covered. These panels must look attractive, but should not incur any additional maintenance costs, let air flow freely, but avoid a direct view of the generally unattractive heating elements.

Our heating and ventilating gratings fulfil these requirements perfectly. Furthermore, they have the advantage of being tailor-made to any application.

Air flows, but view of the convector is prevented.

Panels and covers for radiators, heating and ventilation trunks should not only let air flow freely, but channel it in a specific direction. They are also expected to prevent direct view of the convector. Therefore, gratings with inclined cross bars are preferable. The standard pitch is 100 x 15 mm.

Convactor covers are made of aluminum or steel. Surfaces are finished according to the customer's choice.

Standard gratings can be used according to application.

Special types

Pressure-locked gratings as architectural applications in different forms and types are also part of the production programme. Fencings, decoration, elements for optical shelter and circulating air diffusers are examples of the wide range of applications. These pressure-locked gratings can be produced with cross bars angled at 45° as well as 15°.

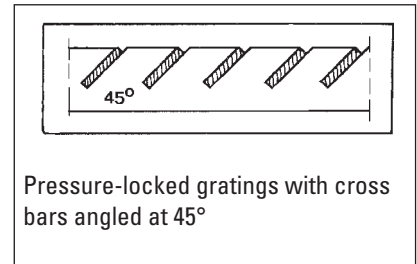

Example A:
Convactor cover with inclined cross bars. On request, we supply cross bars up to 1500 mm long for a grating size of not more than 0,8 m².

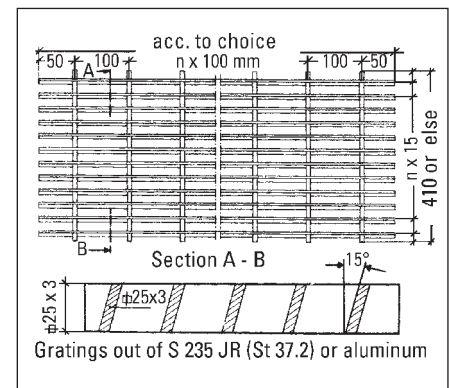

Example B:
Visual impression improved by raised cross bars.

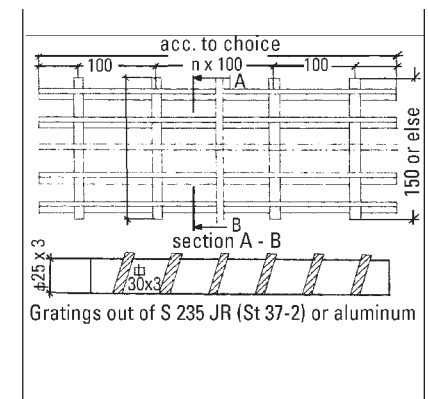

B Perforated Metal Planks

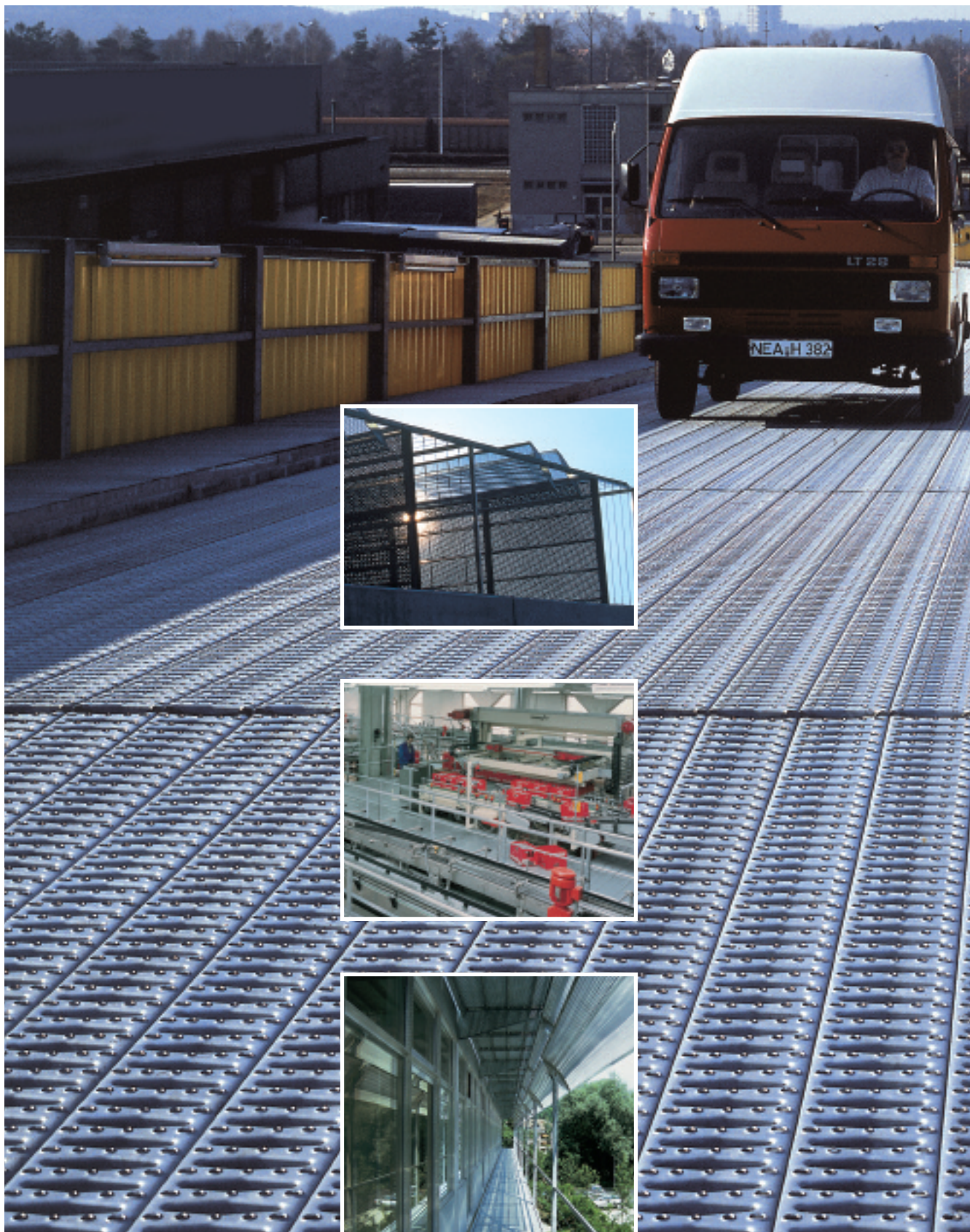

Perf. Metal Planks



Floor of an intermediate storage hall

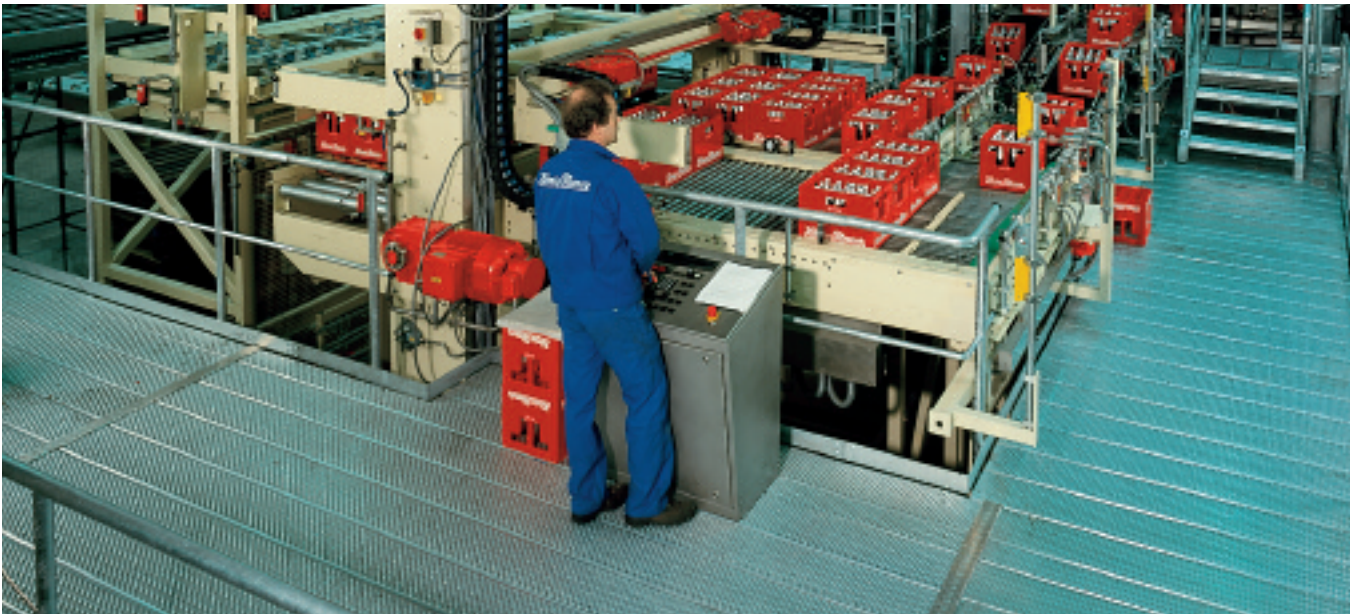

Working platform at a filling machine installation



Staircase with intermediate landing

B Perforated Metal Planks

Perforated metal planks for pedestrian traffic applications are the perfect complement to our long established and wellknown product range of industrial floorings. Perforated metal planks are cold-rolled to a channel profile and are produced by CNC-controlled punching and rolling machines.

Perforated metal planks distinguish themselves by providing a high level of slip resistance and secure step and standing areas, thereby increasing the overall level of safety in work areas. A high hydrostatic stability and ease of installation in particular, characterises these gratings. Large spans can be handled if properly sized, thus minimizing the use of substructures.

They are extensively used in all types of work platforms, car wash facilities, ramps, façades etc. Furthermore, they are employed for walkways and service areas as well as large-surfaced protection panels for working areas that are beneath conveying systems.



Stands in a soccer stadium

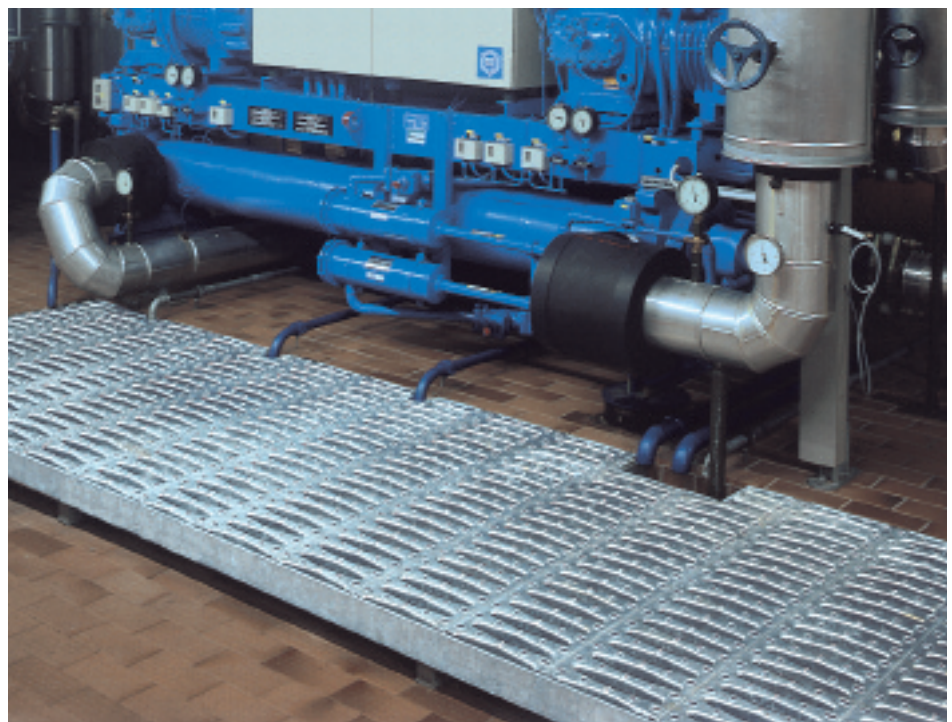

Work platform with perforated metal planks

B Perforated Metal Planks

Production

- Perforated metal planks are produced from coils in different materials.
- After an initial quality check has been carried out, coils are connected to CNC controlled production lines. Here the required product surfaces are punched and stamped out and the planks are then cut to size with the help of all relevant tooling.
- The indicated module „R“ (see note regarding different types) should be kept during determination of length. Of course, deviating dimensions are possible, but include extra work during production. The production length of galvanised elements should not exceed 6000 mm. Thickness and production lengths of planks are determined by the applied load and material requested.
- The punched planks are formed to a C-profile through a CNC controlled rolling technique.
- Necessary cutouts are made according to the data steered by a complete integrated data processing system.
- The cutouts are normally supplied complete with a binding bar, having the same height as the perforated metal plank.
- Perforated metal planks can be provided with welded kick flats, supplied in accordance with the requirements of DIN EN ISO 14122-3, where the upstand shall be at least 100 mm above the tread area.
- Galvanising according to German standard DIN EN ISO 1461 will be carried out at our galvanizing plant Verzinkerei Sulz GmbH, which is a member of the Lichtgitter group.
- Perforated metal planks can be supplied in lengths of 4000 mm, ex stock.



Sewage plant

BZ

Perforated metal planks, type BZ, offer a high degree of slip resistance due to their serrated surface. BZ gratings are used especially in areas where oil and grease would preclude the use of other gratings.

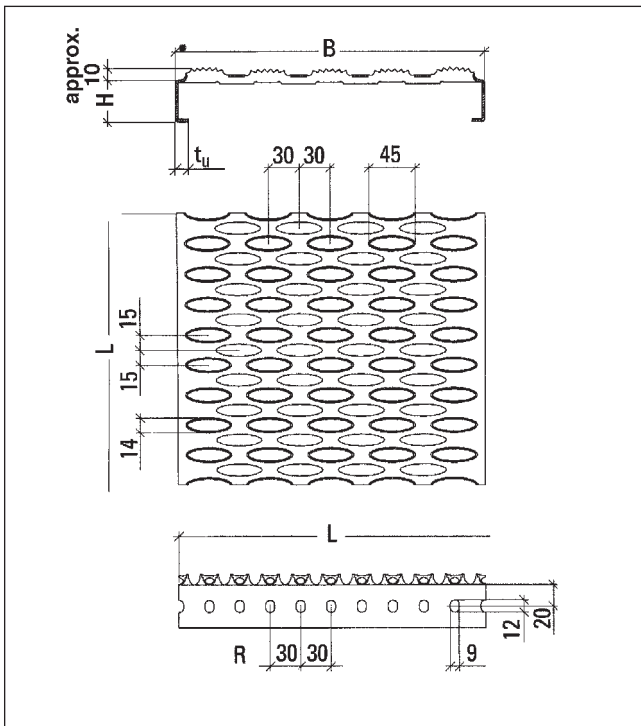
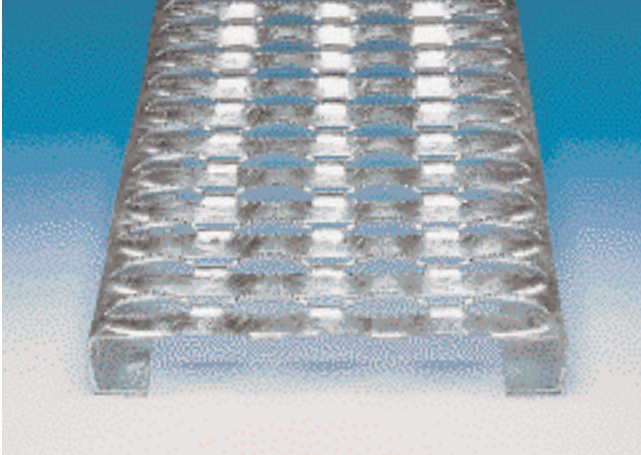

Perforated metal plank BZ	
Materials	Thickness of plank
Steel galvanised	2 and 2,5 mm
Stainless steel	1,5 and 2 mm
Aluminum	2 and 2,5 mm
Pre-treated	on request
Module R	30 mm
Standard length L	$n \times 30$; $n \times 30 + 15$; $n \times 30 - 15$
Width B	120, 180, 240, 300, 360, 420, 480 mm
Height H	40, 50, 75 mm
Rim t_u	at least 10 mm

BP

Perforated metal planks, type BP (parallel), are notable by their elegant appearance. Smooth routes and a high load bearing capacity mean that they are particularly suitable for large areas and industrial plants.

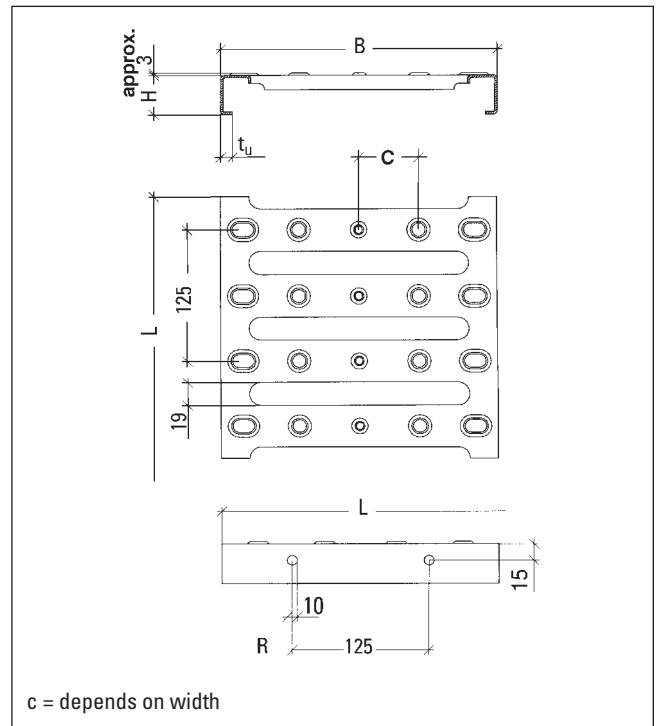

Perforated metal plank BP	
Materials	Thickness of plank
Steel galvanised	2 and 2,5 mm
Stainless steel	1,5 and 2 mm
Aluminum	2 and 2,5 mm
Pre-treated	on request
Module R	125 mm
Standard length L	preferably $n \times R$
Width B	150, 200, 250, 300, 400 mm
Height H	30, 50, 75, 100 mm
Rim t_u	at least 10 mm

Special types of all perforated metal planks on request.

BP-Ü

Perforated metal planks, type BP-Ü, offer an impressive level of slip resistance and load-carrying capacity.

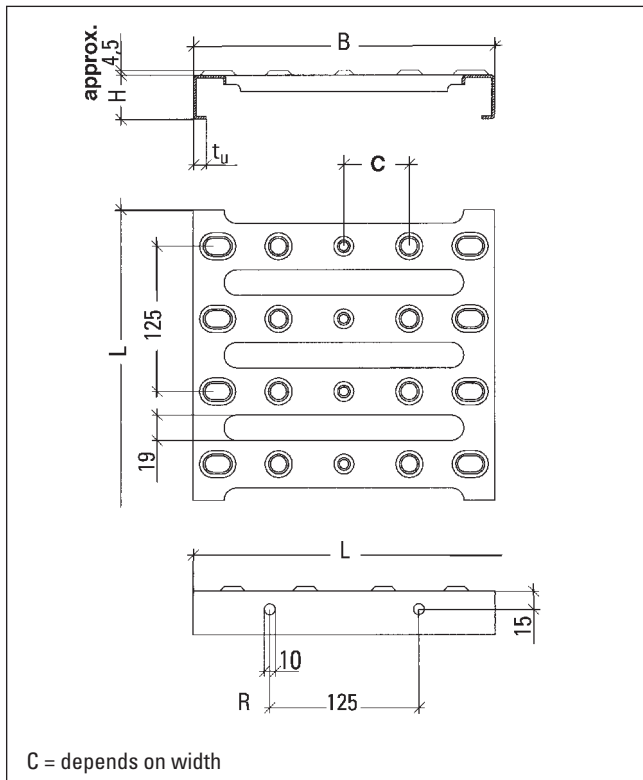
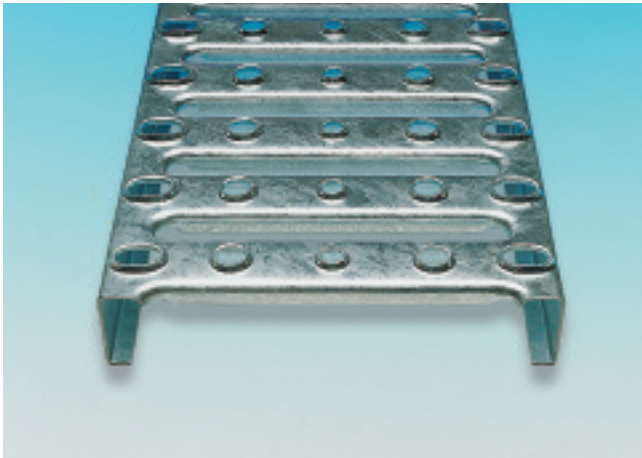

Perforated metal plank BP-Ü	
Materials	Thickness of plank
Steel galvanised	2 and 2,5 mm
Stainless steel	1,5 and 2 mm
Aluminum	2 and 2,5 mm
Pre-treated	on request
Module R	125 mm
Standard length L	preferably n x R
Width B	150, 200, 250, 300, 400 mm
Height H	50, 75, 100 mm
Rim t_u	at least 10 mm

BN-O

Perforated metal planks, type BN-O, offer pedestrians with normal shoes excellent levels of comfort, whilst maintaining high slip resistance. The unique punched hole pattern also ensures excellent drainage.

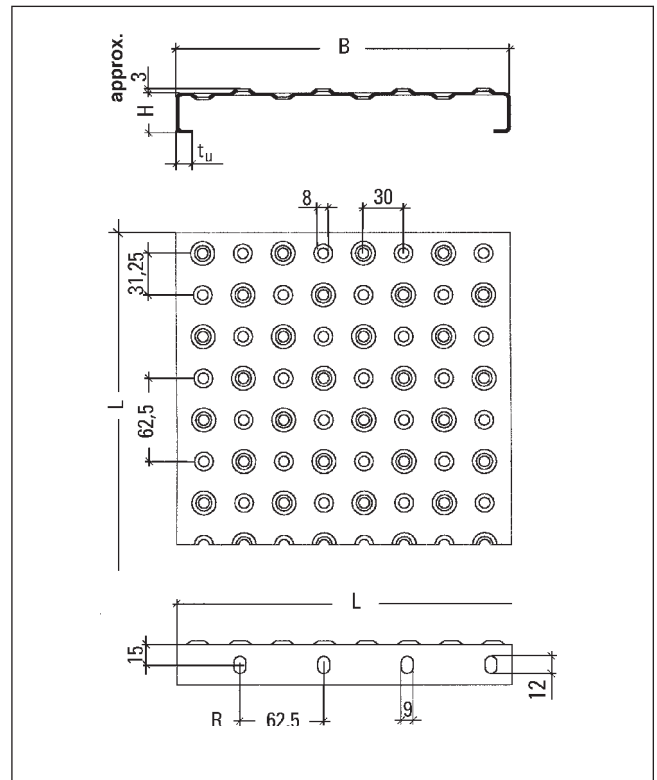
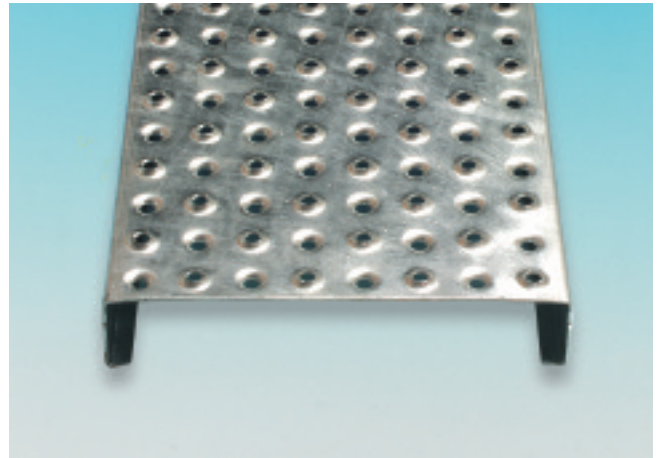

Perforated metal plank BN-O	
Materials	Thickness of plank
Steel galvanised	2 and 2,5 mm
Stainless steel	1,5 and 2 mm
Aluminum	2 and 2,5 mm
Pre-treated	on request
Module R	62,5 mm
Standard length L	preferably n x R
Width B	150, 200, 250, 300* mm
Height H	30, 50, 75, 100 mm
Rim t_u	at least 10 mm

We recommend using fixing no. 24 at intersection.
* take note of plank thickness

BN-G

Perforated metal planks, type BN-G, are used where there is no drainage issue. They are also suitable for pedestrian traffic.

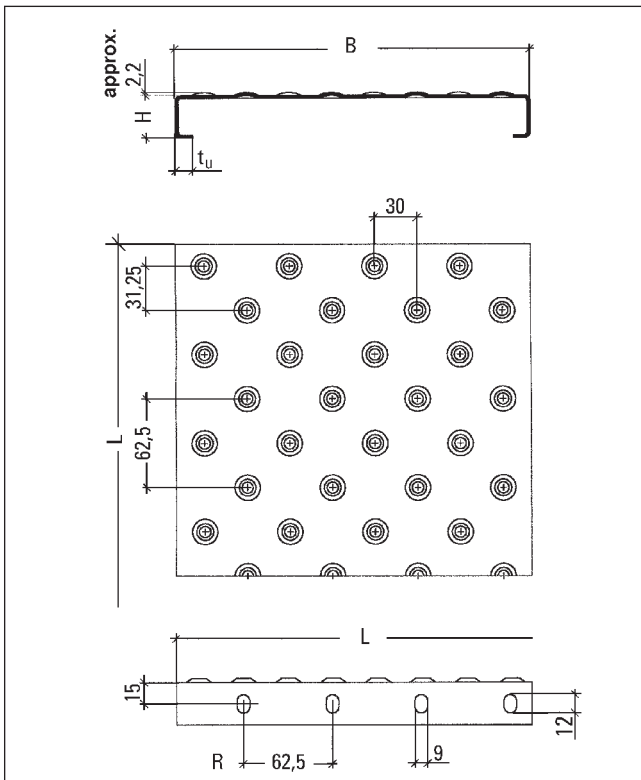
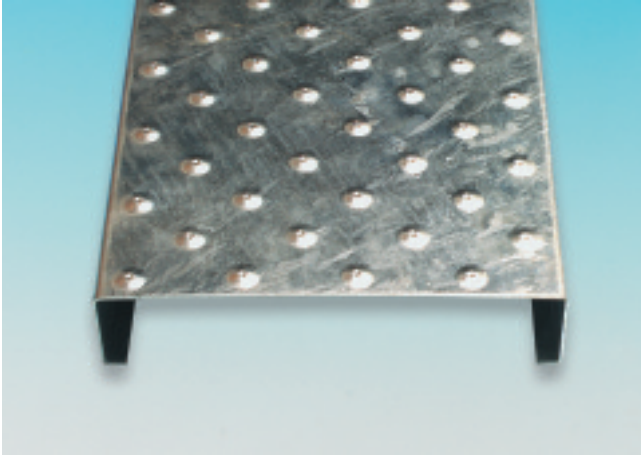

Perforated Metal Plank BN-G	
Materials	Thickness of plank
Steel galvanised	2 and 2,5 mm
Stainless steel	1,5 and 2 mm
Aluminum	2 and 2,5 mm
Pre-treated	on request
Module R	62,5 mm
Standard length L	preferably n x R
Width B	150, 200, 250, 300* mm
Height H	30, 50, 75, 100 mm
Rim t_u	at least 10 mm

We recommend using fixing no. 24 at intersection.

* take note of plank thickness

BR

Perforated metal planks, type BR, are particularly suitable for areas of concentrated loads on small contact areas (e.g. vehicle traffic).

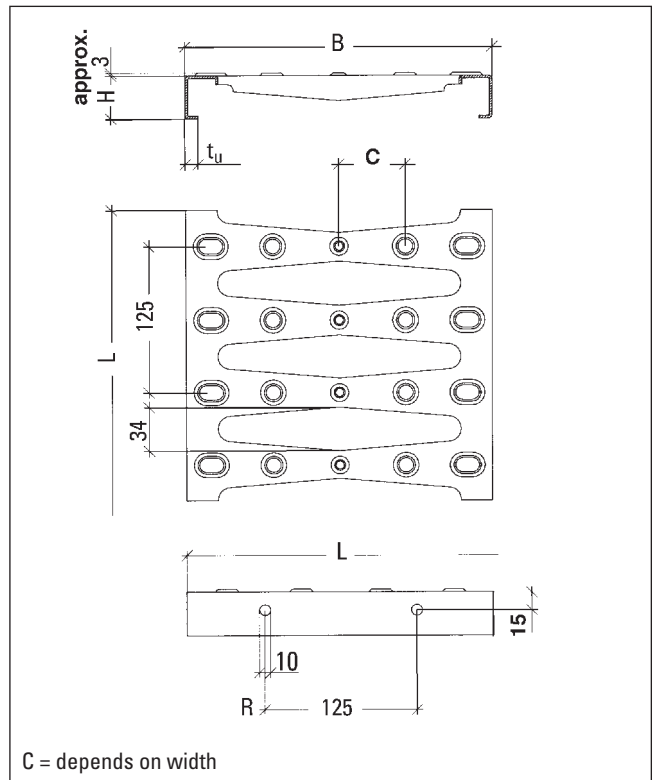
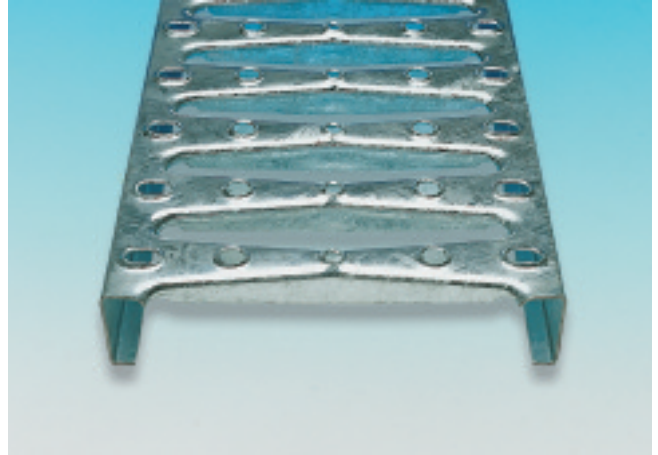

Perforated metal plank BR	
Materials	Thickness of plank
Steel galvanised	2 and 2,5 mm
Stainless steel	1,5 and 2 mm
Aluminum	2 and 2,5 mm
Pre-treated	on request
Module R	125 mm
Standard length L	preferable n x R
Width B	150, 200, 250 mm
Height H	30, 50, 75, 100 mm
Rim t_u	at least 10 mm

BP BR Load table

The table indicates the distributed load „F_v“ in kN/m² and the deflection „f“ in cm. Material S 235 JR (≙ St 37-2).

Type BP / BR	approx. gal. weight kg/m ²	load/ deflection	span in mm													
			500	600	700	800	900	1000	1100	1200	1300	1400	1500	1600	1700	
50 0	22,7	F _v	51,8	35,95	26,4	20,25	16	12,95	10,7	9	7,65	6,6	5,75	5,05	4,5	
		f	0,12	0,18	0,24	0,32	0,40	0,49	0,60	0,71	0,83	0,96	1,11	1,26	1,42	
150 / 50 / 2	27,2	F _v	112,95	78,4	57,6	44,1	34,85	28,25	23,35	19,6	16,7	14,4	12,55	11,05	9,75	
		f	0,08	0,11	0,15	0,19	0,24	0,30	0,36	0,43	0,51	0,59	0,68	0,77	0,87	
150 / 75 / 2	32,8	F _v	215,4	149,6	109,9	84,15	66,5	53,85	44,5	37,4	31,85	27,5	23,95	21,05	18,65	
		f	0,05	0,07	0,10	0,13	0,16	0,20	0,25	0,29	0,34	0,40	0,46	0,52	0,59	
150 / 100 / 2	38,3	F _v	346,5	240,65	176,8	135,35	106,95	86,65	71,6	60,15	51,25	44,2	38,5	33,85	29,95	
		f	0,04	0,06	0,08	0,10	0,12	0,15	0,19	0,22	0,26	0,30	0,35	0,39	0,44	
200 / 30 / 2	21,4	F _v	37,9	26,3	19,35	14,8	11,7	9,5	7,85	6,6	5,6	4,85	4,2	3,7	3,3	
		f	0,13	0,18	0,25	0,33	0,41	0,51	0,62	0,73	0,86	1,00	1,15	1,30	1,47	
200 / 50 / 2	24,8	F _v	82,7	57,4	42,2	32,3	25,5	20,65	17,1	14,35	12,25	10,55	9,2	8,05	7,15	
		f	0,08	0,11	0,15	0,20	0,25	0,31	0,37	0,44	0,52	0,61	0,69	0,79	0,89	
200 / 75 / 2	29,1	F _v	158,05	109,75	80,65	61,75	48,8	39,5	32,65	27,45	23,4	20,15	17,55	15,45	13,65	
		f	0,05	0,07	0,10	0,13	0,17	0,21	0,25	0,30	0,35	0,41	0,47	0,53	0,60	
200 / 100 / 2	33,2	F _v	254,8	176,95	130	99,55	78,65	63,7	52,65	44,25	37,7	32,5	28,3	24,9	22,05	
		f	0,04	0,06	0,08	0,10	0,13	0,16	0,19	0,22	0,26	0,31	0,35	0,40	0,45	
250 / 30 / 2	20,1	F _v	30,3	21,05	15,45	11,85	9,35	7,6	6,25	5,25	4,5	3,85	3,35	2,95	2,6	
		f	0,13	0,18	0,25	0,33	0,41	0,51	0,62	0,73	0,86	1,00	1,15	1,30	1,47	
250 / 50 / 2	22,8	F _v	66,15	45,95	33,75	25,85	20,4	16,55	13,65	11,5	9,8	8,45	7,35	6,45	5,7	
		f	0,08	0,11	0,15	0,20	0,25	0,31	0,37	0,44	0,52	0,61	0,69	0,79	0,89	
250 / 75 / 2	26,3	F _v	126,45	87,8	64,5	49,4	39	31,6	26,1	21,95	18,7	16,15	14,05	12,35	10,95	
		f	0,05	0,07	0,10	0,13	0,17	0,21	0,25	0,30	0,35	0,41	0,47	0,53	0,60	
250 / 100 / 2	29,6	F _v	203,85	141,55	104	79,6	62,9	50,95	42,1	35,4	30,15	26	22,65	19,9	17,65	
		f	0,04	0,06	0,08	0,10	0,13	0,16	0,19	0,22	0,26	0,31	0,35	0,40	0,45	
300 / 30 / 2	19,7	F _v	25,25	17,55	12,9	9,85	7,8	6,3	5,2	4,4	3,75	3,2	2,8	2,45	2,2	
		f	0,13	0,18	0,25	0,33	0,41	0,51	0,62	0,73	0,86	1,00	1,15	1,30	1,47	
300 / 50 / 2	21,9	F _v	55,1	38,3	28,1	21,55	17	13,8	11,4	9,55	8,15	7,05	6,1	5,4	4,75	
		f	0,08	0,11	0,15	0,20	0,25	0,31	0,37	0,44	0,52	0,61	0,69	0,79	0,89	
300 / 75 / 2	24,7	F _v	105,35	73,15	53,75	41,15	32,5	26,35	21,75	18,3	15,6	13,45	11,7	10,3	9,1	
		f	0,05	0,07	0,10	0,13	0,17	0,21	0,25	0,30	0,35	0,41	0,47	0,53	0,60	
300 / 100 / 2	27,5	F _v	169,85	117,95	86,65	66,35	52,45	42,45	35,1	29,5	25,15	21,65	18,85	16,6	14,7	
		f	0,04	0,06	0,08	0,10	0,13	0,16	0,19	0,22	0,26	0,31	0,35	0,40	0,45	
400 / 30 / 2	18,6	F _v	18,95	13,15	9,65	7,4	5,85	4,75	3,9	3,3	2,8	2,4	2,1			
		f	0,13	0,18	0,25	0,33	0,41	0,51	0,62	0,73	0,86	1,00	1,15			
400 / 50 / 2	20,3	F _v	41,35	28,7	21,1	16,15	12,75	10,35	8,55	7,2	6,1	5,25	4,6	4,05	3,6	
		f	0,08	0,11	0,15	0,20	0,25	0,31	0,37	0,44	0,52	0,61	0,69	0,79	0,89	
400 / 75 / 2	22,4	F _v	79	54,85	40,3	30,85	24,4	19,75	16,35	13,7	11,7	10,1	8,8	7,7	6,85	
		f	0,05	0,07	0,10	0,13	0,17	0,21	0,25	0,30	0,35	0,41	0,47	0,53	0,60	
400 / 100 / 2	24,5	F _v	127,4	88,5	65	49,75	39,3	31,85	26,3	22,1	18,85	16,25	14,15	12,45	11	
		f	0,04	0,06	0,08	0,10	0,13	0,16	0,19	0,22	0,26	0,31	0,35	0,40	0,45	

* = Key to symbols

F_v = uniformly distributed load (UDL)
in kN/m²

1kN = 1000 N = approx. 100 kg

f = deflection in cm at Last F_v

span in mm												
800	900	000	200	400	600	800	000	200	400	600	800	000
4	3,6	3,25	2,65	2,25								
1,60	1,78	1,97	2,38	2,84								
8,7	7,8	7,05	5,85	4,9	4,2	3,6	3,15	2,75	2,45	2,2		
0,98	1,09	1,20	1,46	1,73	2,03	2,36	2,71	3,08	3,48	3,90		
16,6	14,9	13,45	11,15	9,35	7,95	6,85	6	5,25	4,65	4,15	3,75	3,35
0,66	0,73	0,81	0,98	1,17	1,37	1,59	1,83	2,08	2,35	2,63	2,94	3,25
26,75	24	21,65	17,9	15,05	12,8	11,05	9,65	8,45	7,5	6,7	6	5,4
0,50	0,55	0,61	0,74	0,89	1,04	1,21	1,38	1,57	1,78	1,99	2,22	2,46
2,9	2,6	2,35										
1,65	1,84	2,04										
6,4	5,75	5,15	4,25	3,6	3,05	2,65	2,3	2				
1,00	1,11	1,23	1,49	1,78	2,09	2,42	2,78	3,16				
12,2	10,95	9,9	8,15	6,85	5,85	5,05	4,4	3,85	3,4	3,05	2,75	2,45
0,67	0,75	0,83	1,00	1,19	1,40	1,63	1,87	2,12	2,40	2,69	2,99	3,32
19,65	17,65	15,9	13,15	11,05	9,4	8,1	7,1	6,2	5,5	4,9	4,4	4
0,51	0,56	0,62	0,76	0,90	1,06	1,22	1,41	1,60	1,80	2,02	2,25	2,50
2,35	2,1											
1,65	1,84											
5,1	4,6	4,15	3,4	2,85	2,45	2,1						
1,00	1,11	1,23	1,49	1,78	2,09	2,42						
9,75	8,75	7,9	6,55	5,5	4,7	4,05	3,5	3,1	2,75	2,45	2,2	2
0,67	0,75	0,83	1,00	1,19	1,40	1,63	1,87	2,12	2,40	2,69	2,99	3,32
15,75	14,1	12,75	10,55	8,85	7,55	6,5	5,65	5	4,4	3,95	3,55	3,2
0,51	0,56	0,62	0,76	0,90	1,06	1,22	1,41	1,60	1,80	2,02	2,25	2,50
4,25	3,8	3,45	2,85	2,4	2,05							
1,00	1,11	1,23	1,49	1,78	2,09							
8,15	7,3	6,6	5,45	4,55	3,9	3,35	2,95	2,55	2,3	2,05		
0,67	0,75	0,83	1,00	1,19	1,40	1,63	1,87	2,12	2,40	2,69		
13,1	11,75	10,6	8,75	7,35	6,3	5,4	4,7	4,15	3,65	3,3	2,95	2,65
0,51	0,56	0,62	0,76	0,90	1,06	1,22	1,41	1,60	1,80	2,02	2,25	2,50
3,2	2,85	2,6	2,15									
1,00	1,11	1,23	1,49									
6,1	5,45	4,95	4,1	3,45	2,9	2,5	2,2					
0,67	0,75	0,83	1,00	1,19	1,40	1,63	1,87					
9,85	8,8	7,95	6,6	5,55	4,7	4,05	3,55	3,1	2,75	2,45	2,2	2
0,51	0,56	0,62	0,76	0,90	1,06	1,22	1,41	1,60	1,80	2,02	2,25	2,50

Larger spans are possible.

Data

Material stress (permissible tension):
16 kN/cm² (Material S235JR $\hat{=}$ St 37-2)

Safety factor to yield point: 1,5

Safety factor to breaking limit: 2,05

The **perforated metal plank support** should provide a bearing distance at each end of at least 25 mm. Deviations may be permitted, providing suitable measures are taken to prevent excessive movement away from the supports (see instruction sheet BDI 588).

Pedestrian traffic

Yellow: Perforated metal planks manufactured in accordance with the requirements of instruction sheet BGI 588 of the Berufsgenossenschaft professional association and to quality instructions RAL-GZ 639, are considered suitable for pedestrian traffic when they meet the following design criteria: The maximum permissible deflection 'f', does not exceed 1/200th of the span 'L' or 4 mm whichever is the lesser, under a concentrated load of 1,5 kN applied in the most unfavourable position, over a concentrated load area of 200 x 200 mm.

Green: The maximum permissible deflection 'f', does not exceed 1/200th of the span 'L', under a concentrated load of 1,5 kN applied in the most unfavourable position, over a concentrated load area of 200 x 200 mm.

Blue: The maximum permissible deflection 'f', does not exceed 1/200th of the span 'L', under a uniformly distributed load of 5 kN/m².

Multiplication factor for other materials

Material	load	deflection
Stainless steel 1.4301	0,82	0,84
Stainless steel 1.4571	0,88	0,90
Aluminum AlMg 3 G 22	0,54	1,61

BP BR Load table

The table indicates distributed load „F_v“ in kN/m² and the deflection „f“ in cm. Material S 235 JR (≈ St 37-2).

Type BP / BR	approx. gal. weight kg/m ²	load/ deflection	span in mm													
			500	600	700	800	900	1000	1100	1200	1300	1400	1500	1600	1700	
50 0 ,	28,8	F _v	61,3	42,55	31,25	23,95	18,9	15,3	12,65	10,65	9,05	7,8	6,8	6	5,3	
		f	0,12	0,18	0,24	0,32	0,40	0,49	0,60	0,71	0,83	0,96	1,11	1,26	1,42	
150 / 50 / 2,5	34,4	F _v	135,95	94,4	69,35	53,1	41,95	34	28,1	23,6	20,1	17,35	15,1	13,3	11,75	
		f	0,08	0,11	0,15	0,19	0,24	0,30	0,36	0,43	0,51	0,59	0,68	0,77	0,87	
150 / 75 / 2,5	41,4	F _v	261,9	181,85	133,6	102,3	80,85	65,45	54,1	45,45	38,75	33,4	29,1	25,55	22,65	
		f	0,05	0,07	0,10	0,13	0,16	0,20	0,25	0,29	0,34	0,40	0,46	0,52	0,59	
150 / 100 / 2,5	48,4	F _v	423,65	294,2	216,15	165,5	130,75	105,9	87,55	73,55	62,65	54,05	47,05	41,35	36,65	
		f	0,04	0,06	0,08	0,10	0,12	0,15	0,19	0,22	0,26	0,30	0,35	0,39	0,44	
200 / 30 / 2,5	27,1	F _v	44,8	31,1	22,85	17,5	13,85	11,2	9,25	7,8	6,65	5,7	5	4,4	3,9	
		f	0,13	0,18	0,25	0,33	0,41	0,51	0,62	0,73	0,86	1,00	1,15	1,30	1,47	
200 / 50 / 2,5	31,4	F _v	99,5	69,1	50,75	38,85	30,7	24,85	20,55	17,3	14,7	12,7	11,05	9,7	8,6	
		f	0,08	0,11	0,15	0,20	0,25	0,31	0,37	0,44	0,52	0,61	0,69	0,79	0,89	
200 / 75 / 2,5	36,6	F _v	192,05	133,35	98	75	59,25	48	39,7	33,35	28,4	24,5	21,35	18,75	16,6	
		f	0,05	0,07	0,10	0,13	0,17	0,21	0,25	0,30	0,35	0,41	0,47	0,53	0,60	
200 / 100 / 2,5	41,8	F _v	311,4	216,25	158,9	121,65	96,1	77,85	64,35	54,05	46,05	39,7	34,6	30,4	26,95	
		f	0,04	0,06	0,08	0,10	0,13	0,16	0,19	0,22	0,26	0,31	0,35	0,40	0,45	
250 / 30 / 2,5	25,6	F _v	35,85	24,9	18,3	14	11,05	8,95	7,4	6,2	5,3	4,55	4	3,5	3,1	
		f	0,13	0,18	0,25	0,33	0,41	0,51	0,62	0,73	0,86	1,00	1,15	1,30	1,47	
250 / 50 / 2,5	29,0	F _v	79,6	55,25	40,6	31,1	24,55	19,9	16,45	13,8	11,75	10,15	8,85	7,75	6,9	
		f	0,08	0,11	0,15	0,20	0,25	0,31	0,37	0,44	0,52	0,61	0,69	0,79	0,89	
250 / 75 / 2,5	33,2	F _v	153,65	106,7	78,4	60	47,4	38,4	31,75	26,65	22,75	19,6	17,05	15	13,3	
		f	0,05	0,07	0,10	0,13	0,17	0,21	0,25	0,30	0,35	0,41	0,47	0,53	0,60	
250 / 100 / 2,5	37,4	F _v	249,1	173	127,1	97,3	76,9	62,3	51,45	43,25	36,85	31,75	27,7	24,35	21,55	
		f	0,04	0,06	0,08	0,10	0,13	0,16	0,19	0,22	0,26	0,31	0,35	0,40	0,45	
300 / 30 / 2,5	24,9	F _v	29,9	20,75	15,25	11,65	9,2	7,45	6,15	5,2	4,4	3,8	3,3	2,9	2,6	
		f	0,13	0,18	0,25	0,33	0,41	0,51	0,62	0,73	0,86	1,00	1,15	1,30	1,47	
300 / 50 / 2,5	27,7	F _v	66,3	46,05	33,85	25,9	20,45	16,6	13,7	11,5	9,8	8,45	7,35	6,5	5,75	
		f	0,08	0,11	0,15	0,20	0,25	0,31	0,37	0,44	0,52	0,61	0,69	0,79	0,89	
300 / 75 / 2,5	31,2	F _v	128,05	88,9	65,3	50	39,5	32	26,45	22,25	18,95	16,35	14,25	12,5	11,1	
		f	0,05	0,07	0,10	0,13	0,17	0,21	0,25	0,30	0,35	0,41	0,47	0,53	0,60	
300 / 100 / 2,5	34,7	F _v	207,6	144,15	105,9	81,1	64,05	51,9	42,9	36,05	30,7	26,5	23,05	20,25	17,95	
		f	0,04	0,06	0,08	0,10	0,13	0,16	0,19	0,22	0,26	0,31	0,35	0,40	0,45	
400 / 30 / 2,5	23,5	F _v	22,4	15,55	11,45	8,75	6,9	5,6	4,65	3,9	3,3	2,85	2,5	2,2		
		f	0,13	0,18	0,25	0,33	0,41	0,51	0,62	0,73	0,86	1,00	1,15	1,30		
400 / 50 / 2,5	25,6	F _v	49,75	34,55	25,4	19,45	15,35	12,45	10,3	8,65	7,35	6,35	5,55	4,85	4,3	
		f	0,08	0,11	0,15	0,20	0,25	0,31	0,37	0,44	0,52	0,61	0,69	0,79	0,89	
400 / 75 / 2,5	28,3	F _v	96,05	66,7	49	37,5	29,65	24	19,85	16,65	14,2	12,25	10,65	9,4	8,3	
		f	0,05	0,07	0,10	0,13	0,17	0,21	0,25	0,30	0,35	0,41	0,47	0,53	0,60	

* = Key to symbols

F_v = uniformly distributed load (UDL)
in kN/m²

1 kN = 1000 N = approx. 100 kg

f = deflection in cm at load F_v

span in mm													
800	900	000	200	400	600	800	000	200	400	600	800	000	
4,75	4,25	3,85	3,15	2,65	2,25								
1,59	1,78	1,97	2,38	2,84	3,33								
10,5	9,4	8,5	7	5,9	5	4,35	3,8	3,3	2,95	2,6	2,35	2,1	
0,97	1,09	1,20	1,46	1,73	2,03	2,36	2,71	3,08	3,48	3,90	4,34	4,81	
20,2	18,15	16,35	13,55	11,35	9,7	8,35	7,25	6,4	5,65	5,05	4,55	4,1	
0,66	0,73	0,81	0,98	1,17	1,37	1,59	1,83	2,08	2,35	2,63	2,94	3,25	
32,7	29,35	26,5	21,9	18,4	15,65	13,5	11,75	10,35	9,15	8,15	7,35	6,6	
0,50	0,55	0,61	0,74	0,89	1,04	1,20	1,38	1,57	1,78	1,99	2,22	2,46	
3,45	3,1	2,8	2,3										
1,65	1,84	2,04	2,46										
7,7	6,9	6,2	5,15	4,3	3,7	3,15	2,75	2,45	2,15				
1,00	1,11	1,23	1,49	1,78	2,09	2,42	2,78	3,16	3,57				
14,8	13,3	12	9,9	8,35	7,1	6,1	5,35	4,7	4,15	3,7	3,3	3	
0,67	0,75	0,83	1,00	1,19	1,40	1,63	1,87	2,12	2,40	2,69	2,99	3,32	
24,05	21,55	19,45	16,1	13,5	11,5	9,95	8,65	7,6	6,75	6	5,4	4,85	
0,51	0,56	0,62	0,76	0,90	1,06	1,22	1,41	1,60	1,80	2,02	2,25	2,50	
2,75	2,5	2,25											
1,65	1,84	2,04											
6,15	5,5	4,95	4,1	3,45	2,95	2,55	2,2						
1,00	1,11	1,23	1,49	1,78	2,09	2,42	2,78						
11,85	10,65	9,6	7,95	6,65	5,7	4,9	4,25	3,75	3,3	2,95	2,65	2,4	
0,67	0,75	0,83	1,00	1,19	1,40	1,63	1,87	2,12	2,40	2,69	2,99	3,32	
19,2	17,25	15,55	12,85	10,8	9,2	7,95	6,9	6,1	5,4	4,8	4,3	3,9	
0,51	0,56	0,62	0,76	0,90	1,06	1,22	1,41	1,60	1,80	2,02	2,25	2,50	
2,3	2,05												
1,65	1,84												
5,1	4,6	4,15	3,45	2,9	2,45	2,1							
1,00	1,11	1,23	1,49	1,78	2,09	2,42							
9,9	8,85	8	6,6	5,55	4,75	4,1	3,55	3,15	2,75	2,45	2,2	2	
0,67	0,75	0,83	1,00	1,19	1,40	1,63	1,87	2,12	2,40	2,69	2,99	3,32	
16	14,4	12,95	10,7	9	7,7	6,6	5,75	5,05	4,5	4	3,6	3,25	
0,51	0,56	0,62	0,76	0,90	1,06	1,22	1,41	1,60	1,80	2,02	2,25	2,50	
3,85	3,45	3,1	2,55	2,15									
1,00	1,11	1,23	1,49	1,78									
7,4	6,65	6	4,95	4,15	3,55	3,05	2,65	2,35	2,1				
0,67	0,75	0,83	1,00	1,19	1,40	1,63	1,87	2,12	2,40				

Larger spans are possible.

Data

Material stress (permissible tension):
16 kN/cm² (Material S235JR $\hat{=}$ St 37-2)

Safety factor to yield point: 1,5

Safety factor to breaking limit: 2,05

The **perforated metal plank support** should provide a bearing distance at each end of at least 25 mm. Deviations may be permitted, providing suitable measures are taken to prevent excessive movement away from the supports (see instruction sheet BDI 588).

Pedestrian traffic

Yellow: Perforated metal planks manufactured in accordance with the requirements of instruction sheet BGI 588 of the Berufsgenossenschaft professional association and to quality instructions RAL-GZ 639, are considered suitable for pedestrian traffic when they meet the following design criteria: The maximum permissible deflection 'f', does not exceed 1/200th of the span 'L' or 4 mm whichever is the lesser, under a concentrated load of 1,5 kN applied in the most unfavourable position, over a concentrated load area of 200 x 200 mm.

Green: The maximum permissible deflection 'f', does not exceed 1/200th of the span 'L', under a concentrated load of 1,5 kN applied in the most unfavourable position, over a concentrated load area of 200 x 200 mm.

Blue: The maximum permissible deflection 'f', does not exceed 1/200th of the span 'L', under a uniformly distributed load of 5 kN/m².

Multiplication factor for other materials

Material		load	deflection
Stainless steel 1	4301	0,82	0,84
Stainless steel 1	4571	0,88	0,90
Aluminum AlMg 3	G 22	0,54	1,61

BN-G Load table

The table indicates distributed load „F_v“ in kN/m² and the deflection „f“ in cm . Material S 235 JR (≙ St 37-2).

Type BN-G	approx. gal. weight kg/m ²	load/ deflection	span in mm												
			500	600	700	800	900	1000	1100	1200	1300	1400	1500	1600	1700
50 0	24,6	F _v	62,95	43,7	32,1	24,6	19,4	15,75	13	10,95	9,3	8,05	7	6,15	5,45
		f	0,09	0,12	0,17	0,22	0,28	0,34	0,41	0,49	0,58	0,67	0,77	0,88	0,99
200 /30 / 2	22,7	F _v	48,05	33,35	24,5	18,75	14,85	12	9,95	8,35	7,1	6,15	5,35	4,7	4,15
		f	0,08	0,12	0,16	0,21	0,26	0,33	0,40	0,47	0,55	0,64	0,74	0,84	0,95
150 /50 / 2	29,2	F _v	142,5	98,95	72,7	55,65	44	35,65	29,45	24,75	21,1	18,2	15,85	13,9	12,35
		f	0,05	0,08	0,11	0,14	0,17	0,22	0,26	0,31	0,36	0,42	0,48	0,55	0,62
200 /50 / 2	26,1	F _v	109,65	76,15	55,95	42,85	33,85	27,4	22,65	19,05	16,2	14	12,2	10,7	9,5
		f	0,05	0,07	0,10	0,13	0,17	0,20	0,25	0,29	0,35	0,40	0,46	0,52	0,59
150 /75 / 2	34,7	F _v	277,2	192,5	141,45	108,3	85,55	69,3	57,25	48,15	41	35,35	30,8	27,05	24
		f	0,04	0,05	0,07	0,10	0,12	0,15	0,18	0,22	0,25	0,30	0,34	0,39	0,44
200 /75 / 2	30,3	F _v	214,9	149,25	109,65	83,95	66,35	53,75	44,4	37,3	31,8	27,4	23,9	21	18,6
		f	0,04	0,05	0,07	0,09	0,12	0,14	0,17	0,21	0,24	0,28	0,32	0,37	0,41
150 /100 / 2	40,3	F _v	448	311,1	228,55	175	138,25	112	92,55	77,8	66,25	57,15	49,8	43,75	38,75
		f	0,03	0,04	0,06	0,08	0,10	0,12	0,14	0,17	0,20	0,23	0,26	0,30	0,34
200 /100 / 2	34,5	F _v	349,15	242,45	178,15	136,4	107,75	87,3	72,15	60,6	51,65	44,55	38,8	34,1	30,2
		f	0,03	0,04	0,05	0,07	0,09	0,11	0,13	0,16	0,19	0,22	0,25	0,28	0,32
150 /30 / 2,5	30,8	F _v	74,95	52,05	38,25	29,3	23,15	18,75	15,5	13	11,1	9,55	8,35	7,3	6,5
		f	0,09	0,12	0,17	0,22	0,28	0,34	0,42	0,49	0,58	0,67	0,77	0,88	0,99
200 /30 / 2,5	28,3	F _v	57,25	39,75	29,2	22,35	17,7	14,3	11,85	9,95	8,45	7,3	6,35	5,6	4,95
		f	0,08	0,12	0,16	0,21	0,27	0,33	0,40	0,47	0,56	0,64	0,74	0,84	0,95
250 /30 / 2,5	26,8	F _v	46,35	32,2	23,65	18,1	14,3	11,6	9,6	8,05	6,85	5,9	5,15	4,55	4
		f	0,08	0,11	0,16	0,20	0,26	0,32	0,39	0,46	0,54	0,63	0,72	0,82	0,92
150 /50 / 2,5	36,4	F _v	172,4	119,75	87,95	67,35	53,2	43,1	35,6	29,95	25,5	22	19,15	16,85	14,9
		f	0,05	0,08	0,11	0,14	0,17	0,22	0,26	0,31	0,36	0,42	0,48	0,55	0,62
200 /50 / 2,5	32,5	F _v	132,7	92,15	67,7	51,85	40,95	33,2	27,4	23,05	19,65	16,95	14,75	12,95	11,5
		f	0,05	0,07	0,10	0,13	0,17	0,20	0,25	0,29	0,35	0,40	0,46	0,52	0,59
250 /50 / 2,5	30,2	F _v	108	75	55,1	42,2	33,35	27	22,3	18,75	16	13,8	12	10,55	9,35
		f	0,05	0,07	0,10	0,13	0,16	0,20	0,24	0,28	0,33	0,39	0,44	0,51	0,57
150 /75 / 2,5	43,4	F _v	338,4	235	172,65	132,2	104,45	84,6	69,9	58,75	50,05	43,15	37,6	33,05	29,3
		f	0,04	0,05	0,07	0,10	0,12	0,15	0,18	0,22	0,25	0,30	0,34	0,39	0,44
200 /75 / 2,5	37,8	F _v	262,45	182,25	133,9	102,5	81	65,6	54,25	45,55	38,8	33,5	29,15	25,65	22,7
		f	0,04	0,05	0,07	0,09	0,12	0,14	0,17	0,21	0,24	0,28	0,32	0,37	0,41
250 /75 / 2,5	34,4	F _v	214,75	149,1	109,55	83,9	66,25	53,7	44,35	37,3	31,75	27,4	23,85	20,95	18,6
		f	0,03	0,05	0,07	0,09	0,11	0,14	0,17	0,20	0,23	0,27	0,31	0,35	0,40
150 /100 / 2,5	50,4	F _v	549,65	381,7	280,4	214,7	169,65	137,4	113,55	95,4	81,3	70,1	61,05	53,65	47,55
		f	0,03	0,04	0,06	0,08	0,10	0,12	0,14	0,17	0,20	0,23	0,26	0,30	0,34
200 /100 / 2,5	43,1	F _v	428,5	297,55	218,6	167,4	132,25	107,1	88,55	74,4	63,4	54,65	47,6	41,85	37,05
		f	0,03	0,04	0,05	0,07	0,09	0,11	0,13	0,16	0,19	0,22	0,25	0,28	0,32
250 /100 / 2,5	38,6	F _v	352,05	244,5	179,6	137,5	108,65	88	72,75	61,1	52,1	44,9	39,1	34,4	30,45
		f	0,03	0,04	0,05	0,07	0,09	0,11	0,13	0,15	0,18	0,21	0,24	0,27	0,31

* = Key to symbols

F_v = uniformly distributed load (UDL)
in kN/m²

1 kN = 1000 N = approx. 100 kg

f = deflection in cm at load F_v

span in mm												
800	900	000	200	400	600	800	000	200	400	600	800	000
4,85	4,35	3,95	3,25	2,75	2,35	2						
1,11	1,24	1,37	1,66	1,97	2,31	2,68						
3,7	3,35	3	2,5	2,1								
1,06	1,18	1,31	1,58	1,88								
11	9,85	8,9	7,35	6,2	5,25	4,55	3,95	3,5	3,1	2,75	2,45	2,25
0,70	0,78	0,86	1,04	1,24	1,45	1,69	1,94	2,20	2,49	2,79	3,11	3,44
8,45	7,6	6,85	5,65	4,75	4,05	3,5	3,05	2,7	2,35	2,1		
0,66	0,74	0,82	0,99	1,18	1,38	1,60	1,84	2,09	2,36	2,65		
21,4	19,2	17,35	14,3	12,05	10,25	8,85	7,7	6,75	6	5,35	4,8	4,35
0,49	0,54	0,60	0,73	0,87	1,02	1,18	1,36	1,54	1,74	1,95	2,17	2,41
16,6	14,9	13,45	11,1	9,35	7,95	6,85	6	5,25	4,65	4,15	3,7	3,35
0,46	0,51	0,57	0,69	0,82	0,96	1,12	1,28	1,46	1,65	1,85	2,06	2,28
34,55	31	28	23,15	19,45	16,55	14,3	12,45	10,95	9,7	8,65	7,75	7
0,38	0,42	0,47	0,57	0,68	0,79	0,92	1,06	1,20	1,36	1,52	1,70	1,88
26,95	24,2	21,8	18,05	15,15	12,9	11,15	9,7	8,5	7,55	6,75	6,05	5,45
0,36	0,40	0,44	0,54	0,64	0,75	0,87	1,00	1,14	1,28	1,44	1,60	1,78
5,8	5,2	4,7	3,85	3,25	2,75	2,4	2,1					
1,11	1,24	1,37	1,66	1,98	2,32	2,69	3,09					
4,4	3,95	3,6	2,95	2,5	2,1							
1,06	1,19	1,31	1,59	1,89	2,22							
3,6	3,2	2,9	2,4	2								
1,03	1,15	1,28	1,54	1,84								
13,3	11,95	10,8	8,9	7,5	6,4	5,5	4,8	4,2	3,75	3,35	3	2,7
0,70	0,78	0,86	1,04	1,24	1,45	1,69	1,94	2,20	2,49	2,79	3,11	3,44
10,25	9,2	8,3	6,85	5,75	4,9	4,25	3,7	3,25	2,85	2,55	2,3	2,05
0,66	0,74	0,82	0,99	1,18	1,38	1,60	1,84	2,10	2,37	2,65	2,95	3,27
8,35	7,5	6,75	5,6	4,7	4	3,45	3	2,65	2,35	2,1		
0,64	0,71	0,79	0,96	1,14	1,34	1,55	1,78	2,02	2,28	2,56		
26,1	23,45	21,15	17,5	14,7	12,5	10,8	9,4	8,25	7,3	6,55	5,85	5,3
0,49	0,54	0,60	0,73	0,87	1,02	1,18	1,36	1,54	1,74	1,95	2,17	2,41
20,25	18,2	16,4	13,55	11,4	9,7	8,35	7,3	6,4	5,7	5,05	4,55	4,1
0,46	0,52	0,57	0,69	0,82	0,96	1,12	1,28	1,46	1,65	1,85	2,06	2,28
16,55	14,85	13,4	11,1	9,3	7,95	6,85	5,95	5,25	4,65	4,15	3,7	3,35
0,44	0,50	0,55	0,66	0,79	0,93	1,08	1,24	1,41	1,59	1,78	1,98	2,20
42,4	38,05	34,35	28,4	23,85	20,35	17,55	15,25	13,4	11,9	10,6	9,5	8,6
0,38	0,42	0,47	0,57	0,68	0,79	0,92	1,06	1,20	1,36	1,52	1,70	1,88
33,05	29,65	26,8	22,15	18,6	15,85	13,65	11,9	10,45	9,25	8,25	7,4	6,7
0,36	0,40	0,44	0,54	0,64	0,75	0,87	1,00	1,14	1,28	1,44	1,61	1,78
27,15	24,4	22	18,2	15,3	13	11,25	9,8	8,6	7,6	6,8	6,1	5,5
0,35	0,39	0,43	0,52	0,61	0,72	0,84	0,96	1,09	1,23	1,38	1,54	1,71

Larger spans are possible

Data

Material stress (permissible tension):
16 kN/cm² (Material S235JR $\hat{=}$ St 37-2)

Safety factor to yield point: 1,5

Safety factor to breaking limit: 2,05

The **perforated metal plank support** should provide a bearing distance at each end of at least 25 mm. Deviations may be permitted, providing suitable measures are taken to prevent excessive movement away from the supports (see instruction sheet BDI 588).

Pedestrian traffic

Yellow: Perforated metal planks manufactured in accordance with the requirements of instruction sheet BGI 588 of the Berufsgenossenschaft professional association and to quality instructions RAL-GZ 639, are considered suitable for pedestrian traffic when they meet the following design criteria: The maximum permissible deflection 'f', does not exceed 1/200th of the span 'L' or 4 mm whichever is the lesser, under a concentrated load of 1,5 kN applied in the most unfavourable position, over a concentrated load area of 200 x 200 mm.

Green: The maximum permissible deflection 'f', does not exceed 1/200th of the span 'L', under a concentrated load of 1,5 kN applied in the most unfavourable position, over a concentrated load area of 200 x 200 mm.

Blue: The maximum permissible deflection 'f', does not exceed 1/200th of the span 'L', under a uniformly distributed load of 5 kN/m².

Multiplication factor for other materials

Material		load	deflection
Stainless steel 1	4301	0,82	0,84
Stainless steel 1	4571	0,88	0,90
Aluminum AlMg3	G 22	0,54	1,61

Multiplication factor for type BN-O

The appropriate loads may be determined by using multiplication factors ranging between 0,86 (for 150/30/2) and 0,73 (for 250/100/3) depending on the plank type considered. The corresponding deflections under load may be determined by using multiplication factors ranging between 1,34 and 1,41.

BZ Loadtable

The table indicates **distributed load** „F_v“ in kN/m² and the deflection „f“ in cm. Material S 235 JR (≅ ST 37-2).

Type BZ	approx. gal. weight kg/m ²	load/ deflection	span in mm												
			500	600	700	800	900	1000	1100	1200	1300	1400	1500	1600	1700
20 0	23,9	F _v	80,7	56,1	41,2	31,5	24,9	20,2	16,7	14	11,9	10,3	9	7,9	7
		f	0,09	0,14	0,18	0,24	0,31	0,38	0,46	0,54	0,64	0,74	0,85	0,96	1,09
180 /40 /2	20,7	F _v	53,8	37,4	27,5	21	16,6	13,5	11,1	9,3	8	6,9	6	5,3	4,7
		f	0,09	0,14	0,18	0,24	0,31	0,38	0,46	0,54	0,64	0,74	0,85	0,96	1,09
240 /40 /2	19,2	F _v	40,4	28	20,6	15,8	12,5	10,1	8,3	7	6	5,15	4,5	3,9	3,5
		f	0,09	0,14	0,18	0,24	0,31	0,38	0,46	0,54	0,64	0,74	0,85	0,96	1,09
300 /40 /2	18,1	F _v	32,3	22,4	16,5	12,6	10	8,1	6,7	5,6	4,8	4,1	3,6	3,15	2,8
		f	0,09	0,14	0,18	0,24	0,31	0,38	0,46	0,54	0,64	0,74	0,85	0,96	1,09
360 /40 /2	17,5	F _v	26,9	18,7	13,7	10,5	8,3	6,7	5,6	4,7	4	3,4	3	2,6	2,3
		f	0,09	0,14	0,18	0,24	0,31	0,38	0,46	0,54	0,64	0,74	0,85	0,96	1,09
420 /40 /2	17,1	F _v	23,1	16	11,8	9	7,1	5,8	4,8	4	3,4	2,9	2,6	2,25	2
		f	0,09	0,14	0,18	0,24	0,31	0,38	0,46	0,54	0,64	0,74	0,85	0,96	1,09
480 /40 /2	16,7	F _v	20,2	14	10,3	7,9	6,2	5,05	4,2	3,5	3	2,6	2,2	2	1,75
		f	0,09	0,14	0,18	0,24	0,31	0,38	0,46	0,54	0,64	0,74	0,85	0,96	1,09
120 /50 /2	26,7	F _v	116,4	80,8	59,4	45,5	35,9	29,1	24	20,2	17,2	14,8	12,9	11,4	10,1
		f	0,08	0,11	0,15	0,19	0,25	0,30	0,37	0,44	0,51	0,60	0,68	0,78	0,88
180 /50 /2	22,6	F _v	77,6	53,9	39,6	30,3	23,95	19,4	16	13,5	11,5	9,9	8,6	7,6	6,7
		f	0,08	0,11	0,15	0,19	0,25	0,30	0,37	0,44	0,51	0,60	0,68	0,78	0,88
240 /50 /2	20,6	F _v	58,2	40,4	29,7	22,7	18	14,55	12	10,1	8,6	7,4	6,5	5,7	5
		f	0,08	0,11	0,15	0,19	0,25	0,30	0,37	0,44	0,51	0,60	0,68	0,78	0,88
300 /50 /2	19,2	F _v	46,55	32,3	23,75	18,2	14,4	11,6	9,6	8,1	6,9	5,9	5,2	4,55	4
		f	0,08	0,11	0,15	0,19	0,25	0,30	0,37	0,44	0,51	0,60	0,68	0,78	0,88
360 /50 /2	18,5	F _v	38,8	26,9	19,8	15,15	12	9,7	8	6,7	5,7	4,95	4,3	3,8	3,4
		f	0,08	0,11	0,15	0,19	0,25	0,30	0,37	0,44	0,51	0,60	0,68	0,78	0,88
420 /50 /2	17,9	F _v	33,25	23,1	17	13	10,3	8,3	6,9	5,8	4,9	4,2	3,7	3,25	2,9
		f	0,08	0,11	0,15	0,19	0,25	0,30	0,37	0,44	0,51	0,60	0,68	0,78	0,88
480 /50 /2	17,4	F _v	29,1	20,2	14,8	11,4	9	7,3	6	5,05	4,3	3,7	3,2	2,8	2,5
		f	0,08	0,11	0,15	0,19	0,25	0,30	0,37	0,44	0,51	0,60	0,68	0,78	0,88
120 /75 /2	33,8	F _v	230,6	160,1	117,6	90,1	71,2	57,6	47,6	4	34,1	29,4	25,6	22,5	19,95
		f	0,05	0,07	0,10	0,13	0,17	0,20	0,25	0,29	0,35	0,40	0,46	0,52	0,59
180 /75 /2	27,3	F _v	153,7	106,75	78,4	60	47,4	38,4	31,8	26,7	22,7	19,6	17,1	15	13,3
		f	0,05	0,07	0,10	0,13	0,17	0,20	0,25	0,29	0,35	0,40	0,46	0,52	0,59
240 /75 /2	24,1	F _v	115,3	80	58,8	45	35,6	38,8	23,8	20	17,05	14,7	12,8	11,3	10
		f	0,05	0,07	0,10	0,13	0,17	0,20	0,25	0,29	0,35	0,40	0,46	0,52	0,59
300 /75 /2	22,1	F _v	92,2	64,05	47,1	36	28,5	23,1	19,1	16	13,6	11,8	10,25	9	8
		f	0,05	0,07	0,10	0,13	0,17	0,20	0,25	0,29	0,35	0,40	0,46	0,52	0,59
360 /75 /2	20,8	F _v	76,9	53,4	39,2	30	23,7	19,2	15,9	13,3	11,4	9,8	8,5	7,5	6,65
		f	0,05	0,07	0,10	0,13	0,17	0,20	0,25	0,29	0,35	0,40	0,46	0,52	0,59
420 /75 /2	19,9	F _v	65,9	45,75	33,6	23,7	20,3	16,5	13,6	11,4	9,75	8,4	7,3	6,4	5,7
		f	0,05	0,07	0,10	0,13	0,17	0,20	0,25	0,29	0,35	0,40	0,46	0,52	0,59
480 /75 /2	19,1	F _v	57,6	40	29,4	22,5	17,8	14,4	11,9	10	8,5	7,35	6,4	5,6	5
		f	0,05	0,07	0,10	0,13	0,17	0,20	0,25	0,29	0,35	0,40	0,46	0,52	0,59

*** = Key to symbols**

F_v = uniformly distributed load (UDL) in kN/m²

1 kN = 1000 N = approx. 100 kg

f = deflection in cm at load F_v

span in mm													
800	900	000	200	400	600	800	000	200	400	600	800	000	000
6,2	5,6	5,05	4,2	3,5	3	2,6	2,2	2	1,75				
1,22	1,36	1,51	1,82	2,17	2,55	2,95	3,39	3,86	4,35				
4,15	3,7	3,4	2,8	2,3	2	1,7							
1,22	1,36	1,51	1,82	2,17	2,55	2,95							
3,1	2,8	2,5	2,1	1,75									
1,22	1,36	1,51	1,82	2,17									
2,5	2,2	2											
1,22	1,36	1,51											
2,1	1,9												
1,22	1,36												
1,8													
1,22													
9	8,1	7,3	6	5,05	4,3	3,7	3,2	2,8	2,5	2,2	2	1,8	
0,98	1,10	1,21	1,47	1,75	2,05	2,38	2,73	3,11	3,51	3,93	4,38	4,86	
6	5,4	4,85	4	3,4	2,9	2,5	2,2	1,9					
0,98	1,10	1,21	1,47	1,75	2,05	2,38	2,73	3,11					
4,5	4	3,6	3	2,5	2,15	1,9	1,6						
0,98	1,10	1,21	1,47	1,75	2,05	2,38	2,73						
3,6	3,2	2,9	2,4	2	1,7								
0,98	1,10	1,21	1,47	1,75	2,05								
3	2,7	2,4	2										
0,98	1,10	1,21	1,47										
2,6	2,3	2,1	1,7										
0,98	1,10	1,21	1,47										
2,2	2	1,8											
0,98	1,10	1,21											
17,8	16	14,4	11,9	10	8,5	7,35	6,4	5,6	5	4,45	4	3,6	
0,66	0,74	0,82	0,99	1,18	1,38	1,61	1,84	2,10	2,37	2,65	2,96	3,28	
11,9	10,6	9,6	7,9	6,7	5,7	4,9	4,3	3,75	3,3	3	2,7	2,4	
0,66	0,74	0,82	0,99	1,18	1,38	1,61	1,84	2,10	2,37	2,65	2,96	3,28	
8,9	8	7,2	5,95	5	4,3	3,7	3,2	2,8	2,5	2,2	2	1,8	
0,66	0,74	0,82	0,99	1,18	1,38	1,61	1,84	2,10	2,37	2,65	2,96	3,28	
7,1	6,4	5,8	4,8	4	3,4	2,9	2,6	2,25	2	1,8			
0,66	0,74	0,82	0,99	1,18	1,38	1,61	1,84	2,10	2,37	2,65			
5,9	5,3	4,8	4	3,3	2,8	2,45	2,1	1,9					
0,66	0,74	0,82	0,99	1,18	1,38	1,61	1,84	2,10					
5,1	4,6	4,1	3,4	2,9	2,4	2,1	1,8						
0,66	0,74	0,82	0,99	1,18	1,38	1,61	1,84						
4,45	4	3,6	3	2,5	2,1	1,8							
0,66	0,74	0,82	0,99	1,18	1,38	1,61							

Larger spans are possible.

Data

Material stress (permissible tension):
16 kN/cm² (Material S235JR ≙ St 37-2)

Safety factor to yield point: 1,5

Safety factor to breaking point: 2,05

The **perforated metal plank support** should provide a bearing distance at each end of at least 25 mm. Deviations may be permitted, providing suitable measures are taken to prevent excessive movement away from the supports (see instruction sheet BDI 588).

Pedestrian traffic

Yellow: Perforated metal planks manufactured in accordance with the requirements of instruction sheet BGI 588 of the Berufsgenossenschaft professional association and to quality instructions RAL-GZ 639, are considered suitable for pedestrian traffic when they meet the following design criteria: The maximum permissible deflection 'f', does not exceed 1/200th of the span 'L' or 4 mm whichever is the lesser, under a concentrated load of 1,5 kN applied in the most unfavourable position, over a concentrated load area of 200 x 200 mm.

Green: The maximum permissible deflection 'f', does not exceed 1/200th of the span 'L', under a concentrated load of 1,5 kN applied in the most unfavourable position, over a concentrated load area of 200 x 200 mm.

Blue: The maximum permissible deflection 'f', does not exceed 1/200th of the span 'L', under a uniformly distributed load of 5 kN/m².

Multiplication factor for other materials

Material	load	deflection
Stainless steel 1.4301	0,82	0,84
Stainless steel 1.4571	0,88	0,90
Aluminum AlMg 3 G 22	0,54	1,61

BZ Loadtable

The table indicates distributed load „F_v“ in kN/m² and the deflection „f“ in cm. Material S 235 JR (≈ St 37-2).

Type BZ	approx. gal. weight kg/m ²	load/ deflection	span in mm												
			500	600	700	800	900	1000	1100	1200	1300	1400	1500	1600	1700
20 0 ,	29,9	F _v	96,1	66,7	49	37,5	29,7	24	19,9	16,7	14,2	12,3	10,7	9,4	8,3
		f	0,09	0,14	0,18	0,24	0,30	0,38	0,46	0,54	0,64	0,74	0,85	0,96	1,09
180 / 40 / 2,5	25,3	F _v	64,1	44,5	32,7	25	19,8	16	13,2	11,1	9,5	8,2	7,1	6,3	5,5
		f	0,09	0,14	0,18	0,24	0,30	0,38	0,46	0,54	0,64	0,74	0,85	0,96	1,09
240 / 40 / 2,5	23,8	F _v	48,05	33,4	24,5	18,8	14,8	12	9,9	8,3	7,1	6,1	5,3	4,7	4,2
		f	0,09	0,14	0,18	0,24	0,30	0,38	0,46	0,54	0,64	0,74	0,85	0,96	1,09
300 / 40 / 2,5	22,4	F _v	38,4	26,7	19,6	15	11,9	9,6	7,9	6,7	5,7	4,9	4,3	3,75	3,3
		f	0,09	0,14	0,18	0,24	0,30	0,38	0,46	0,54	0,64	0,74	0,85	0,96	1,09
360 / 40 / 2,5	20	F _v	32	22,25	16,3	12,5	9,9	8	6,6	5,6	4,7	4,1	3,6	3,1	2,8
		f	0,09	0,14	0,18	0,24	0,30	0,38	0,46	0,54	0,64	0,74	0,85	0,96	1,09
420 / 40 / 2,5	22,4	F _v	27,5	19,1	14	10,7	8,5	6,9	5,7	4,8	4,1	3,5	3,05	2,7	2,4
		f	0,09	0,14	0,18	0,24	0,30	0,38	0,46	0,54	0,64	0,74	0,85	0,96	1,09
480 / 40 / 2,5	20,7	F _v	24	16,7	12,3	9,4	7,4	6	5	4,2	3,55	3,1	2,7	2,35	2,1
		f	0,09	0,14	0,18	0,24	0,30	0,38	0,46	0,54	0,64	0,74	0,85	0,96	1,09
120 / 50 / 2,5	33,4	F _v	139,6	96,9	71,2	54,5	43,1	34,9	28,8	24,2	20,65	17,8	15,5	13,6	12,1
		f	0,08	0,11	0,15	0,19	0,25	0,30	0,37	0,44	0,51	0,59	0,68	0,78	0,88
180 / 50 / 2,5	27,6	F _v	93,1	64,6	47,5	36,35	28,7	23,3	19,2	16,2	13,8	11,9	10,3	9,1	8,05
		f	0,08	0,11	0,15	0,19	0,25	0,30	0,37	0,44	0,51	0,59	0,68	0,78	0,88
240 / 50 / 2,5	25,6	F _v	69,8	48,5	35,6	27,3	21,5	17,45	14,4	12,1	10,3	8,9	7,75	6,8	6
		f	0,08	0,11	0,15	0,19	0,25	0,30	0,37	0,44	0,51	0,59	0,68	0,78	0,88
300 / 50 / 2,5	23,7	F _v	55,8	38,8	28,5	21,8	17,2	14	11,5	9,7	8,3	7,1	6,2	5,45	4,8
		f	0,08	0,11	0,15	0,19	0,25	0,30	0,37	0,44	0,51	0,59	0,68	0,78	0,88
360 / 50 / 2,5	21,3	F _v	46,5	32,3	23,7	18,2	14,4	11,6	9,6	8,1	6,9	5,9	5,2	4,5	4
		f	0,08	0,11	0,15	0,19	0,25	0,30	0,37	0,44	0,51	0,59	0,68	0,78	0,88
420 / 50 / 2,5	23,4	F _v	39,9	27,7	20,35	15,6	12,3	10	8,2	6,9	5,9	5,1	4,4	3,9	3,45
		f	0,08	0,11	0,15	0,19	0,25	0,30	0,37	0,44	0,51	0,59	0,68	0,78	0,88
480 / 50 / 2,5	21,6	F _v	34,9	24,2	17,8	13,6	10,8	8,7	7,2	6,1	5,2	4,45	3,9	3,4	3
		f	0,08	0,11	0,15	0,19	0,25	0,30	0,37	0,44	0,51	0,59	0,68	0,78	0,88
120 / 75 / 2,5	42,2	F _v	279,65	194,2	142,7	109,2	86,3	69,9	57,8	48,55	41,4	35,7	31,1	27,3	24,2
		f	0,05	0,07	0,10	0,13	0,17	0,20	0,25	0,29	0,35	0,40	0,46	0,52	0,59
180 / 75 / 2,5	33,4	F _v	186,4	129,5	95,1	72,8	57,5	46,6	38,5	32,4	27,6	23,8	20,7	18,2	16,1
		f	0,05	0,07	0,10	0,13	0,17	0,20	0,25	0,29	0,35	0,40	0,46	0,52	0,59
240 / 75 / 2,5	29,9	F _v	139,8	97,1	71,3	54,6	43,2	35	28,9	24,3	20,7	17,8	15,5	13,65	12,1
		f	0,05	0,07	0,10	0,13	0,17	0,20	0,25	0,29	0,35	0,40	0,46	0,52	0,59
300 / 75 / 2,5	27,3	F _v	111,9	77,7	57,1	43,7	34,5	28	23,1	19,4	16,55	14,3	12,4	10,9	9,7
		f	0,05	0,07	0,10	0,13	0,17	0,20	0,25	0,29	0,35	0,40	0,46	0,52	0,59
360 / 75 / 2,5	24,1	F _v	93,2	64,7	47,6	36,4	28,8	23,3	19,3	16,2	13,8	11,9	10,4	9,1	8,1
		f	0,05	0,07	0,10	0,13	0,17	0,20	0,25	0,29	0,35	0,40	0,46	0,52	0,59
420 / 75 / 2,5	25,9	F _v	79,9	55,5	40,8	31,2	24,7	20	16,5	13,9	11,8	10,2	8,9	7,8	6,9
		f	0,05	0,07	0,10	0,13	0,17	0,20	0,25	0,29	0,35	0,40	0,46	0,52	0,59
480 / 75 / 2,5	23,8	F _v	69,9	48,55	35,7	27,3	21,6	17,5	14,4	12,1	10,3	8,9	7,8	6,8	6,05
		f	0,05	0,07	0,10	0,13	0,17	0,20	0,25	0,29	0,35	0,40	0,46	0,52	0,59

* = Key to symbols

F_v = uniformly distributed load (UDL)
in kN/m²

1 kN = 1000 N = approx. 100 kg

f = deflection in cm at load F_v

span in mm													
800	900	1000	200	400	600	800	1000	200	400	600	800	1000	
7,4	6,7	6	5	4,2	3,55	3,1	2,7	2,35	2,1	1,85			
1,22	1,36	1,51	1,82	2,17	2,54	2,95	3,39	3,85	4,35	4,88			
4,9	4,4	4	3,3	2,8	2,4	2	1,8						
1,22	1,36	1,51	1,82	2,17	2,54	2,95	3,39						
3,7	3,3	3	2,5	2,1	1,8								
1,22	1,36	1,51	1,82	2,17	2,54								
3	2,7	2,4	2										
1,22	1,36	1,51	1,82										
2,5	2,2	2											
1,22	1,36	1,51											
2,1	1,9	1,7											
1,22	1,36	1,51											
1,85													
1,22													
10,8	9,7	8,7	7,2	6,1	5,2	4,45	3,9	3,4	3	2,7	2,4	2,2	
0,98	1,10	1,21	1,47	1,75	2,05	2,38	2,73	3,11	3,51	3,93	4,38	4,86	
7,2	6,4	5,8	4,8	4	3,4	3	2,6	2,3	2	1,8			
0,98	1,10	1,21	1,47	1,75	2,05	2,38	2,73	3,11	3,51	3,93			
5,4	4,8	4,4	3,6	3	2,6	2,2	1,9	1,7					
0,98	1,10	1,21	1,47	1,75	2,05	2,38	2,73	3,11					
4,3	3,9	3,5	2,9	2,4	2,1	1,8							
0,98	1,10	1,21	1,47	1,75	2,05	2,38							
3,6	3,2	2,9	2,4	2	1,7								
0,98	1,10	1,21	1,47	1,75	2,05								
3,1	2,8	2,5	2,1	1,7									
0,98	1,10	1,21	1,47	1,75									
2,7	2,4	2,2	1,8										
0,98	1,10	1,21	1,47										
21,6	19,4	17,5	14,4	12,1	10,3	8,9	7,8	6,8	6,05	5,4	4,9	4,4	
0,66	0,74	0,82	0,99	1,18	1,38	1,61	1,84	2,10	2,37	2,65	2,96	3,28	
14,4	12,9	11,65	9,6	8,1	6,9	5,9	5,2	4,55	4	3,6	3,2	2,9	
0,66	0,74	0,82	0,99	1,18	1,38	1,61	1,84	2,10	2,37	2,65	2,96	3,28	
10,8	9,7	8,7	7,2	6,1	5,2	4,5	3,4	3,4	3	2,7	2,4	2,2	
0,66	0,74	0,82	0,99	1,18	1,38	1,61	1,84	2,10	2,37	2,65	2,96	3,28	
8,6	7,75	7	5,8	4,85	4,1	3,6	3,1	2,7	2,4	2,2	1,9	1,75	
0,66	0,74	0,82	0,99	1,18	1,38	1,61	1,84	2,10	2,37	2,65	2,96	3,28	
7,2	6,5	5,8	4,8	4,05	3,45	3	2,6	2,3	2	1,8			
0,66	0,74	0,82	0,99	1,18	1,38	1,61	1,84	2,10	2,37	2,65			
6,2	5,5	5	4,1	3,5	2,95	2,55	2,2	1,95	1,7				
0,66	0,74	0,82	0,99	1,18	1,38	1,61	1,84	2,10	2,37				
5,4	4,8	4,4	3,6	3	2,6	2,2	1,9						
0,66	0,74	0,82	0,99	1,18	1,38	1,61	1,84						

Data

Material stress (permissible tension):
16 kN/cm² (Material S235JR $\hat{=}$ St 37-2)

Safety factor to yield point: 1,5

Safety factor to breaking limit: 2,05

The **perforated metal plank support** should provide a bearing distance at each end of at least 25 mm. Deviations may be permitted, providing suitable measures are taken to prevent excessive movement away from the supports (see instruction sheet BDI 588).

Pedestrian traffic

Yellow: Perforated metal planks manufactured in accordance with the requirements of instruction sheet BGI 588 of the Berufsgenossenschaft professional association and to quality instructions RAL-GZ 639, are considered suitable for pedestrian traffic when they meet the following design criteria: The maximum permissible deflection 'f', does not exceed 1/200th of the span 'L' or 4 mm whichever is the lesser, under a concentrated load of 1,5 kN applied in the most unfavourable position, over a concentrated load area of 200 x 200 mm.

Green: The maximum permissible deflection 'f', does not exceed 1/200th of the span 'L', under a concentrated load of 1,5 kN applied in the most unfavourable position, over a concentrated load area of 200 x 200 mm.

Blue: The maximum permissible deflection 'f', does not exceed 1/200th of the span 'L', under a uniformly distributed load of 5 kN/m².

Multiplication factor for other materials

Material		load	deflection
Stainless steel 1	4301	0,82	0,84
Stainless steel 1	4571	0,88	0,90
Aluminum AlMg3	G 22	0,54	1,61

Larger spans are possible.

BP BR BZ Loadtable for concentrated loads

The table indicates possible concentrated load „F_p“ in kN and the deflection „f“ in cm. Material S 235 JR (≙ St 37-2). Contact area 200 x 200 mm. Max. concentrated load in direction „B“ is to be considered.

	Type	approx. gal. weight kg/m ²	load/ deflection	span in mm															
				250	300	400	500	600	700	800	900	1000	1100	1200	1300	1400	1500	1600	
BP	200 / 30 / 2	21,4	F _p	4	4	3,15	2,35	1,9	1,6	1,35	1,2	1,05	0,95	0,85	0,75				
			f	0,03	0,04	0,08	0,12	0,17	0,22	0,29	0,36	0,44	0,53	0,63	0,74				
	200 / 50 / 2	24,8	F _p	4	4	4	4	4	3,45	2,95	2,6	2,3	2,1	1,9	1,7	1,6	1,5	1,35	
			f	0,03	0,03	0,05	0,07	0,10	0,14	0,18	0,22	0,27	0,32	0,38	0,45	0,52	0,59	0,67	
	200 / 75 / 2	29,1	F _p	4	4	4	4	4	4	4	4	4	4	3,95	3,6	3,3	3,05	2,8	2,65
			f	0,03	0,03	0,03	0,05	0,07	0,09	0,12	0,15	0,18	0,22	0,26	0,30	0,35	0,40	0,45	
200 / 100 / 2	33,2	F _p	4	4	4	4	4	4	4	4	4	4	4	4	4	4	4	4	
		f	0,03	0,03	0,03	0,04	0,05	0,07	0,09	0,11	0,14	0,16	0,19	0,23	0,26	0,30	0,34		
BP	200 / 30 / 2,5	27,1	F _p	5,3	5,3	5,3	2,8	2,25	1,85	1,6	1,4	1,25	1,1	1	0,95	0,85	0,8	0,75	
			f	0,03	0,04	0,08	0,12	0,17	0,22	0,29	0,36	0,44	0,53	0,63	0,74	0,85	0,97	1,10	
	200 / 50 / 2,5	31,4	F _p	5,3	5,3	5,3	5,3	5	4,15	3,55	3,1	2,75	2,5	2,25	2,05	1,9	1,8	1,65	
			f	0,02	0,03	0,05	0,07	0,10	0,14	0,18	0,22	0,27	0,32	0,38	0,45	0,52	0,59	0,67	
	200 / 75 / 2,5	36,6	F _p	5,3	5,3	5,3	5,3	5,3	5,3	5,3	5,3	5,3	4,8	4,35	4	3,7	3,45	3,2	
			f	0,01	0,02	0,03	0,05	0,07	0,09	0,12	0,15	0,18	0,22	0,26	0,30	0,35	0,40	0,45	
200 / 100 / 2,5	41,8	F _p	5,3	5,3	5,3	5,3	5,3	5,3	5,3	5,3	5,3	5,3	5,3	5,3	5,3	5,3	5,2		
		f	0,01	0,02	0,03	0,04	0,05	0,07	0,09	0,11	0,14	0,16	0,19	0,23	0,26	0,30	0,34		
BR	200 / 30 / 2	21,4	F _p	6,3	4,7	3,15	2,35	1,9	1,6	1,35	1,2	1,05	0,95	0,85	0,75				
			f	0,03	0,04	0,08	0,12	0,17	0,22	0,29	0,36	0,44	0,53	0,63	0,74				
	200 / 50 / 2	24,8	F _p	8,1	8,1	6,85	5,2	4,15	3,45	2,95	2,6	2,3	2,1	1,9	1,7	1,6	1,5	1,35	
			f	0,03	0,03	0,05	0,07	0,10	0,14	0,18	0,22	0,27	0,32	0,38	0,45	0,52	0,59	0,67	
	200 / 75 / 2	29,1	F _p	8,1	8,1	8,1	8,1	7,9	6,6	5,65	4,95	4,4	3,95	3,6	3,3	3,05	2,8	2,65	
			f	0,03	0,03	0,03	0,05	0,07	0,09	0,12	0,15	0,18	0,22	0,26	0,30	0,35	0,40	0,45	
200 / 100 / 2	33,2	F _p	8,1	8,1	8,1	8,1	8,1	8,1	8,1	7,95	7,1	6,35	5,8	5,3	4,9	4,55	4,25		
		f	0,03	0,03	0,03	0,04	0,05	0,07	0,09	0,11	0,14	0,16	0,19	0,23	0,26	0,30	0,34		
BR	200 / 30 / 2,5	27,1	F _p	7,45	5,6	3,75	2,8	2,25	1,85	1,6	1,4	1,25	1,1	1	0,95	0,85	0,8	0,75	
			f	0,03	0,04	0,08	0,12	0,17	0,22	0,29	0,36	0,44	0,53	0,63	0,74	0,85	0,97	1,10	
	200 / 50 / 2,5	31,4	F _p	10,1	10,1	8,3	6,2	4,95	4,15	3,55	3,1	2,75	2,5	2,25	2,05	1,9	1,8	1,65	
			f	0,02	0,03	0,05	0,07	0,10	0,14	0,18	0,22	0,27	0,32	0,38	0,45	0,52	0,59	0,67	
	200 / 75 / 2,5	36,6	F _p	10,1	10,1	10,1	10,1	9,6	8	6,85	6	5,35	4,8	4,35	4	3,7	3,45	3,2	
			f	0,01	0,02	0,04	0,05	0,07	0,09	0,12	0,15	0,18	0,22	0,26	0,30	0,35	0,40	0,45	
200 / 100 / 2,5	41,8	F _p	10,1	10,1	10,1	10,1	10,1	10,1	10,1	9,75	8,65	7,8	7,1	6,5	6	5,55	5,2		
		f	0,01	0,02	0,03	0,04	0,05	0,07	0,09	0,11	0,14	0,16	0,19	0,23	0,26	0,30	0,34		
BZ	240 / 40 / 2	19,2	F _p	4,2	4,2	4	3	2,4	2	1,7	1,5	1,35	1,2	1,1	1	0,9	0,9	0,8	
			f	0,03	0,04	0,05	0,09	0,12	0,17	0,21	0,27	0,33	0,39	0,47	0,55	0,63	0,72	0,82	
	240 / 50 / 2	20,6	F _p	4,2	4,2	4,2	4,2	3,5	2,9	2,5	2,2	1,9	1,75	1,6	1,45	1,3	1,25	1,2	
			f	0,02	0,03	0,04	0,07	0,10	0,13	0,17	0,22	0,26	0,32	0,38	0,44	0,51	0,58	0,66	
	240 / 75 / 2	24,1	F _p	4,2	4,2	4,2	4,2	4,2	4,2	4,2	4,2	3,8	3,5	3,1	2,9	2,7	2,5	2,3	
			f	0,01	0,02	0,03	0,05	0,07	0,09	0,12	0,15	0,18	0,21	0,25	0,30	0,34	0,39	0,44	
BZ	240 / 40 / 2,5	23,8	F _p	4,7	4,7	4,7	3,6	2,9	2,4	2,1	1,8	1,6	1,4	1,3	1,2	1,1	1	1	
			f	0,03	0,04	0,05	0,09	0,12	0,17	0,21	0,27	0,33	0,39	0,47	0,55	0,63	0,72	0,82	
	240 / 50 / 2,5	25,6	F _p	4,7	4,7	4,7	4,7	4,2	3,5	3	2,6	2,3	2,1	1,9	1,7	1,6	1,5	1,4	
			f	0,02	0,03	0,04	0,07	0,10	0,13	0,17	0,22	0,26	0,32	0,38	0,44	0,51	0,58	0,66	
	240 / 75 / 2,5	29,9	F _p	4,7	4,7	4,7	4,7	4,7	4,7	4,7	4,7	4,7	4,7	4,2	3,8	3,5	3,2	3	2,8
			f	0,01	0,02	0,03	0,05	0,07	0,09	0,12	0,15	0,18	0,21	0,25	0,30	0,34	0,39	0,44	

1 kN = 1000 N = approx. 100 kg

Multiplication factor for load table

B	load	deflection
120	1,65	1,00
150	1,35	1,00
180	1,10	1,00
200	1,00	1,00
240	1,00	1,00
250	1,00	1,00
300	1,00	1,00
360	1,00	1,00
420	1,00	1,00
480	1,00	1,00

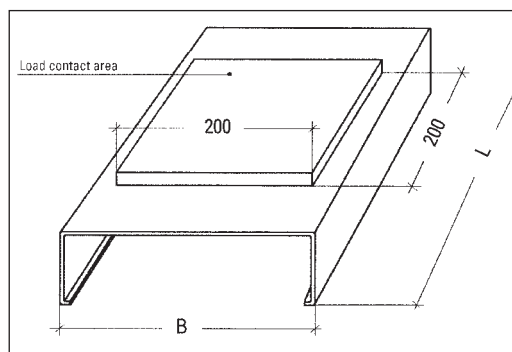

span in mm													
1,3	1,25	1,15	1,1	1	0,9	0,85	0,75						
0,75	0,84	0,94	1,03	1,25	1,48	1,73	2,00						
2,45	2,3	2,2	2,1	1,9	1,7	1,6	1,45	1,35	1,25	1,2	1,15	1,05	1
0,51	0,57	0,63	0,69	0,84	0,99	1,16	1,34	1,54	1,75	1,97	2,21	2,46	2,72
4	3,75	3,55	3,35	3,05	2,75	2,55	2,35	2,2	2,05	1,95	1,8	1,7	1,65
0,38	0,43	0,47	0,52	0,63	0,75	0,88	1,01	1,16	1,32	1,49	1,66	1,85	2,05
1,55	1,45	1,4	1,3	1,2	1,1	1	0,9	0,85	0,8	0,75			
0,75	0,84	0,94	1,03	1,25	1,48	1,73	2,00	2,29	2,61	2,94			
3	2,8	2,65	2,55	2,3	2,1	1,9	1,8	1,65	1,55	1,45	1,35	1,3	1,25
0,51	0,57	0,63	0,69	0,84	0,99	1,16	1,34	1,54	1,75	1,97	2,21	2,46	2,72
4,85	4,6	4,3	4,1	3,7	3,4	3,1	2,9	2,7	2,5	2,35	2,2	2,1	2
0,38	0,43	0,47	0,52	0,63	0,75	0,88	1,01	1,16	1,32	1,49	1,66	1,85	2,05
1,3	1,25	1,15	1,1	1	0,9	0,85	0,75						
0,75	0,84	0,94	1,03	1,25	1,48	1,73	2,00						
2,45	2,3	2,2	2,1	1,9	1,7	1,6	1,45	1,35	1,25	1,2	1,15	1,05	1
0,51	0,57	0,63	0,69	0,84	0,99	1,16	1,34	1,54	1,75	1,97	2,21	2,46	2,72
4	3,75	3,55	3,35	3,05	2,75	2,55	2,35	2,2	2,05	1,95	1,8	1,7	1,65
0,38	0,43	0,47	0,52	0,63	0,75	0,88	1,01	1,16	1,32	1,49	1,66	1,85	2,05
1,55	1,45	1,4	1,3	1,2	1,1	1	0,9	0,85	0,8	0,75			
0,75	0,84	0,94	1,03	1,25	1,48	1,73	2,00	2,29	2,61	2,94			
3	2,8	2,65	2,55	2,3	2,1	1,9	1,8	1,65	1,55	1,45	1,35	1,3	1,25
0,51	0,57	0,63	0,69	0,84	0,99	1,16	1,34	1,54	1,75	1,97	2,21	2,46	2,72
4,85	4,6	4,3	4,1	3,7	3,4	3,1	2,9	2,7	2,5	2,35	2,2	2,1	2
0,38	0,43	0,47	0,52	0,63	0,75	0,88	1,01	1,16	1,32	1,49	1,66	1,85	2,05
0,8	0,7	0,7	0,6										
0,92	1,03	1,14	1,26										
1,1	1	1	0,9	0,8	0,7	0,65							
0,74	0,83	0,92	1,02	1,23	1,45	1,70	1,97						
2,2	2	1,9	1,8	1,65	1,5	1,4	1,3	1,2	1,1	1,05	1	0,9	0,9
0,50	0,56	0,62	0,69	0,83	0,98	1,15	1,33	1,52	1,73	1,95	2,18	2,43	2,69
0,9	0,85	0,8	0,8	0,7	0,6								
0,92	1,03	1,14	1,26	1,52	1,80								
1,3	1,2	1,2	1,1	1	0,9	0,8	0,8	0,7	0,7	0,6			
0,74	0,83	0,92	1,02	1,23	1,45	1,70	1,97	2,26	2,56	2,89			
2,6	2,5	2,3	2,2	2	1,8	1,7	1,55	1,45	1,35	1,3	1,2	1,1	1,1
0,50	0,56	0,62	0,69	0,83	0,98	1,15	1,33	1,52	1,73	1,95	2,18	2,43	2,69

Larger spans are possible.

Max. possible concentrated load over a contact area of 200 x 200 mm in kN in direction „B“						
B	Type BP		Type BR		Type BZ	
	2 mm thick	2,5 mm thick	2 mm thick	2,5 mm thick	2 mm thick	2,5 mm thick
120					29,80	33,25
150	8,05	10,65	16,30	20,25		
180					7,40	8,25
200	4,00	5,30	8,10	10,10		
240					4,20	4,70
250	2,65	3,55	5,40	6,75		
300	2,00	2,65			2,85	3,25
360					2,25	2,55
420					1,80	2,05
480					1,55	1,70

* = Key to symbols

F_p = value of concentrated load in kN when uniformly distributed over a concentrated load area of 200 x 200 mm

f = deflection in cm at load F_p

Material stress (permissible load):

16 kN/cm² (Material S235JR $\hat{=}$ St 37-2)

Safety factor to yield point: 1,5

Safety factor to breaking limit: 2,05

The **perforated metal plank support** should provide a bearing distance at each end of at least 25 mm. Deviations may be permitted, providing suitable measures are taken to prevent excessive movement away from the supports (see instruction sheet BDI 588).

Pedestrian traffic

Yellow: Perforated metal planks manufactured in accordance with the requirements of instruction sheet BGI 588 of the Berufsgenossenschaft professional association and to quality instructions RAL-GZ 639, are considered suitable for pedestrian traffic when they meet the following design criteria:

The maximum permissible deflection 'f', does not exceed 1/200th of the span 'L' or 4 mm whichever is the lesser, under a concentrated load of 1,5 kN applied in the most unfavourable position, over a concentrated load area of 200 x 200 mm.

Multiplication factor for other materials

Material	load	deflection
Stainless steel 1.4301	0,81	0,95
Stainless steel 1.4571	0,87	0,95
Aluminum AlMg 3 G 22	0,54	1,60

Concentrated loads BN-O and BN-G

Limited concentrated loads for BN-O and BN-G see pages 50/51. The end of the yellow region indicates a concentrated load of 1,5 kN in a contact area of 200 x 200 mm at a max. deflection „f“ of 4 mm. The end of the green region indicates a concentrated load of 1,5 kN in a contact area of 200 x 200 mm, whereby the deflection „f“ is < L/200.

B Treads

Standard and tailor-made perforated metal plank treads are fabricated using the same patterns as used for the landings in order to ensure the complete staircase has a homogeneous appearance (Requirements for steel stairs - see page 19).

The optimal level of safety may be achieved by supplying treads complete with a serrated nosing.

Treads can also be produced in stainless steel quality 1.4301 and 1.4571, as well as in aluminum AIMg 3 G 22.

Standard treads

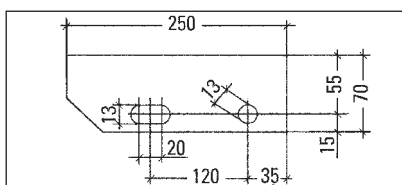

Dimensions	Type
600 x 250 mm	BP
700 x 250 mm	BP
800 x 250 mm	BP
900 x 250 mm	BP
1000 x 250 mm	BP

Upon request, we can supply fixings for treads consisting of:

- hexagon screw M 12 x 35, DIN EN 24018
- hexagon nut M 12, DIN EN 24034
- washer A 14, DIN 7989.

Tailor-made treads

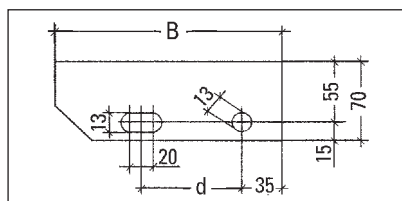
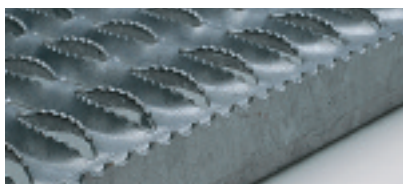

Tailor-made treads are produced with serrated nosing upon request. Depending on the perforated metal type required, preferred widths (dimension B) are 150 mm, 200 mm, 240 mm 250 mm and 300 mm. The required position of fixing holes (dimension d), should be indicated separately.

Perf. Metal Plank type	Dimension	Size 'd'	
BN-O / BN-G 240 / 50 / 2	600 x 240 mm	120 mm	
BN-O / BN-G 240 / 75 / 2	800 x 240 mm	120 mm	
BN-O / BN-G 240 / 75 / 2	1000 x 240 mm	120 mm	
BN-O / BN-G 240 / 75 / 2	1200 x 240 mm	120 mm	
BN-O / BN-G 270 / 50 / 2,5	600 x 270 mm	150 mm	
BN-O / BN-G 270 / 50 / 2,5	800 x 270 mm	150 mm	
BN-O / BN-G 270 / 75 / 2,5	1000 x 270 mm	150 mm	
BN-O / BN-G 270 / 75 / 2,5	1200 x 270 mm	150 mm	
BN-O / BN-G 300 / 50 / 2,5	600 x 300 mm	180 mm	
BN-O / BN-G 300 / 50 / 2,5	800 x 300 mm	180 mm	
BN-O / BN-G 300 / 75 / 2,5	1000 x 300 mm	180 mm	
BN-O / BN-G 300 / 75 / 2,5	1200 x 300 mm	180 mm	
BP	300 / 50 / 2	600 x 300 mm	180 mm
BP	300 / 50 / 2	800 x 300 mm	180 mm
BP	300 / 75 / 2	1000 x 300 mm	180 mm
BP	300 / 75 / 2	1200 x 300 mm	180 mm
BZ	240 / 50 / 2	600 x 240 mm	120 mm
BZ	240 / 75 / 2	800 x 240 mm	120 mm
BZ	240 / 75 / 2	1000 x 240 mm	120 mm
BZ	240 / 75 / 2	1200 x 240 mm	120 mm
BZ	270 / 50 / 2,5	600 x 270 mm	150 mm
BZ	270 / 50 / 2,5	800 x 270 mm	150 mm
BZ	270 / 75 / 2,5	1000 x 270 mm	150 mm
BZ	270 / 75 / 2,5	1200 x 270 mm	150 mm
BZ	300 / 50 / 2,5	600 x 300 mm	180 mm
BZ	300 / 50 / 2,5	800 x 300 mm	180 mm
BZ	300 / 75 / 2,5	1000 x 300 mm	180 mm
BZ	300 / 75 / 2,5	1200 x 300 mm	180 mm

Other dimensions on request

LSP Ladder Rungs

Permanently fixed vertical ladders made out of steel, are often used in iron and steel making plants, rolling mills, mining, the chemical industry, power plants and many other fields where good tread safety on rungs is specifically required.

In order to ensure this level of safety on tread surfaces, special slip resistant ladder rungs can be supplied to suit most applications.

These rungs can be fixed over the round rungs of existing ladders and welded laterally to either a cross member or steel angle. For fitting to ladders with 25 mm dia. rungs, type LSP 35 special rungs are recommended.

For new ladders, we would recommend the supply of special rung types LSP 50G and LSP 50R.

The surface structure of all our special ladder rungs is serrated, although not

susceptible to dirt accumulation and offers a very good level of safety, even during extreme working conditions. Thus, the essential safety requirements are fulfilled.

Ladder rungs are supplied in a standard finish (self coloured), but an additional surface treatment can be provided upon request.

Ladder rungs LSP 25

Description: 800/25/39/2 mm
 Materials: Steel
 Stainless steel 1.4301
 Stainless steel 1.4571
 Aluminum AlMg 3 G 22
 Length: 800 mm
 Surface: self-coloured

LSP 25

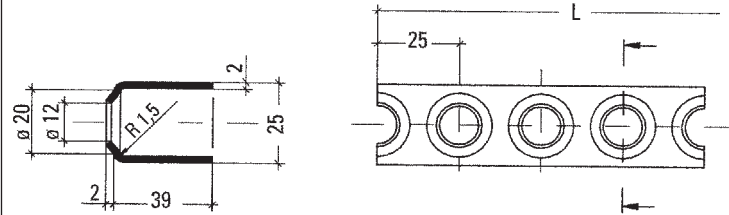

Ladder rungs LSP 35

Description: 2000/35/34/2 mm
 Materials: Steel
 Stainless steel 1.4301
 Stainless steel 1.4571
 Aluminum AlMg 3 G 22
 Length: 2000 mm
 Surface: self-coloured

LSP 35

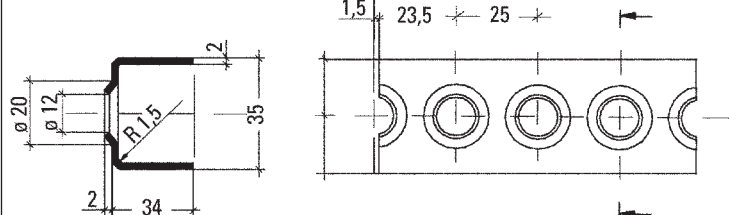

Ladder rungs LSP 50

Description: 2000/50/39/2 mm
 Materials: Steel
 Stainless steel 1.4301
 Stainless steel 1.4571
 Aluminum AlMg 3 G 22
 Length: 2000 mm
 Surface: self-coloured
 LSP 50 G: 497/50/39/2 mm with straight ends
 LSP 50 R: 485/50/39/2 mm with round ends suitable for tube \varnothing 48,3 mm

LSP 50 R

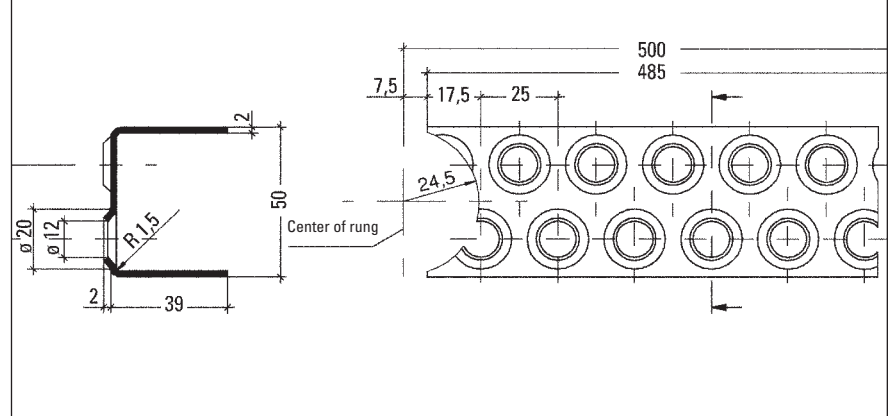

Regarding the use of ladder rungs type LSP 50 we refer to the standard EN ISO 14122, part 4: Permanent stepladders.



B Fixings for Perforated Metal Planks

We recommend our specially developed Lichtgitter fixings for all types of perforated metal planks and underside support.

Perforated metal planks should be prevented from lifting up and slipping off. Every element having a width greater than 300 mm should be attached from at least four points to the underside support, otherwise two fixings are sufficient.

The under parts of fixings are adjusted to suit the appropriate types of perforated metal plank and the different types of underside supports they may have. All screws and nuts are either supplied in stainless steel, or like all other fixing parts, supplied centrifugally galvanised

to DIN 267, page 10.

By screwing together perforated metal planks (if possible, at every 500 mm centres, see fixing no. 27,28 & 29), stumbling edges are avoided and a greater level of load distribution is achieved. Fixings are supplied loose with perforated metal planks and details relating to their attachment can be found in „Arbeitsstätten-Verordnung“, §12: 'Protection against falling objects'.

All fixings require service and should be regularly inspected regarding their efficiency. The inspection intervals depend on operating conditions. The user may have to **hand-screw** fixings.

Therefore, all fixing materials are excluded from legal warranty.

Notice

The clamp upper part with **BZ-gratings** is an „olive“. For all other types no special upper part is necessary.

To avoid deflection at the intersection of perforated metal planks, the use of thrust connections no. 24 for types **BN-G** and **BN-O** are recommended.

The fixing number plus indication of the grating height and type of perforated metal plank, form the description and order number of the fixing. For example

fixing no.	B 21
grating height	50
and type BP	„P“
form order no.	B 2150 P.

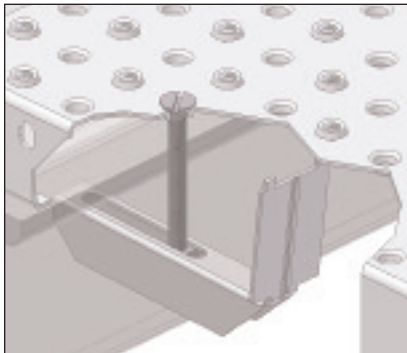

No. 21 Standard fixing

clamp connection, consisting of:

- under part
- flat headed screw M 8 x ... ISO 2009 (DIN 963)
- square nut M 8 DIN 557
- and for BZ-gratings additionally with „olive“

This fixing is suitable for the types BR, BP, BP-Ü, BZ and BN-O.

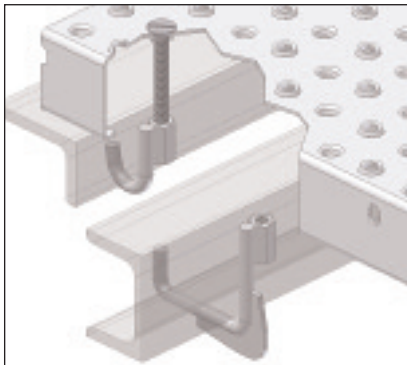

No. 22 Hook screw-fixing

for perforated metal planks on vertical support profiles without bottom flange, consisting of:

- under part
- flat head screw M 8 ...ISO 2009 (DIN 963)
- and for BZ-gratings additionally with „olive“

profile of underside support must be indicated upon order.

No. 23 as per no. 22, but vertical support profiles with bottom flange.

This fixing is suitable for the types BR, BP, BP-Ü, BZ and BN-O.

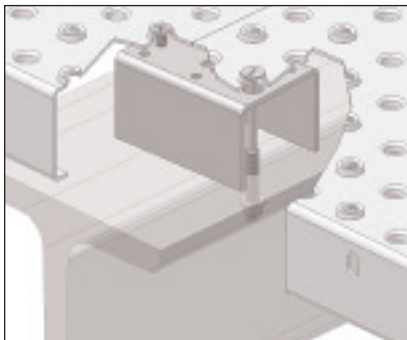

No. 24 Thrust connection

avoids stumbling edges at intersection and enables an attachment to underside support. Consisting of:

- U-Profile
- flat head screw M 8 x ...ISO 2009 (DIN 963)
- alternatively: tapping flat-headed screw acc. to ISO 7050 (DIN 7982)
- washer 9 DIN 126
- nut M 8 ISO 7042 (DIN 980), self-locking.

This fixing is suitable for the types BN-O and BN-G. Necessary boring in the perforated metal plank BN-G has to be done at site.



No. 32 Olive

Fixing upper part for BZ-perforated metal planks.

Material grey cast iron without surface treatment or made of synthetic PA 6.6.

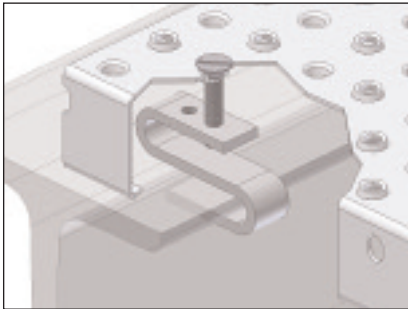

No. 25 S-Clamp

is a clamp connection consisting of:

- S-hook (suitable for underside support with a flange thickness of max. 9 mm)
- flat head screw M 8 x... ISO 2009 (DIN 963)
- and for BZ-gratings additionally with „olive“.

This fixing is suitable for the types BR, BP, BP-Ü and BZ.

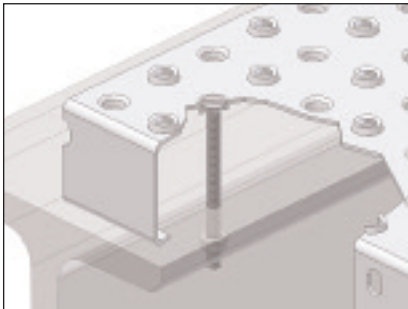

No. 26 Direct screwing

forms a safe connection with underside support, consisting of:

- flat head screw M 8 x ... ISO 2009 (DIN 963)
 - washer 9 DIN 126
 - nut M 8 ISO 7042 (DIN 980), self-locking.
- type BZ with „olive“.

This fixing is suitable for the types BR, BP, BP-Ü, BZ and BN-O.

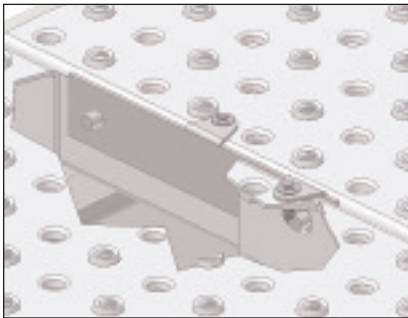

No. 27 Element thrust connection

avoids stumbling edges and enhances load distribution on larger spans at unfixed points.

Consisting of:

- connection part
- self-tapping screw D M 5 x 20 DIN 7516.

This fixing is suitable for the types BR, BP, BP-Ü, BZ, BN-O and BN-G.



No. 29 Screw connection

consisting of:

- screw M 8 x 20 ISO 4017 (DIN 933)
- washer 9 DIN 126 and nut M 8 ISO 7042 (DIN 980), self-locking.

This fixing is suitable for the types BR, BP, BP-Ü, BZ, BN-O and BN-G



No. 30 Fixing angle

avoids lifting off perforated metal planks.

Consisting of:

- piece of angle 30/30/3 ... 50 mm length
- 2 pieces self-tapping screws D M 5 x 20 DIN 7516.

This fixing is suitable for the types BR, BP, BP-Ü, BZ, BN-O and BN-G.



No. 31 Thrust flap

Suitable for connecting grating elements together at thrust and areas of restricted load transmission.

The position of screws, washers and nuts are adjusted to line up with existing holes in connections.

This fixing is suitable for the types BR, BP, BP-Ü, BZ, BN-O and BN-G.

BZ BP-Ü Walkway Elements

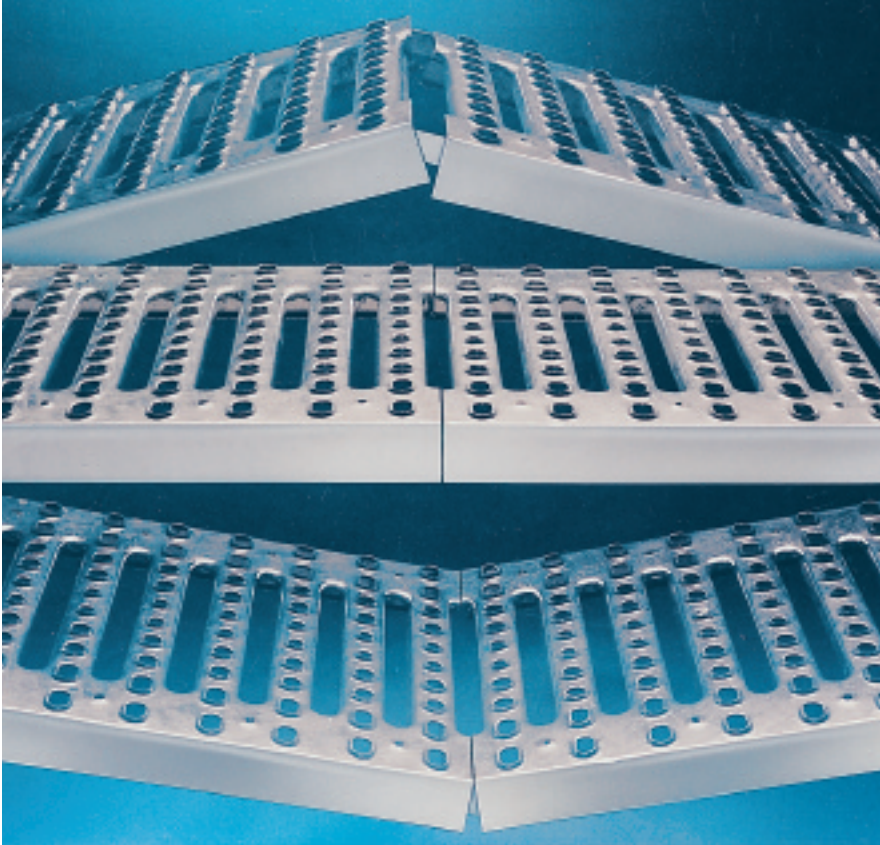

Adaptive elements at floor unevennesses



„travel way“ underground

Walkway elements with hook fastening (Patent no. DE 39 11 526 C2) are used as a „travel way“ for underground applications (mining, etc.). The types used are BZ (see page 43) as well as BP-Ü (see page 44).



Hook fastening

The major advantages of this patent protected hook fastening are:

- easy cleaning
- no stumbling edges at connecting parts, either from inclination or uneven levels
- reduction in labour requirement during installation of the single elements, „travel ways“ no longer need to be screwed, but can be connected to each other by using hook fastenings
- no separate unfastening of elements; minor radii at uneven floors may be compensated for, by using hook fastenings
- simple replacement of walkway elements in case of repair
- no corrosion at welding points because of galvanising according to DIN EN ISO 1461
- straight walkways can be complemented with curved and T-pieces to provide a complete system
- serration inspected by BIA
- immediate delivery ex stock

The following dimensions and types can be delivered ex stock.

Walkway elements for mining
 3000 / 400 / 50 / 2 type BZ
 3000 / 350 / 50 / 2 type BP-Ü
 3000 / 400 / 50 / 2 type BP-Ü.

Walkway elements with laterally welded anchor flaps can be fabricated, upon request.

B**Perforated Metal Planks designed for Sprinkler Systems**

In order to meet specific fire protection regulations in multi-floor towers and/or buildings with closed ceilings, sprinkler systems should be supplied.

However, by installing perforated metal planks as ceilings in areas above landings, walkways and platforms, it becomes unnecessary to have to provide additional sprinkler systems on every floor.

In these cases perforated metal planks of the following types can be used.

BZ**BP****BR**

These products have been inspected by the Insurance Association „Sachversicherer e.V. (VdS)“ with regard to the requirements for permitted sprinkler systems in buildings and towers. It is a particular requirement that the distance between the sprinkler plate and the tops of perforated metal planks, be at least 500 mm.

For safety reasons, the covering of perforated metal planks with materials or other items is not allowed. The test results show that Lichtgitter perforated metal planks perform exceptionally well in fire extinguishing situations.

A shorter response time and access to each individual floor, is provided for sprinkler systems having favourable water distribution in areas having suitable perforated metal planks. Homogeneous water distribution supports the fire extinguishing process within the affected building.

As results of the fire tests show, the installation of ceilings made out of perforated metal planks, does not negatively affect fire fighting activities. Temperature distribution and warning signs remain virtually unchanged when perforated metal planks are used.

Test have shown that the installation of type BR 250/50/2 perforated metal plank provides a shorter response time than tests carried out where closed ceilings have been installed. The accreditation given by the Insurance Association, 'Sachversicherer e.V.', guarantees full insurance cover in case of damage, without having to go to the additional expense of complying with any construction precautions levied, or other insurance preconditions.

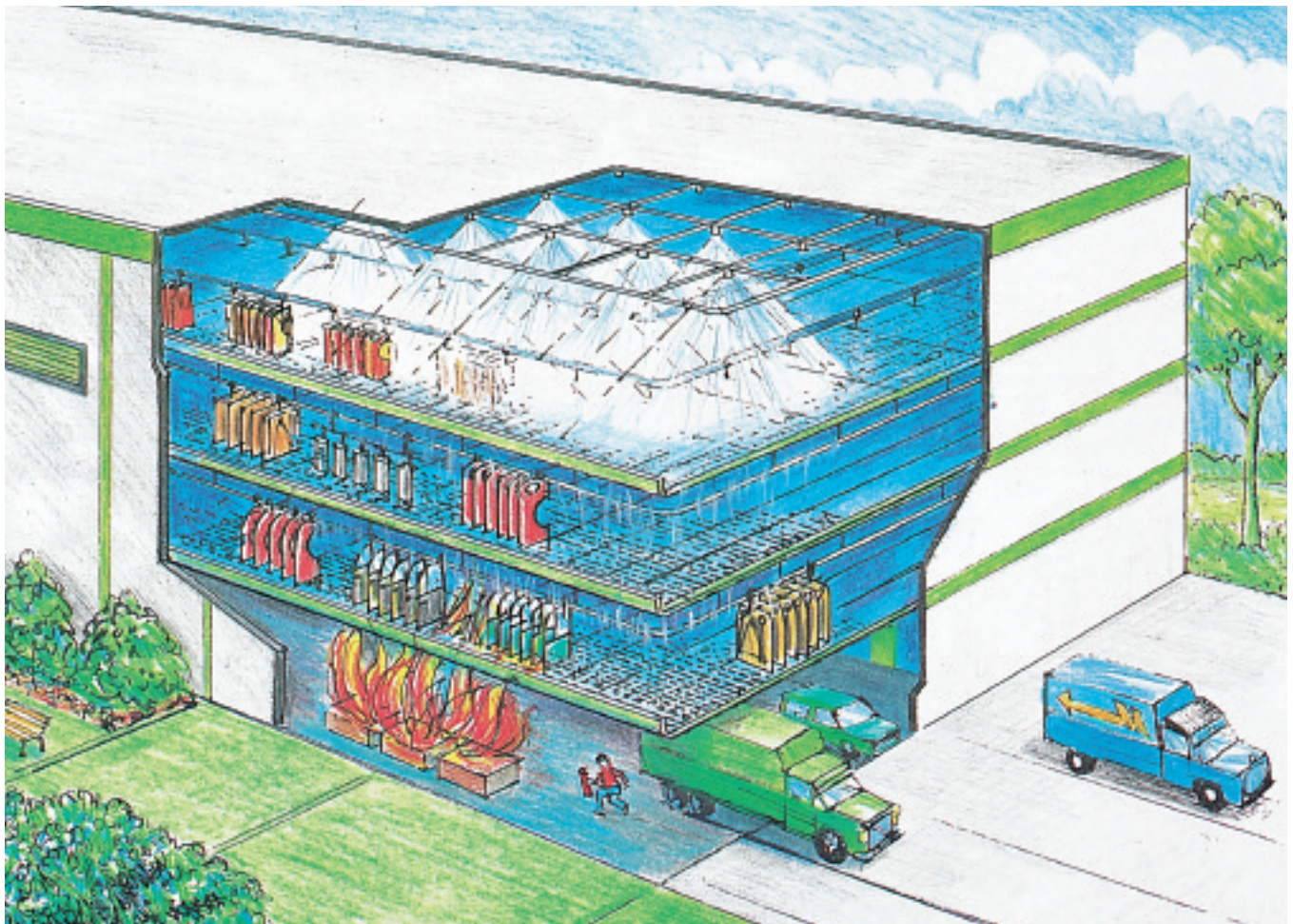

Perforated metal planks, specifically designed for sprinkler systems in buildings with several floors

BP BR Perforated Metal Planks as Protection Panels

Protection panels made from perforated metal planks can be used with particularly good results below conveyor belt systems for the automotive industry. The design and technical finish of the protection panels are produced to serve as an alternative to the well-known wire gratings.

One of the many advantages is that greater loads can be carried. For example, the elements are delivered pre-treated, in dimensions of 3000 x 1000 mm. By providing a notch in the support area, the elements will not slip in the direction of span, even when not fixed down.

Loads greater than 1,5 kN produced by conveyor systems or other aggregates are imposed directly upon the steel supporting structure by using a specially developed adapter (see sketch below) with elongated holes and distance tubes.

It is possible to change aggregates without making new cutouts into the covering. All work can be done from above, without the requirement for scaffolding, shortening the installation time significantly.

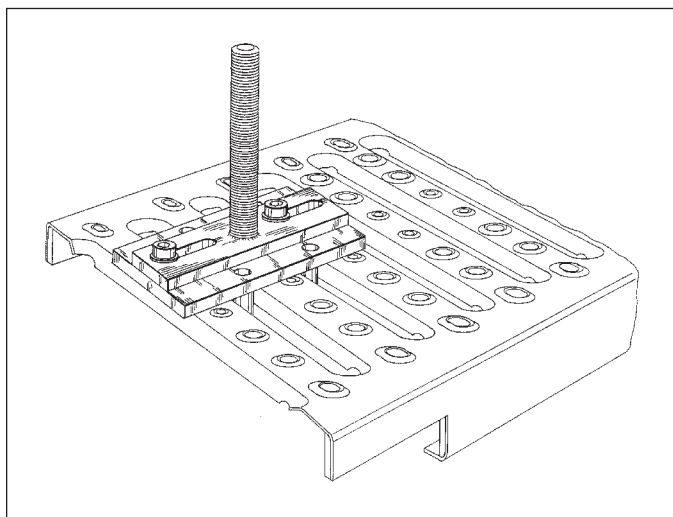
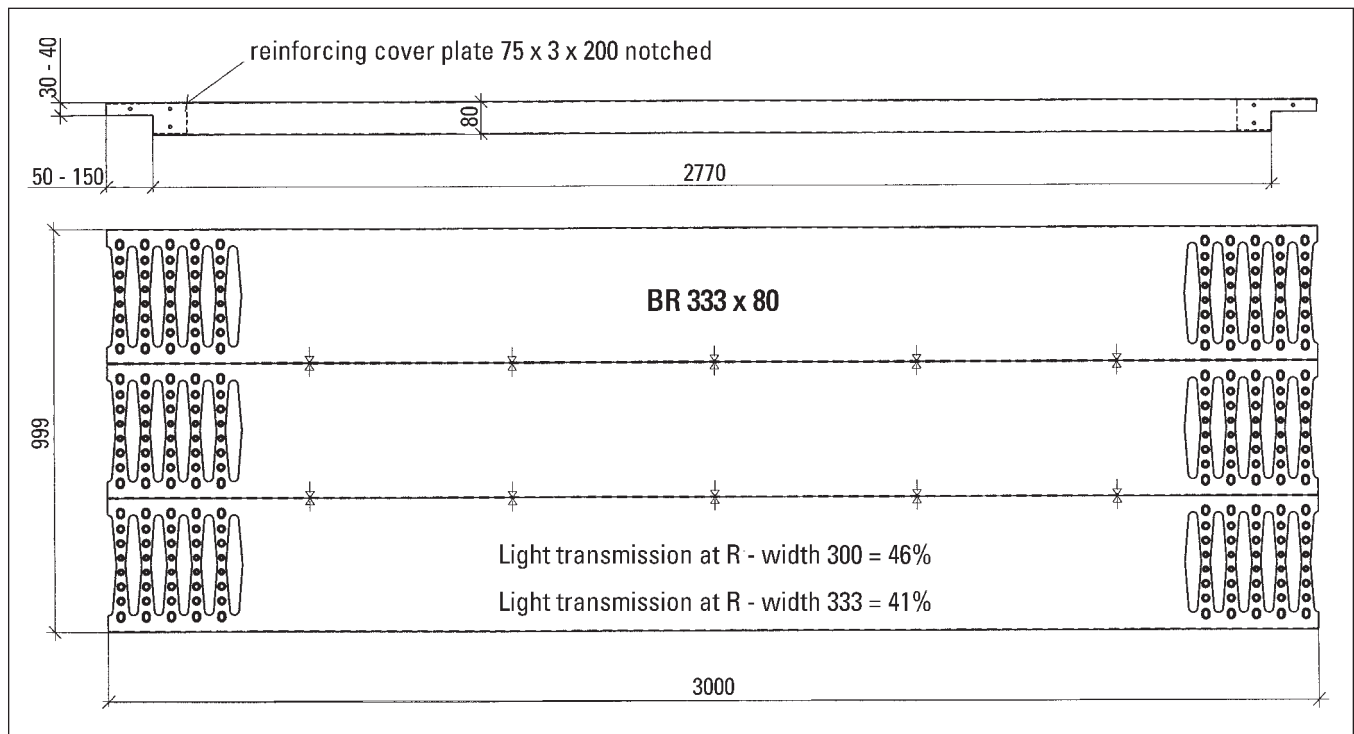

This type is protected by patent; patent n° 198 18 133

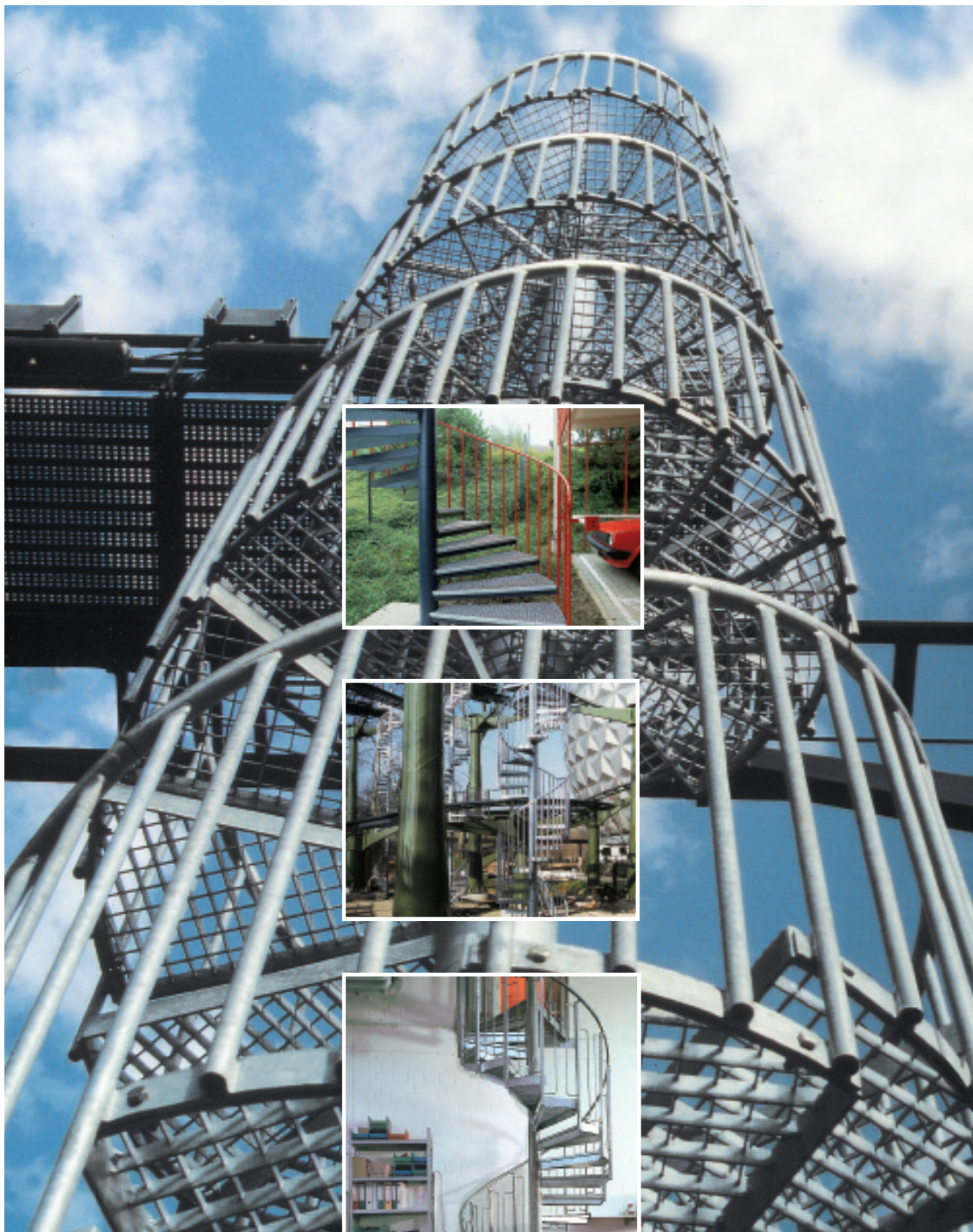

T Spiral Staircase „LG Standard“

Lichtgitter have developed two systems of spiral staircase to suit specific constructive and static requirements. Type „LG Standard“ (diameter of staircase in three standard sizes) and type „LG Special“ (diameter of staircase is variable up to 2700 mm).

Spiral staircases type „LG Standard“

in galvanised finish are produced in a building-block system with a diameter of 1600, 1800 and 2000 mm (max. diameter of staircases).

Spiral staircases „LG Standard“ are particularly easy to self-assemble.

Stairs and handrailing elements of different stair angles (stairs/spiral) can be used with this type of construction.

We can offer these staircases at reasonable prices and with short delivery terms due to the availability of standard sizes.

Calculations are carried out to determine the design requirements for staircases, by considering a uniformly distributed load of either 3,5 kN/sq.m., or a concentrated load of 1,5 kN applied over an area of 100 x 100 mm from the leading edge of the nosing, at a distance of 100 mm from the outside line of the stair. Spiral staircase systems provided by Lichtgitter have been inspected by the appropriate department of the German Ministry (see test report '11 B 6-543-206' dated 09.11.1995).

Tread widths are supplied in accordance with the German Standard DIN 18065.



T Spiral Staircase „LG Standard“

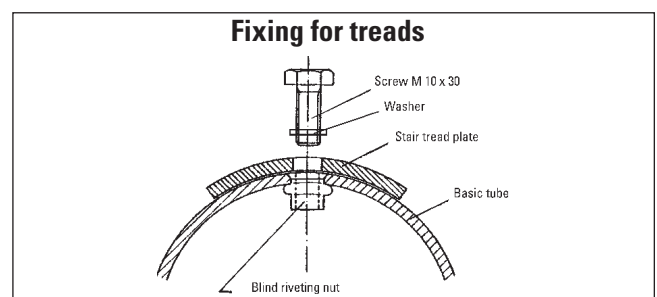
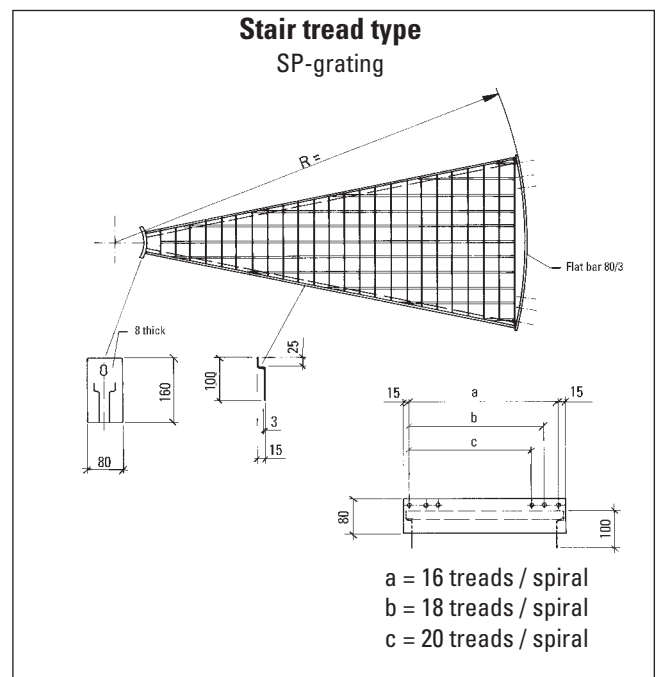
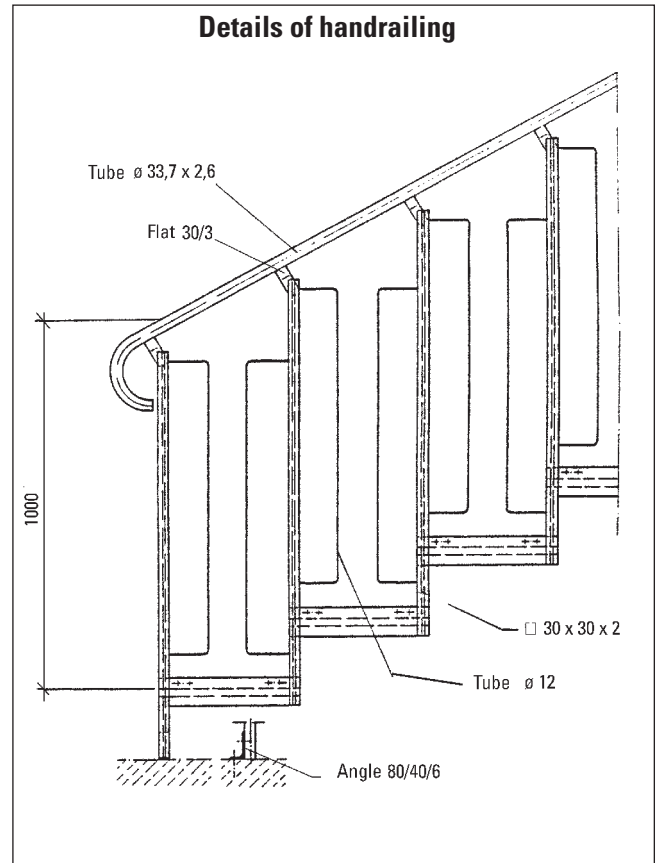
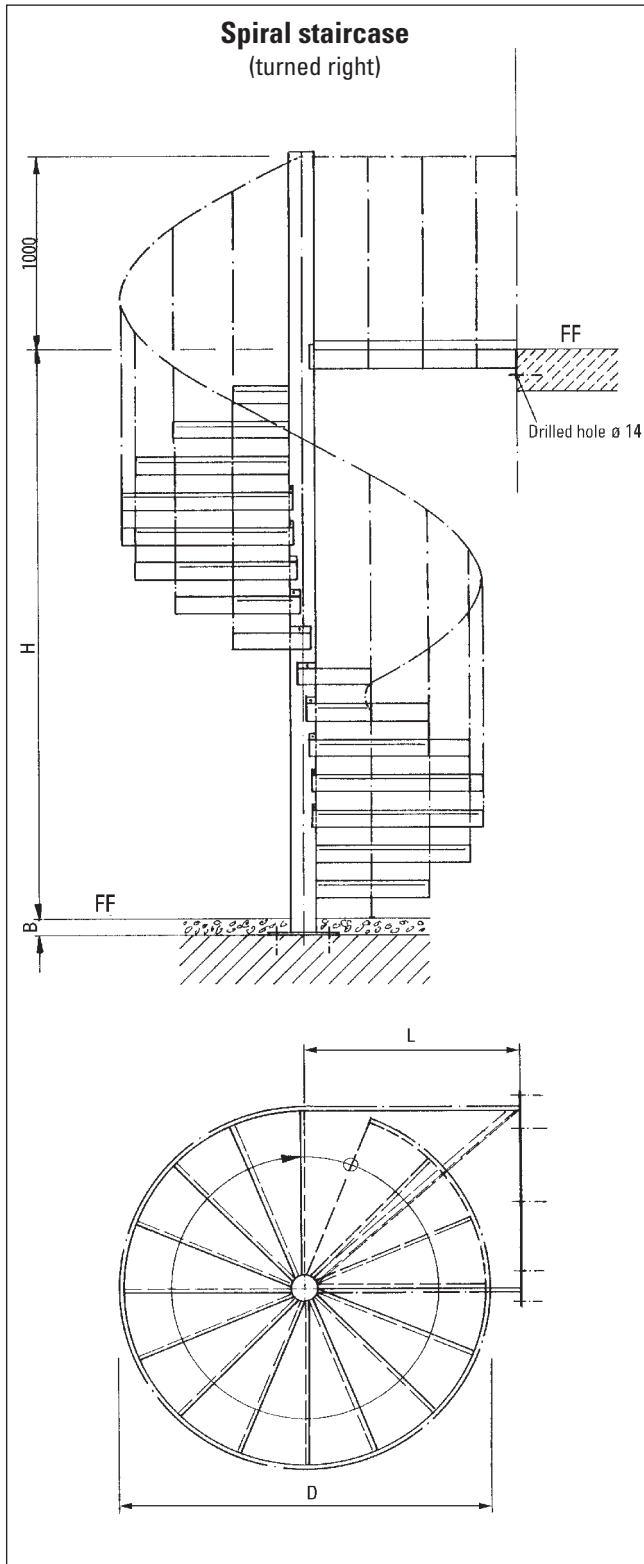

T Spiral Staircase „LG Standard“



Necessary data for spiral staircases type „LG Standard“

One complete spiral staircase in galvanised finish

Diameter of the staircase (D)		∅	_____	mm
Total height FF to FF (H)			_____	mm
Rise of steps			_____	mm
Height of hand railing			_____	mm
Number of stairtreads			_____	pce
Landing at exit (if possible please add your sketch)	dimension: _____		_____	pce
Intermediate landing	dimension: _____		_____	pce
Grating type	SP 225 - 34/38 - 3 (Standard)			
Basic tube including foot plate 200 x 200 x 8 and blind riveting nut, acc. to slope of stair tread linkage, one piece per stair tread concrete base level to finished floor level (B)		∅	_____	mm
			_____	mm

Specification for guarding:

Handrail fabricated out of 33,7 mm O.D. x 2,6 mm w.t. CHS, complete with fixing brackets. Each tread is supplied with a 30 x 30 x 2 mm special profile newel, complete with a slot on one side to facilitate fixing a screw at the tread position. Each newel has a shaped 12 mm diameter round bar welded to either one or both sides in order to reduce the maximum clear space between newels to either 120 mm or 180 mm.

T Guide for planning of Spiral Staircases

15 Treads / Spiral

ø 1500 - 1800 mm
Width of treads 225 - 270 mm

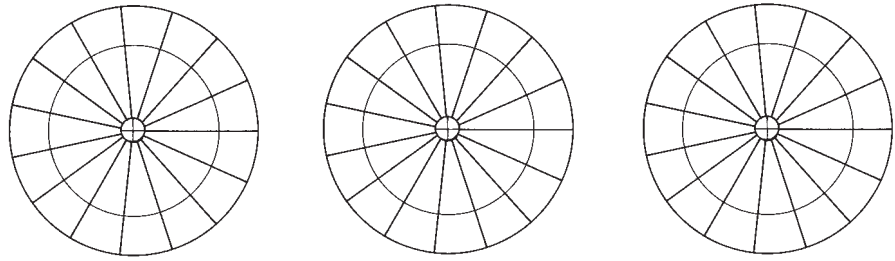

16 Treads / Spiral

ø 1700 - 2000 mm
Width of treads 235 - 280 mm

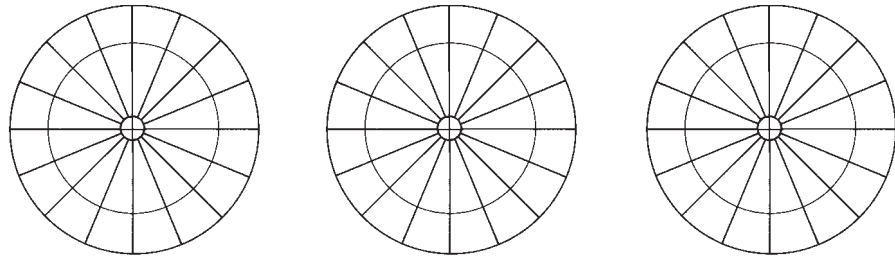

18 Treads / Spiral

ø 1900 - 2200 mm
Width of treads 235 - 270 mm

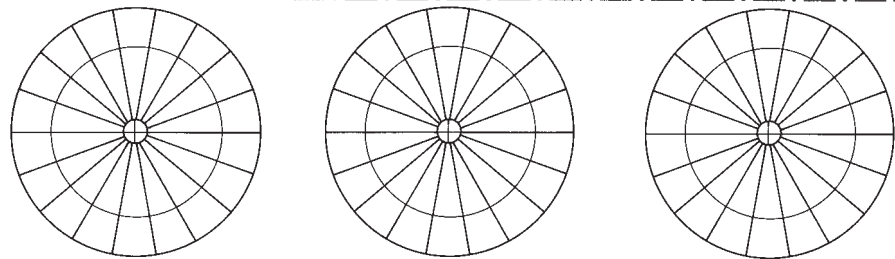

20 Treads / Spiral

ø 2100 - 2400 mm
Width of treads 235 - 270 mm

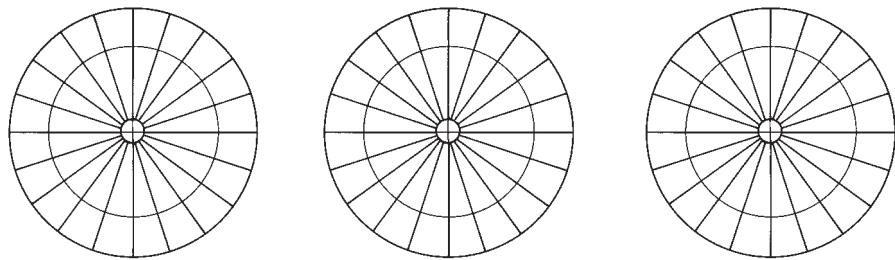

22 Treads / Spiral

ø 2300 - 2500 mm
Width of treads 230 - 250 mm

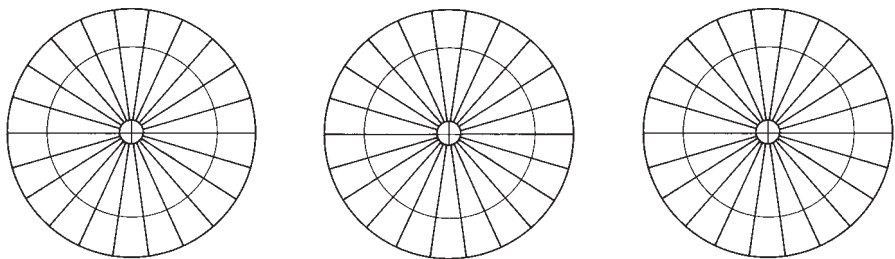

Landings - Examples of Layout

Stair turned left

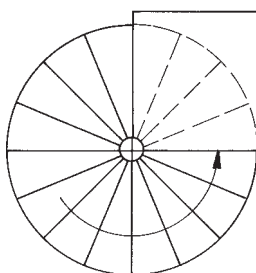

Stair turned right

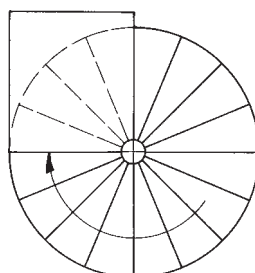

Stair turned left or right

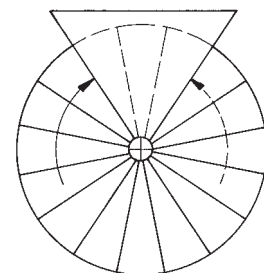

T Spiral Staircase „LG Special“

Spiral staircases type „LG Special“

in galvanised finish are developed in modular system for self-assembly. They are functional and reliable and suitable for many types of application.

Spiral staircases type „LG Special“ are produced with a maximum diameter of 2700 mm.

For areas accessible to the general public, guarding systems are fabricated with the maximum clear space distance between rail stanchions of 120 mm, whereas for industrial areas the maximum clear space distance is 180 mm.

The height of the handrail measured from the leading edge of the tread to the top of the handrail, should not be less than 1000 mm, except where the total height of the stair exceeds 12 m and then this distance should not be less than 1100 mm.

Calculations are carried out to determine the design requirements for staircases, by considering a uniformly distributed load of either 3,5 kN/sq.m., or a concentrated load of 1,5 kN applied over an area of 100 x 100 mm from the leading edge of the nosing, at a distance of 100 mm from the outside line of the stair.

Tread widths are supplied in accordance with the German Standard DIN 18065.



T Spiral Staircase „LG Special“



Spiral Staircases

T Spiral Staircase „LG Special“

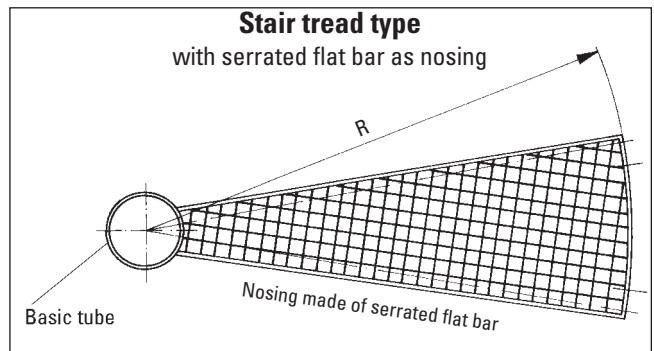
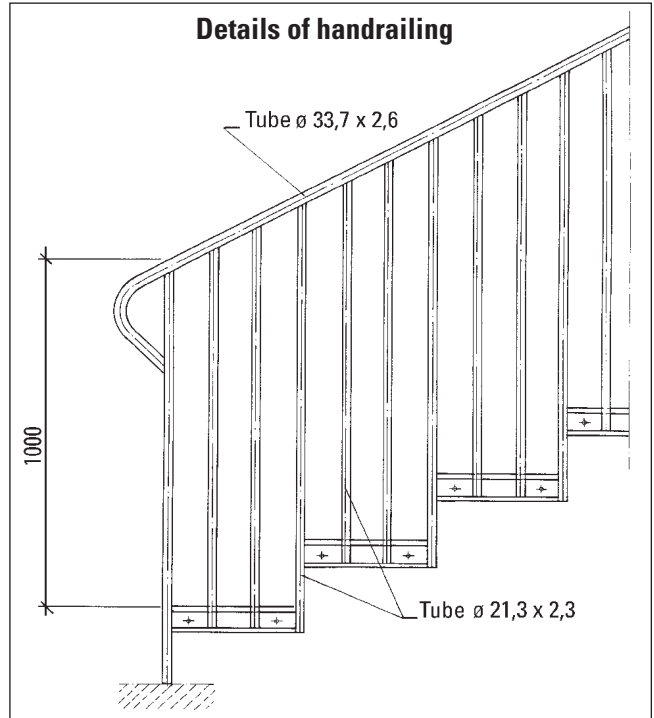
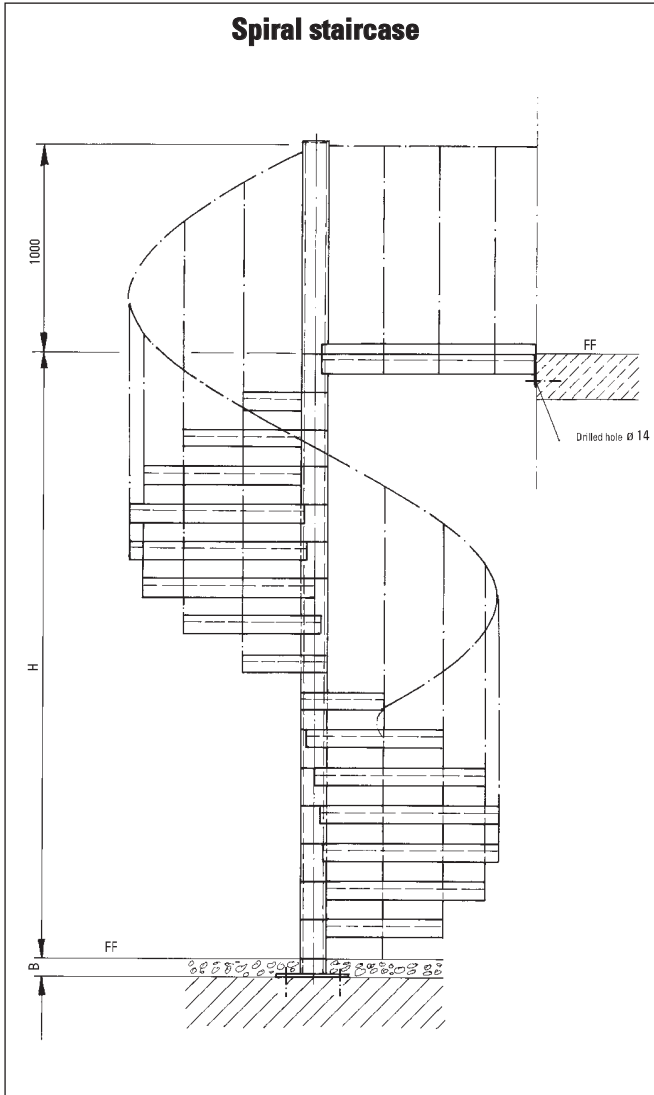

Necessary data for spiral staircases „LG Special“

One complete spiral staircase in galvanised finish

Diameter of the stair (D) Ø _____ mm

Total height FF to FF (H) _____ mm

Rise of steps _____ mm

Height of hand railing _____ mm

Number of stairtreads _____ pce

Landing at exit dimension: _____ _____ pce

(if possible please add your sketch)

Intermediate landing(s) dimension: _____ _____ pce

Grating type pressure-locked gratings or
forge-welded gratings type: _____

Basic tube including foot plate 300 x 300 x 10 Ø _____ mm

Concrete base level to finished level (B) _____ mm

Specification for guarding: Handrail fabricated out of 33,7 mm O.D. x 2,6 mm w.t. CHS
Newel fabricated out of 21,3 mm O.D. x 2,3 mm w.t. CHS
Max. clear space _____ mm
Including M10 screw x 30 mm long and nut



Serration

SP P B Serration

Metal gratings having members without serrated walking surfaces, generally have sufficient slip resistant properties for normal use in good environmental conditions. However, in locations where dirt, oil, grease, water or food increases the risk of slipping, there is the requirement for an improved slip resistant walking surface on floor coverings. This can be achieved by supplying either metal gratings with a series of notches or serrations in the top surfaces of bearing bars and/or cross bars or perforated metal planks having a series of raised pattern punched holes in the top surface.

In order to meet the different levels of

slip resistance required to suit a varying range of adverse conditions, several types of serrated top surfaces have been developed and are described below

SP Serration no. 1 and 11;

P Serration no. 2, 22, 3, 31, 32, 4 and 42;

B Serrated qualities because of surface specification

The Occupational Safety Authorities have determined criteria relating to serration. Instruction sheet BGR 181 refers to:

- working locations with an increased danger of skidding,
- the inspection procedure to find criteria for serration and
- the categories of the inspected floor coverings.

Regarding the description of types, we would refer to pages 15 (SP), 25 (P) and 43 to 45 (B).

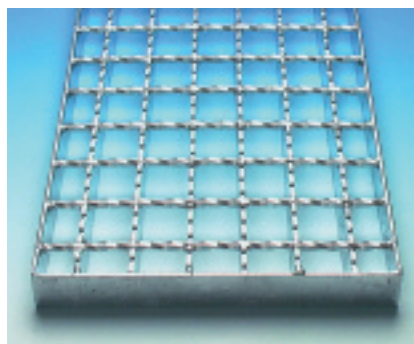

Grating XSP - type no. 1 / 11

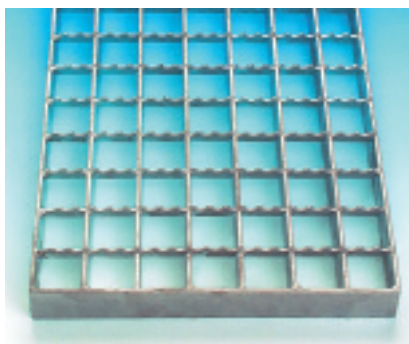

Grating XP - type no. 2

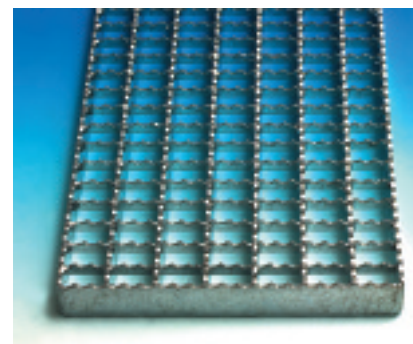

Grating XP - type no. 22

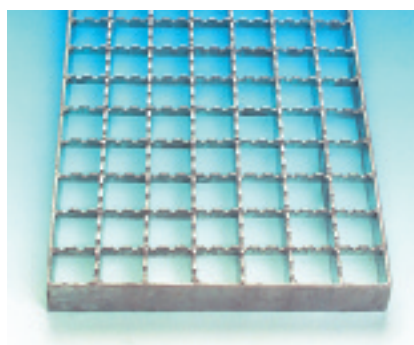

Grating XP - type no. 3 / 31

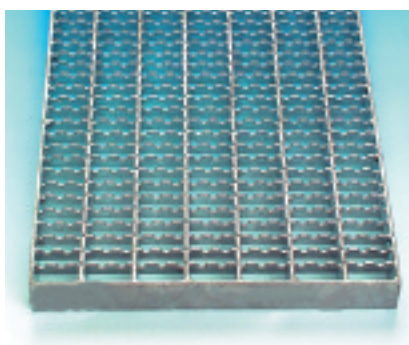

Grating XP - type no. 32

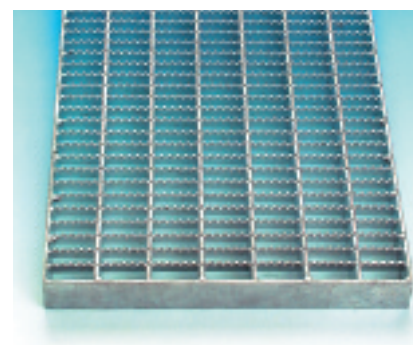

Grating XP - type no. 4 / 42

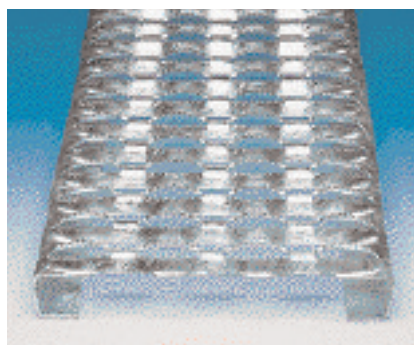

Perforated metal plank - type BZ

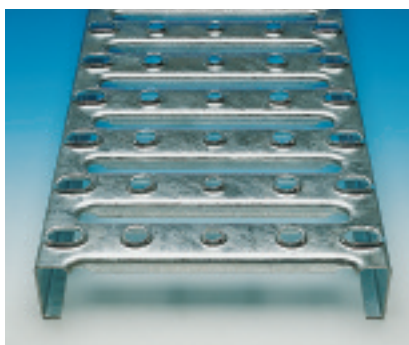

Perforated metal plank - type BP-Ü

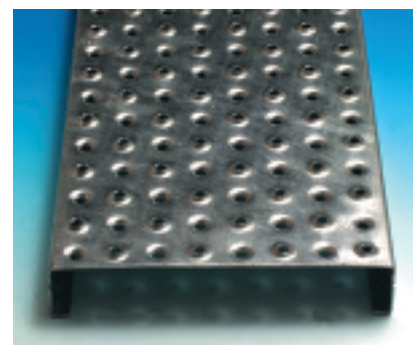

Perforated metal plank - type BN-0

Working rooms and working areas where there is a potential slipping hazard

Floor coverings in working rooms and working areas are collated under different categories according to the relative danger of skidding.

This procedure is based upon pedestrian traffic over the floor covering and tested on an inclined level. This test proves whether or not the floor covering is suitable for a specific work room.

The average angle of incline measurement, decides the coordination of the floor covering in one of the five serration classes. The serration class provides the scale for the degree of serration, therefore, coverings with serration class R 9 have the lowest and R 13 the highest requirements for serration.

Serration testing

Lichtgitter gratings and perforated metal planks have been tested by the Occupational Authorities and certificates confirming the test results are available upon request and are also published by the Occupational Authorities. In view of this, we are entitled to use a special sign (BG-Zeichen) for the products mentioned, to confirm our certification. Details of serration classes in terms of angles of inclination are shown in the following table.

Valuation categories for serration		
Total average value	Valuation category	
from 3° to 10°	R	9
more than 10° to 19°	R	10
more than 19° to 27°	R	11
more than 27° to 35°	R	12
more than 35°	R	13

The displacement of the tested products was certified in each case with V10.



Examples for necessary serration in working areas

Working rooms and areas	Serration class	Displacement
Production of margarine, cooking fat, salad-oil		
Production and packaging of margarine	R 12	
Production and packaging of cooking fat, bottling of salad-oil	R 12	
Treatment of milk and manufacturing of cheese		
Manufacturing, stocking and packaging of cheese	R 11	
Slaughter and treatment of meat		
Treatment of poultry	R 12	V 6
Department of cold meat and packaging	R 12	
Kitchens, dining rooms		
Kitchens for food-supply for residences, schools, kindergartens, hospitals	R 11	
Reheating kitchens	R 10	

Working rooms and areas	Serration class	Displacement
Chemical and thermal treatment of steel and metal		
Tempering shop	R 12	
Laboratory rooms	R 11	
Workshops for maintenance of aircrafts		
Airplane hangars	R 11	
Shipyards halls	R 12	
Washing bays	R 12	V 4
Installations for treatment of sewage		
Pump room	R 12	
Rooms for installations of sludge draining		
Computer rooms	R 12	
Wet areas for production of food and beverage		
Beverage filling	R11	
Fruit juice production		
Stock cellar, fermentation cellar	R 10	

SP P B Serration

Test results of serration (test certificates are available)

Type	Serration No. (*)	Surface treatment	Serration class	Displacement
Gratings out of steel				
SP 330-34/38-3	---	galvanised	R 10	V 10
P 330-33 -3	---	galvanised	R 10	V 10
P 230-33/11-3	---	galvanised	R 9	V 10
XSP 330-34/38-3	No. 1	galvanised	R 10	V 10
XSP 330-34/38-3	No. 11	galvanised	R 11	V 10
XP 230-33 -3	No. 2	galvanised	R 12	V 10
XP 230-33/22-3	No. 2	galvanised	R 12	V 10
XP 230-33/11-3	No. 2	galvanised	R 12	V 10
XP 230-33 -3	No. 22	galvanised	R 13	V 10
XP 330-33 -3	No. 22	galvanised	R 12	V 10
XP 330-33/22-3	No. 22	galvanised	R 12	V 10
XP 230-33 -3	No. 3	galvanised	R 11	V 10
XP 330-33 -3	No. 3	galvanised	R 11	V 10
XP 230-33 -3	No. 31	galvanised	R 12	V 10
XP 330-33 -3	No. 31	galvanised	R 12	V 10
XP 530-33 -5	No. 31	galvanised	R 11	V 10
XP 330-44 -3	No. 31	galvanised	R 12	V 10
XP 230-33/11-3	No. 32	galvanised	R 10	V 10
XP 230-33/11-3	No. 4 / 42	galvanised	R 11	V 10
XP 230-33 -3	No. 4	galvanised	R 11	V 10
XP 530-33 -5	No. 4	galvanised	R 11	V 10
Gratings out of stainless steel				
XP 225-33 -3	No. 3	pickled	R 12	V 10
XP 225-33 -3	No. 31	pickled	R 13	V 10
XP 225-33 -3	No. 31	pickled	R 13	V 10
XP 525-33 -5	No. 31	pickled	R 12	V 10
Gratings out of aluminum				
XP 225-33 -3	No. 3	pickled	R 13	V 10
XP 225-33 -3	No. 31	pickled	R 13	V 10
XP 225-33 -3	No. 4	pickled	R 13	V 10
Perforated metal planks out of steel				
BR 50/2		galvanised	R 11	V 10
BP 50/2		galvanised	R 11	V 10
BP-Ü 50/2		galvanised	R 12	V 10
BN-O 50/2		galvanised	R 11	V 10
BZ 50/2		galvanised	R 11	V 10
BN-G		galvanised, sanded with quartz	R 12	V 10
Perforated metal planks out of stainless steel				
BP 50/2		pickled	R 11	V 10
BN-O 50/2		pickled	R 11	V 10
BZ 50/2		pickled	R 12	V 10
Perforated metal planks out of aluminum				
BP 50/2		pickled	R 11	V 10
BN-O 50/2		pickled	R 13	V 10
BZ 50/2		pickled	R 13	V 10

* Notes regarding serration

- No. 1 endless punching of bearing bars
- No. 11 endless punching of bearing bars and cross bars deeper welded
- No. 2 endless punching of cross bars, peaked finish (distance between peaks: approx. 11 mm)
- No. 22 endless punching of bearing and cross bars, peaked finish (distance between peaks: approx. 11 mm)
- No. 3 punching of bearing bars and cross bars, with standard pitch 33,33 mm there are two cutouts within the pitch
- No. 31 endless punching of bearing and cross bars
- No. 32 endless punching of cross bars (qualified for guide dogs for the blind)
- No. 4 endless punching of cross bars; round off peaks at a distance of 5,5 mm

Prüf- und Zertifizierungsstelle
im BG-PRÜFZERT



BIA
Berufsgenossenschaftliches
Institut für Arbeitsschutz
Hauptverband der gewerblichen
Berufsgenossenschaften

BG-Prüfbescheinigung 970086
Bescheinigungs-Nummer

Name und Anschrift des
Bescheinigungsinhabers:
(Auftraggeber) Lichtgitter GmbH
Siemensstraße
48703 Stadthohn

Name und Anschrift des
Herstellers: Lichtgitter GmbH
Siemensstraße
48703 Stadthohn

Zeichen des Auftraggebers:
Bröcker Zeichen der Prüf- und Zertifizierungsstelle:
621.17-Mew/Wm/st. Ausstellungsdatum:
09.12.2003

Produktbezeichnung: Gitterroste aus Stahl S 235 JR, verzinkt

Typ: Pressrost, Nr. 3: XP 330-33-3
Trag- und Querstab mit halbrunden Ausnehmungen unterbrochen

Bestimmungsgemäße
Verwendung: Fußbodenbelag für den Einsatz in Arbeitsräumen und Arbeitsbereichen
mit Rutschgefahr, in denen Bodenbeläge der Bewertungsgruppe R11/V10
gefordert werden.

Prüfgrundlage: BGR 181 (bisher ZH1/571) (10.93) Aktualisierte Fassung 10.2003 und
DIN 51 130 (11.92)

Zugehöriger Prüfbericht: Prüfzeugnis-Nr.: 200323745/3210 - BIA, Sankt Augustin

Bemerkungen: Das BG-PRÜFZERT-Zeichen ist nur in Verbindung mit einem Hinweis auf die
Bewertungsgruppen für Rutschhemmung und Vordrängungsraum zu verwenden.
**Diese BG-Prüfbescheinigung ersetzt die Bescheinigung
mit gleicher Nummer vom 04.11.97**

Das geprüfte Baumuster entspricht den zur Zeit geltenden Sicherheits- und Gesundheitsanforderungen in der
Bundesrepublik Deutschland.
Der Bescheinigungsinhaber ist berechtigt, das uneinseitig abgebildete BG-PRÜFZERT-Zeichen an den mit dem geprüften
Baumuster übereinstimmenden Produkten anzubringen, und zwar mit dem unter 'Bemerkungen' genannten Hinweis.
Diese Bescheinigung wird spätestens ungültig am: 31.12.2008

Weiters über die Gültigkeit, eine Gültigkeitsverlängerung und andere Bedingungen regelt die Prüf- und Zertifizierungsordnung
vom Oktober 1997.

Leiter der Zertifizierungsstelle Fachzertifizierer
Prof. Dr.-rer. nat. Diemar Reinert *Dr.-Ing. Detlef Mewes*

Postadresse: Hausadresse: Telefon: 0 22 41/2 31-02
53754 Sankt Augustin 53757 Sankt Augustin Telefax: 0 22 41/2 31-22 34

FB87D
07 03

Reduction of load bearing capacity on gratings

In order to increase levels of slip resistance, bars are serrated by punching out material from the walking surface. Due to this reduction in material, the load values stated in the load tables for non serrated walking surfaces need to be reduced proportionately. The load bearing capacity of serrated grating types no. 1, no. 3 and no. 31 is reduced by approx. 24% for forge-welded gratings and pressure-locked gratings having 20 x 2 mm bearing bars and by approx. 9% for 60 x 5 mm bearing bars, compared to the values shown on pages 16 & 17 and 26 & 27. At the reduced loading on 20 x 2 mm bearing bars, the deflection is approx. 17% greater and on 60 x 5 mm bearing bars, it is approx. 4% greater.

Walkways having inclines between 6° and 24°

The supply of standard gratings is recommended for walkways to conveyors or similar installations, when they are inclined up to 6°. Walkways inclined from 6° to 10° should be provided with serrated gratings. At an angle of inclination between 10° and 24°, metal gratings should be supplied with an anti-slip metal strip securely fixed to the top surface, at various pitches*, over the whole length of the grating (e.g. U20/20/20/2.0). For angles of incline in excess of 24°, stairs should be used.

* The pitch of anti-slip strips is to be determined from the formula used for stair design, which is $600 \leq g + 2h \leq 660$, where g = the stair tread 'going' and h = the height determined from the angle of incline.

Prüf- und Zertifizierungsstelle
im BG-PRÜFZERT



BIA
Berufsgenossenschaftliches
Institut für Arbeitsschutz
Hauptverband der gewerblichen
Berufsgenossenschaften

BG-Prüfbescheinigung 0304054
Bescheinigungs-Nummer

Name und Anschrift des
Bescheinigungsinhabers:
(Auftraggeber) Lichtgitter GmbH
Siemensstraße
48703 Stadthohn

Name und Anschrift des
Herstellers: Lichtgitter GmbH
Siemensstraße
48703 Stadthohn

Zeichen des Auftraggebers:
Bröcker Zeichen der Prüf- und Zertifizierungsstelle:
521.17-Mew/Wm/st. Ausstellungsdatum:
12.12.2003

Produktbezeichnung: Blechprofilroste aus Stahl S 235 JR, sendzimirverzinkt

Typ: Zahn BZ 50/2

Bestimmungsgemäße
Verwendung: Fußbodenbelag für den Einsatz in Arbeitsräumen und Arbeitsbereichen
mit Rutschgefahr, in denen Bodenbeläge der Bewertungsgruppe R13/V10
gefordert werden.

Prüfgrundlage: BGR 181 (bisher ZH1/571) (10.93) Aktualisierte Fassung 10.2003 und
DIN 51 130 (11.92)

Zugehöriger Prüfbericht: Prüfzeugnis-Nr.: 200323778/3210 - BIA, Sankt Augustin

Bemerkungen: Das BG-PRÜFZERT-Zeichen ist nur in Verbindung mit einem Hinweis auf die
Bewertungsgruppen für Rutschhemmung und Vordrängungsraum zu verwenden.

Das geprüfte Baumuster entspricht den zur Zeit geltenden Sicherheits- und Gesundheitsanforderungen in der
Bundesrepublik Deutschland.
Der Bescheinigungsinhaber ist berechtigt, das uneinseitig abgebildete BG-PRÜFZERT-Zeichen an den mit dem geprüften
Baumuster übereinstimmenden Produkten anzubringen, und zwar mit dem unter 'Bemerkungen' genannten Hinweis.
Diese Bescheinigung wird spätestens ungültig am: 31.12.2008

Weiters über die Gültigkeit, eine Gültigkeitsverlängerung und andere Bedingungen regelt die Prüf- und Zertifizierungsordnung
vom Oktober 1997.

Leiter der Zertifizierungsstelle Fachzertifizierer
Prof. Dr.-rer. nat. Diemar Reinert *Dr.-Ing. Detlef Mewes*

Postadresse: Hausadresse: Telefon: 0 22 41/2 31-02
53754 Sankt Augustin 53757 Sankt Augustin Telefax: 0 22 41/2 31-22 34

FB87D
07 03

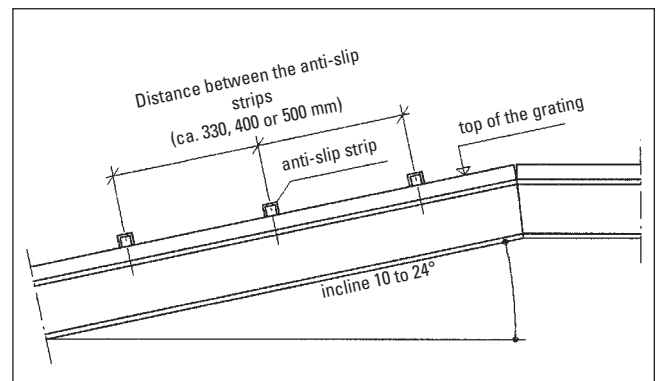

Serration

Surface treatment



The preferred surface treatment of Lichtgitter products made out of steel is galvanising according to DIN EN ISO 1461. Having our own galvanising plants within the group, we are able to achieve a high level of productivity, and therefore ensure price advantages as well as consistent quality and short delivery terms.

We are fully responsible for the environment within our galvanising plants and therefore environmental protection during the galvanising process is of utmost priority.

At our head office in Stadtlohn we have built a galvanising plant, which is in line with the latest state of the art for the galvanising industry and thereby ensures maximum environmental protection.

Areas where acid or chemical are used are completely closed off. This ensures that working areas are free of emission and clean working conditions are achieved.

The galvanising plant conserves energy, minimises waste and any emissions fall well below the predicted EU Standard

emission values.

All remnants are re-used, the level of energy re-use is up to 96% due to heat recovery and being a captive system, the accumulation of dross is not a problem.

In this way, Lichtgitter's ideas about quality and service are fully realised. We strongly believe in offering high quality, excellent service and efficient logistics, to consistently meet the requirements of our clients, particularly within the galvanising process.



Surface Treatment



1. Surface treatment for steel gratings and steel for construction applications, in accordance with to DIN EN 10025

- 1.1 Galvanising acc. to DIN EN ISO 1461 (hot dip galvanised)
- 1.2 Galvanising followed by bitumen dipping
- 1.3 Plastic coating *, also galvanised surfaces (colours according to RAL)
- 1.4 Baked paint *, also on galvanised surfaces (colours according to RAL)

2. Gratings and perforated metal planks made of stainless steel, material acc. to DIN 17440

- 2.1 Pickled
- 2.2 Electrochemically polished
- 2.3 Glass bead blasting

3. Gratings and perforated metal planks from aluminum material acc. to DIN EN 485 and DIN EN 573

- 3.1 Pickled
- 3.2 Baked paint * (colours according to RAL)
- 3.3 Anodised
- 3.4 Plastic coating * (colours according to RAL)

Gratings and perforated metal planks receive a surface protection to avoid potential corrosion.

Gratings manufactured from stainless steel and aluminum generally do not need a corrosion protection. At least one after-treatment by pickling (see 2.1/3.1) or anodising (see 3.3) is recommended.

Hot dip galvanising

(usual corrosion protection for gratings)
The term „hot dip galvanising“ means the adding of a zinc finish by dipping the pre-treated parts into a molten zinc dip (see photo).

The zinc coat adheres firmly to surfaces. In case of normal mechanical demands such as transportation, pedestrian or vehicle traffic, zinc does not flake off or develop cracks.

The average weight of the zinc coating is approximately 450 g per sqm of treated surface. This corresponds to a coating thickness of approximately 65 µm. The thickness of the zinc coating also depends on the thickness of the material (see list on page 81). Before galvanising, parts are pre-treated to provide a mechanically clean surface in order to achieve a faultless adherence of zinc.

Bitumen dipping

is often requested as an additional treatment for galvanised gratings, and gives extra surface protection (mainly for chemical use).

Plastic coatings

Plastic coatings are achieved, e.g. by dipping or electrostatic powder coating. The abrasion resistance and thickness of finish required, depends upon the application, so this needs to be considered when deciding which procedure and plastic to use.

Painting

Gratings and perforated metal planks can likewise be lacquered in a dipping or spraying process, preferably after galvanising.

* A coating with epoxy resin powder for outside areas is not recommended. For these areas, a polyester powder coating should be used.



Extract from DIN EN ISO 1461

Appendix A.2

A coating of hot dip galvanising is denoted: t Zn, where t is short for 'thermal', e.g.

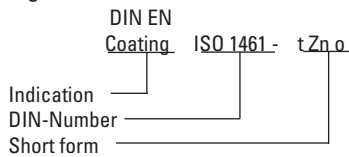

The short form t Zn o denotes, hot dip galvanising where o indicates no after-treatment.

Another term used under DIN EN ISO 1461 is when a coating is required as an after-treatment, e.g., t Zn b. This term denotes, hot dip galvanising where b indicates an after-treatment. When parts

are supplied with painted surfaces (t Zn b), the coating is carried out after galvanising.

6.1 Appearance

During visual quality inspections, all essential areas of the galvanised parts have to be free of enlargements/bubbles, roughness, zinc peaks and defects. The meanings of „roughness“ and „smoothness“ are relative. Therefore, roughness of partly galvanised coatings is different to that of continuous galvanised parts.

The appearance of dark or light grey areas (e.g., a network structure of grey areas), white rust, or slight unimportant

surface unevenness is not really a problem, providing the minimum value of the zinc coating thickness is still achieved. White rust or staining predominantly consisting of zinc oxide, usually occurs with light or dark corrosion items, when stocking hot dip galvanised products in humid conditions.

6.2 Coating thickness

The thickness of zinc coating should be conform to the values stated in the following table. Deviations on these thicknesses are permitted but should be agreed separately.

The inspection of the coating thickness is normally carried out in accordance with the requirements of DIN EN ISO 2178. In this case, the measured area is relatively small and some of the individual values may be lower than the values of the local or average coating thickness. A sufficient number of measurements within a reference area are to be obtained by using magnetic tests or graphic methods, in order to achieve the required local thickness.

Table: Coating thickness

Material thickness (mm)	Local coating thickness minimum value in μm	Average coating thickness minimum value in μm
Steel parts with thickness < 1,5 mm	35	45
Steel parts with thickness $\geq 1,5$ mm to < 3 mm	45	55
Steel parts with thickness ≥ 3 mm to < 6 mm	55	70
Steel parts with thickness > 6 mm	70	85

Thicker zinc coatings or other additional requirements can be provided, without contravening the requirements to this standard.

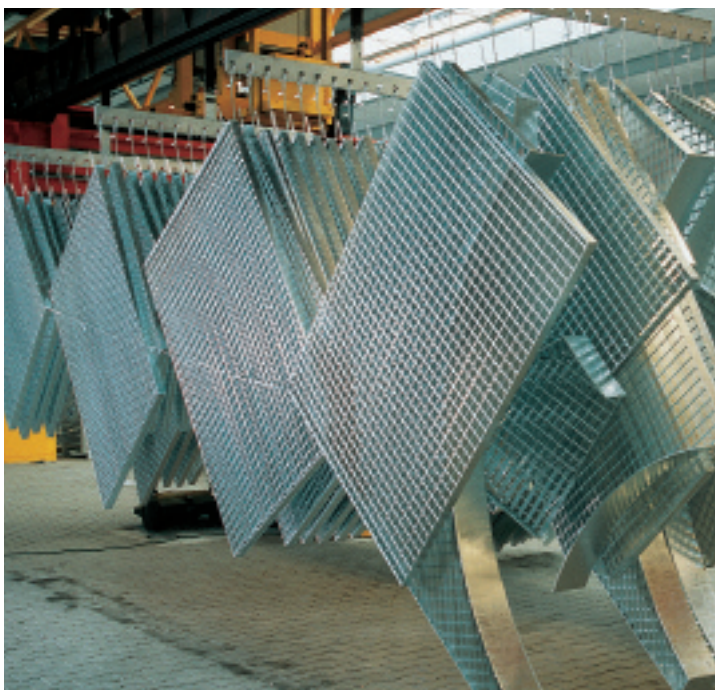

6.3. Repairing

The total area of all individual areas without coating that needs to be restored, shall not exceed 0,5% of the total surface area and the maximum size of a single area without coating shall not exceed 10 cm².

The repairing process should include the removal of dirt and the necessary cleaning and surface pre-treatment required, to ensure complete adherence.

The coating thickness of any repaired area should be at least 30 μm more than the required local coating thickness shown in the table.

SP P B Tolerances

Gratings and perforated metal planks are subject to fixed production and delivery tolerances. Details of these tolerances can be found in **RAL-GZ 638** for gratings and **RAL-GZ 639** for perforated metal planks.

Details regarding gratings are restricted to the following:

- bearing bars $\leq 60 \text{ mm} \times 5 \text{ mm}$
- 66,66 mm maximum bearing bar pitch
- 11,11 mm minimum cross bar pitch
- 2,0 sq.m. maximum area of grating, whereby a side dimension should not be greater than 2000 mm

Tolerances for other Lichtgitter grating types are available upon request.

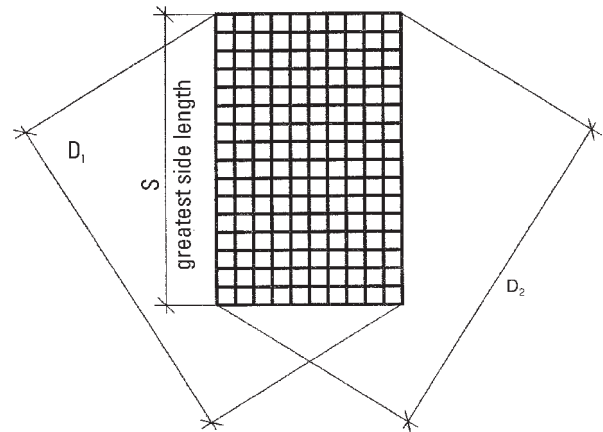

The difference between the measured diagonals D_1 and D_2 shall not exceed $0,010 \times s$, where s is the greatest side dimension.

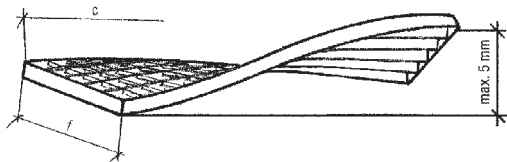
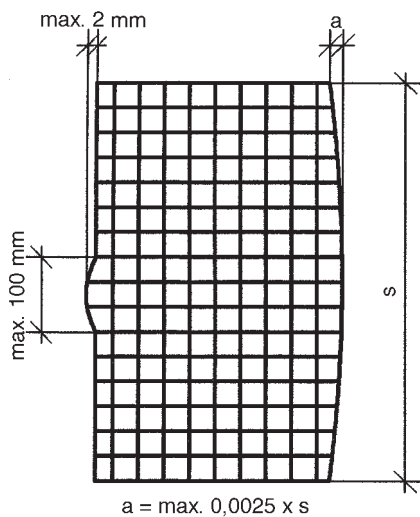

Torsion (deviation of surface evenness) within the grating. Deviation is permissible to a maximum of 5 mm; with gratings ca. 300 x 300 mm maximum approximately 2 mm.

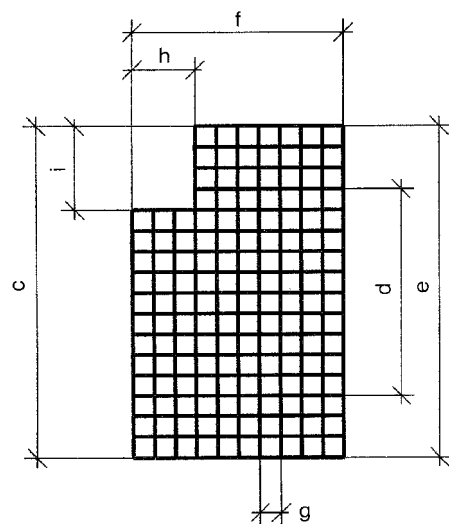

Maximum Tolerances

Length & width

Dimensions c ; e ; f = $+0 \text{ mm} / -4 \text{ mm}$

Pitches

Dimension g = $\pm 1,5 \text{ mm}$

Dimension d = $\pm 4 \text{ mm}$
(measured over 10 pitches)

Cutouts

dimension h ; i = $+8 / -0 \text{ mm}$

Tolerances (deformations) under loaded conditions are not included.

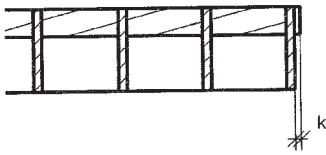

Outstanding cross bar or binding bar
(for pressure-locked gratings as well)
k max. = 0,5 mm

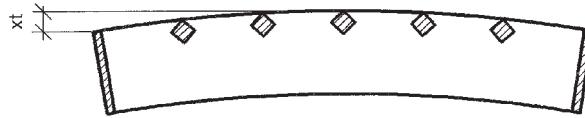

Convex deviation xt max. = 1/150th of length
for dimensions > 450 mm; max. 8 mm
smaller dimensions than 450 mm; max. 3 mm

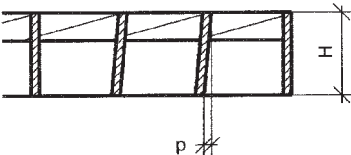

Inclination of bearing bars and binding bars
p max. = 0,1 x H
but max. 3 mm

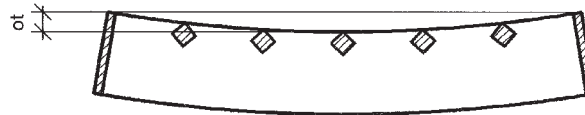

Concave deviation ot max. = 1/200th of length
for dimensions > 600 mm; max. 8 mm
smaller dimensions than 600 mm; max. 3 mm

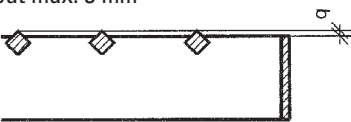

Upstanding cross bar
q max. = 1,5 mm

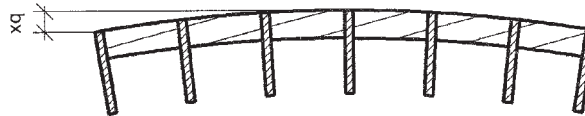

Convex deviation xq max. = 1/150th of width
for dimensions > 450 mm; max. 8 mm
smaller dimensions than 450 mm; max. 3 mm



Upstanding binding bar
s max. = 1,0 mm

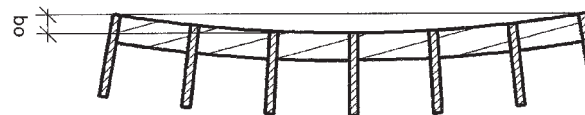

Concave deviation oq max. = 1/200th of width
for dimensions > 600 mm; max. 8 mm
smaller dimensions than 600 mm; max. 3 mm

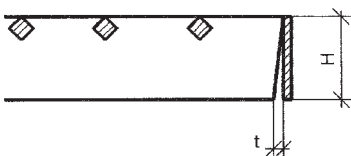

Lower projecting binding bar
r max. = 1,0 mm

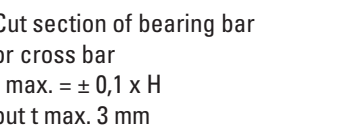

Cut section of bearing bar
or cross bar
t max. = ± 0,1 x H
but t max. 3 mm

P Tolerances

Tolerances (deformations) under loaded conditions are not included

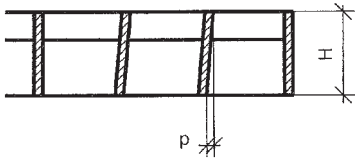

Inclination of bearing bars and binding bars
 p max. = $0,1 \times H$
 but max. 3 mm

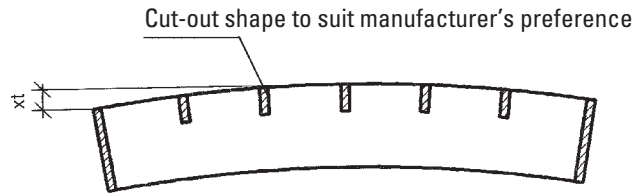

Convex deviation xt max. = $1/200^{\text{th}}$ of length
 for dimensions > 450 mm; max. 8 mm
 smaller dimensions than 450 mm; max. 3 mm

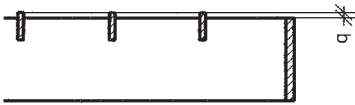

Upstanding cross bar
 q max. = 1,5 mm



Concave deviation ot max. = $1/200^{\text{th}}$ of length
 for dimensions > 600 mm; max. 8 mm
 smaller dimensions than 600 mm; max. 3 mm



Upstanding binding bar
 s max. = 1,0 mm

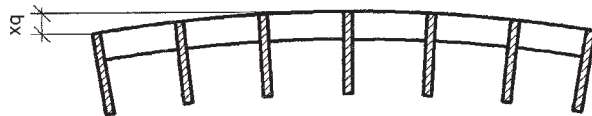

Convex deviation xq max. = $1/200^{\text{th}}$ of width
 for dimensions > 450 mm; max. 8 mm
 smaller dimensions than 450 mm; max. 3 mm

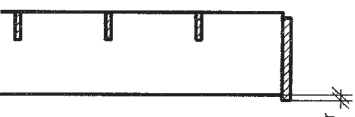

Lower projecting binding bar
 r max. = 1,0 mm

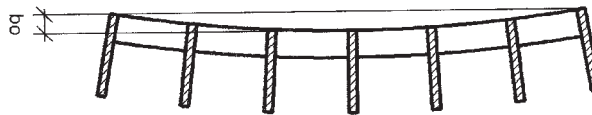

Concave deviation oq max. = $1/200^{\text{th}}$ of width
 for dimensions > 600 mm; max. 8 mm
 smaller dimensions than 600 mm; max. 3 mm

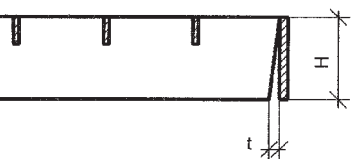

Cut section of bearing bar
 or cross bar
 t max. = $\pm 0,1 \times H$
 but max. 3 mm

Tolerances (deformations) under loaded conditions are not included

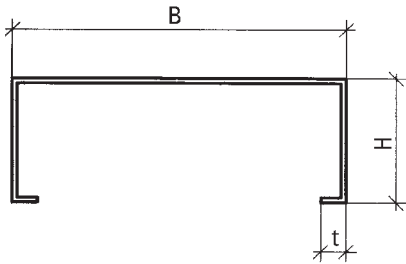

Element width $B = +2,0 \text{ mm}; -2,0 \text{ mm}$
 Element height $H = +1,5 \text{ mm}; -1,5 \text{ mm}$
 Rim $t = \text{min. } 10 \text{ mm}$

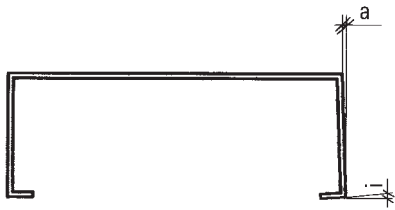

Inclination
 outwards $a = 0,05 \times H$
 rim $i = \text{max. } 2,5 \text{ mm}$

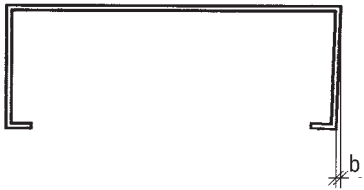

Inclination
 inwards $b = 0,05 \times H$

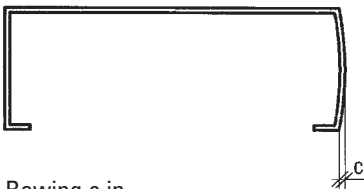

Bowing c in
 direction $H = 0,05 \times H$



Bowing d in
 direction $B = 0,015 \times B$



Bowing e (deflection) in
 direction $B = 0,015 \times B$

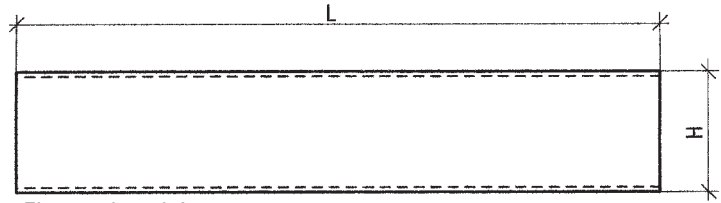

Element length $L = +2,0 \text{ mm}; -4,0 \text{ mm}$
 Element height $H = +2,0 \text{ mm}; -4,0 \text{ mm}$

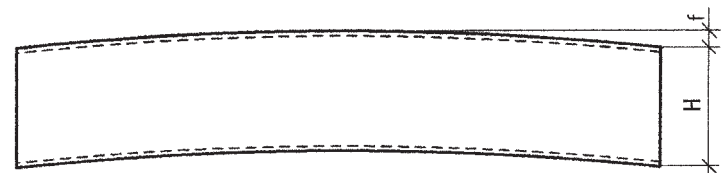

Bowing f in direction $L = 0,004 \times L$

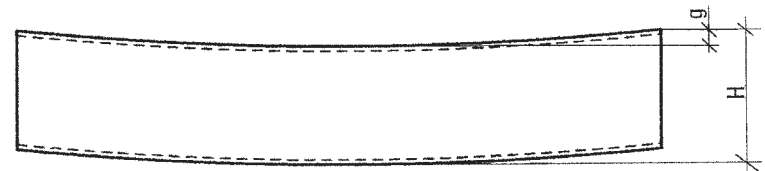

Bowing g in direction $L = 0,002 \times L$

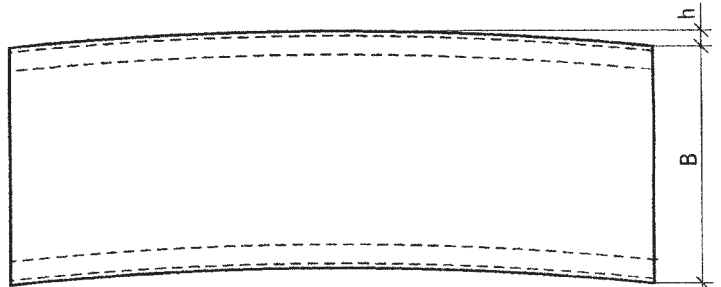

Lateral horizontal deviation $h = 0,002 \times L$

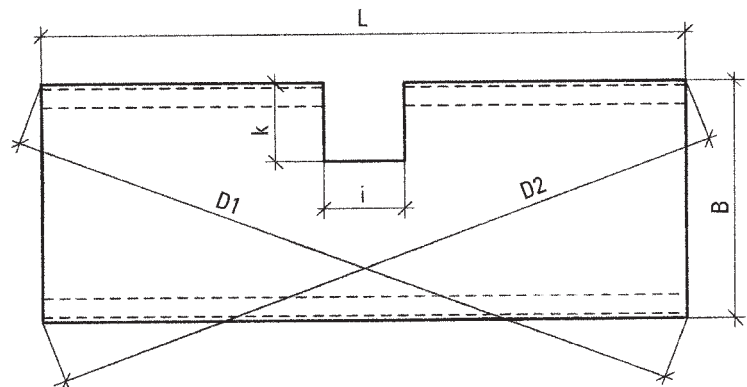

Max. diagonal deviation between $D1$ & $D2 = \text{max. } 0,005 \times L$
 Cutout dimensions $i; k = +8,0 \text{ mm}; -0,0 \text{ mm}$

Spans should be considered as being the clear distance between supports, when carrying out static load calculations.

The permissible stress level and 'E' value for the appropriate material being considered should be used in calculations and the worst case loading should be determined by considering concentrated loads applied in the most unfavourable position.

Calculation of moments of resistance (strength) and moments of inertia

- a) Forge-welded gratings
The section modulus 'W' and moment of inertia 'I' should be determined by considering bearing bar sizes without a zinc coating, or a reduction factor unless the bearing bars are serrated.
- b) Pressure-locked gratings
The section modulus 'W' and moment of inertia 'I' should be determined by considering bearing bar sizes without a zinc coating, but with a reduction factor 'v' of 0,9 to reflect the weakening effect consistent with pressure-locked gratings, even when galvanised.
- c) The section modulus 'W' and moment of inertia 'I' for perforated metal planks should be determined as for forge-welded gratings, but without any reduction factor.

Perforated metal planks

When calculating the moments of inertia and resistance for perforated metal planks, any curve and the rim radius can be ignored. Calculation of the profile in rectangular form is permitted providing the plank t_0 is considered up to the first perforation.

All types, with plank profiles running in direction B, can be calculated in this way and an increase in the load carrying capability can be achieved by screwing the elements together

Various types of plank without profiled bridges running in the direction of „B“, are considered suitable for pedestrian use when the thickness of sheets and widths of planks, are constructed as follows:

Thickness of sheets in mm	width of planks in mm
2,0	200
2,5	250
3,0	300

When calculating the moments of inertia and resistance of metal planks without perforation, the complete width 'B' of each plank should be considered.

Table 1

Number of additional bearing bars considered to carry a concentrated load applied over an area of 200 x 200 mm, due to distribution of the load to adjacent bars, via cross bars.

bearing bar height	distribution to adjacent bars, via the cross bars	
	forge-welded gratings pitch 34 x 38 mm	pressure-locked gratings pitch 33 x 33 mm
20	2,25	3,33
25	2,19	3,25
30	2,13	3,17
35	2,06	3,08
40	2,00	3,00
50	1,88	2,83
60	1,75	2,67
70	1,63	2,50
80	1,50	2,33
90	-	2,17
100	-	2,00

If the actual pitch for the grating being considered is different from the pitch shown in the table, then the figures shown for 'm' may be different and should therefore be considered.

Key to symbols

- W = section modulus [cm³]
- I = moment of inertia [cm⁴]
- e = greatest distance between the centre of gravity and the exterior fibre, i.e., extreme fibre distance
- M max. = maximum bending moment [kNcm]
- m = number of load-carrying bearing bars (due to load distribution of cross bars)
- n = actual number of bearing bars under load
- n₁ = actual number of loaded elements
- n₂ = actual number of loaded planks
- f = deflection under load in cm
- E = modulus of elasticity [kN/cm²]
- σ = maximum stress [kN/cm²]
- v = reduction factor for pressure-locked gratings
- F_v = uniformly distributed load [kN/m²]
- F_p = concentrated load on load area[kN]
- A = area [m²]
- t = bearing bar pitch [cm] or pitch of planks [cm]
- b_T = load extent in bearing bar direction [cm]
- b_V = load extent in cross bar direction [cm]
- B = element width
- b_L = load extent in direction L
- b_B = load extent in direction B
- H = height [cm]
- b = thickness of bar [cm]
- h = height of bar [cm]
- L = clear span [cm]
- L₁ = B
- ↔ = bearing bar direction

Formula table

	SP P	B
Determination of center of gravity		$x_s = \frac{A_1 \cdot x_1 + A_2 \cdot x_2 + A_3 \cdot x_3}{A_1 + A_2 + A_3}$
Formula „Steiner“		$I_{x1} = I + A \cdot a^2$
Inertia moment	$I = \frac{b \cdot h^3}{12} \text{ [cm}^4\text{]}$	$I_{xtotal} = I_{x1} + I_{x2} + \dots$
	$I_{real} = \frac{b \cdot h^3}{12} \cdot n \cdot v \text{ [cm}^4\text{]}$	$I_{real} = \frac{b \cdot h^3}{12} \cdot n \text{ [cm}^4\text{]} = I_x \cdot n_1(n_2)$
Section modulus	$W = \frac{b \cdot h^2}{6} \text{ [cm}^3\text{]}$	$W = \frac{b \cdot h^2}{6} \text{ [cm}^3\text{]} = \frac{I_{xtotal}}{e}$
	$W_{real} = \frac{b \cdot h^2}{6} \cdot n \cdot v \text{ [cm}^3\text{]}$	$W_{real} = \frac{b \cdot h^2}{6} \cdot n \text{ [cm}^3\text{]}$
Number of bearing bars to consider	$n = \frac{A}{L \cdot t}$ at distributed load $n = \frac{\text{load width}}{\text{bearing bar pitch}} + m$ (for point load)	
Number of loaded elements		$n_1 = \frac{A}{L_1 \cdot B}$
Number of loaded planks		$n_2 = \frac{b_L}{t}$
Maximum bending moment	$\max.M = \frac{F_v \cdot L^2}{8} \text{ [kNcm]}$ at distributed load	$\max.M = \frac{F_v \cdot L^2}{8} \text{ [kNcm]}$ at distributed load
	$\max.M = \frac{F_p \cdot (L - \frac{b^*}{2})}{4} \text{ [kNcm]}$ at point load $b^* = b_T \text{ resp. } b_V$	$\max.M = \frac{F_p \cdot (L - \frac{b^*}{2})}{4} \text{ [kNcm]}$ at point load $b^* = b_L \text{ resp. } b_B$
Stress / Sigma	$\sigma = \frac{\max.M}{W_{real}} \text{ [kN/cm}^2\text{]}$	$\sigma = \frac{\max.M}{W_{real}} \text{ [kN/cm}^2\text{]}$
Deflection	$f = \frac{5 \cdot F_v \cdot L^3}{384 \cdot E \cdot I_{real}} \text{ [cm]}$ at distributed load	$f = \frac{5 \cdot F_v \cdot L^3}{384 \cdot E \cdot I_{real}} \text{ [cm]}$ at distributed load
	$f = \frac{F_p}{384 \cdot E \cdot I_{real}} (8L^3 - 4L \cdot b_T^2 + b_T^3) \text{ [cm]}$ at point load	$f = \frac{F_p}{384 \cdot E \cdot I_{real}} (8L^3 - 4L \cdot b^2 + b^3) \text{ [cm]}$ at point load $b^* = b_L \text{ bzw. } b_B$

SP Static Calculations

Calculation example 1: Forge-welded grating

Wheel load	50 kN
Contact area acc. to DIN 1072	20 x 40 mm
Clear span	68 cm
Bearing bar pitch	3,43 cm
Cross bar pitch	3,81 cm

Load arrangement 1

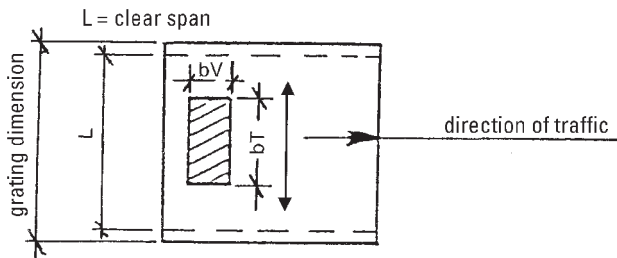

$$\max. M = \frac{F_p \left(L - \frac{bT}{2} \right)}{4} = \frac{50 \left(68 - \frac{40}{2} \right)}{4} = 600 \text{ kNcm}$$

chosen: bearing bar $\phi 80 \times 5 \text{ mm}$

$$n = \frac{bV}{t} + m = \frac{20}{3,43} + 1,5 = 7,33 \text{ bars}$$

$$W_{\text{real}} = \frac{b \times h^2}{6} \times n = \frac{0,5 \times 8^2}{6} \times 7,33 = 39,09 \text{ cm}^3$$

$$\sigma = \frac{\max. M}{W_{\text{real}}} = \frac{600}{39,09} = 15,35 \text{ kN/cm}^2 < 16,0 \text{ kN/cm}^2$$

deflection

$$f = \frac{F_p}{384 \times E \times I_{\text{real}}} (8L^3 - 4L \times bT^2 + bT^3)$$

$$f = \frac{50}{384 \times 2,1 \times 10^4 \left(\frac{0,5 \times 8^3}{12} \times 7,33 \right)} (8 \times 68^3 - 4 \times 68 \times 40^2 + 40^3)$$

$$f = 0,09 \text{ cm} = \frac{1}{755} \text{ of clear span} < L/200$$

Load arrangement 2

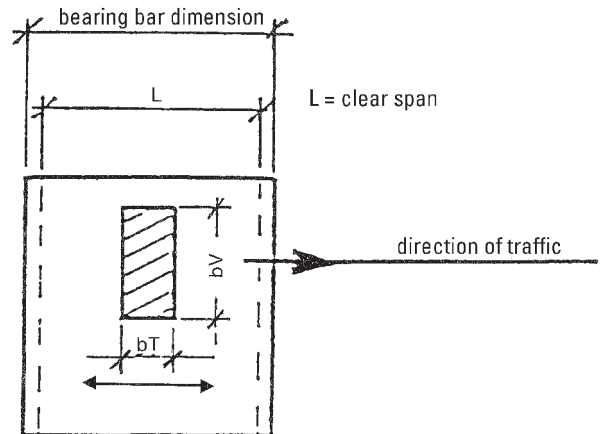

$$\max. M = \frac{F_p \left(L - \frac{bT}{2} \right)}{4} = \frac{50 \left(68 - \frac{20}{2} \right)}{4} = 725 \text{ kNcm}$$

chosen: bearing bar $\phi 80 \times 5 \text{ mm}$

$$n = \frac{bV}{t} + m = \frac{40}{3,43} + 1,5 = 13,16 \text{ bars}$$

$$W_{\text{real}} = \frac{b \times h^2}{6} \times n = \frac{0,5 \times 8^2}{6} \times 13,16 = 70,19 \text{ cm}^3$$

$$\sigma = \frac{\max. M}{W_{\text{real}}} = \frac{725}{70,19} = 10,33 \text{ kN/cm}^2 < 16,0 \text{ kN/cm}^2$$

deflection

$$f = \frac{F_p}{384 \times E \times I_{\text{real}}} (8L^3 - 4L \times bT^2 + bT^3)$$

$$f = \frac{50}{384 \times 2,1 \times 10^4 \left(\frac{0,5 \times 8^3}{12} \times 13,16 \right)} (8 \times 68^3 - 4 \times 68 \times 20^2 + 20^3)$$

$$f = 0,05 \text{ cm} = \frac{1}{1360} \text{ of free span} < L/200$$

As calculation example shows, stress can be quite different depending on distance areas.

Closest to permissible stress is forge-welded grating, type **SP 580 - 34/38 - 5**.

Calculation example 2:**Uniformly distributed loading, imposed upon pressure-locked gratings**

Uniformly distributed loading	5,0 kN/m ²
Clear span	100 cm
Bearing bar pitch	3,33 cm
Cross bar pitch	3,33 cm

$$\max. M = \frac{F_v \times L}{8} = \frac{5,0 \times 100}{8} = 62,5 \text{ kNcm}$$

$$n = \frac{A}{L \times t} = \frac{1}{1,00 \times 0,0333} = 30 \text{ bars}$$

chosen: bearing bar ϕ 30 x 2 mm

$$W_{\text{real}} = \frac{b \times h^2}{6} \times n \times v = \frac{0,2 \times 3^2}{6} \times 30 \times 0,9 = 8,1 \text{ cm}^3$$

$$\sigma = \frac{\max. M}{W_{\text{real}}} = \frac{62,5}{8,1} = 7,72 \text{ kN/cm}^2 < 16,0 \text{ kN/cm}^2$$

deflection

$$f = \frac{5 \times F_v \times L^3}{384 \times E \times I_{\text{real}}}$$

$$f = \frac{5 \times 5,0 \times 100^3}{384 \times 2,1 \times 10^4 \left(\frac{0,2 \times 3^3}{12} \times 30 \times 0,9 \right)}$$

$$f = 0,26 \text{ cm} = \frac{1}{384} \text{ of free span} < L/200$$

Calculation example 3:**Point load imposed upon pressure-locked gratings**

Point load	1,5 kN
Clear span	100 cm
Contact area	20 x 20 cm
Bearing bar pitch	3,33 cm
Cross bar pitch	3,33 cm

$$\max. M = \frac{F_p \left(L - \frac{b}{2} \right)}{4} = \frac{1,5 \left(100 - \frac{20}{2} \right)}{4} = 33,75 \text{ kNcm}$$

chosen: bearing bar ϕ 30 x 2 mm

$$n = \frac{\text{load width}}{\text{bearing bar pitch}} + m = \frac{20}{3,33} + 3,17 = 9,17 \text{ bars}$$

$$W_{\text{real}} = \frac{b \times h^2}{6} \times n \times v = \frac{0,2 \times 3^2}{6} \times 9,17 \times 0,9 = 2,47 \text{ cm}^3$$

$$\sigma = \frac{\max. M}{W_{\text{real}}} = \frac{33,75}{2,47} = 13,66 \text{ kN/cm}^2 < 16,0 \text{ kN/cm}^2$$

deflection

$$f = \frac{F_p}{384 \times E \times I_{\text{real}}} (8L^3 - 4L \times bT^2 + bT^3)$$

$$f = \frac{1,5 (8 \times 100^3 - 4 \times 100 \times 20^2 + 20^3)}{384 \times 2,1 \times 10^4 \left(\frac{0,2 \times 3^3}{12} \times 9,17 \times 0,9 \right)}$$

$$f = 0,39 \text{ cm} = \frac{1}{256} \text{ of free span} < L/200$$

The grating type **P 230 - 33 - 3** may be considered.

Even though calculated stress values may be less than 16,0 kN/cm², allowing greater spans to be considered, they will be limited by the maximum permissible deflection and vice versa.



B Static Calculations

Calculation example: Perforated metal planks

Calculation of moments of inertia and resistance for a special pattern

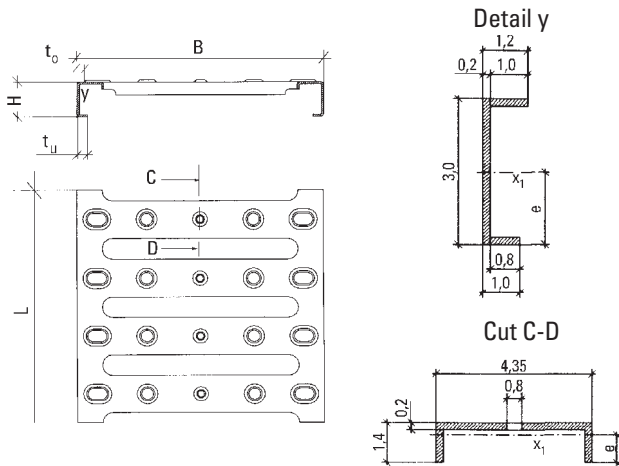

Determination of center of gravity for cut C - D

$$\begin{aligned}
 x_s &= \frac{(A_1 \cdot x_1) 2 + A_2 \cdot x_2}{A_1 + A_1 + A_2} \\
 &= \frac{(1,4 \cdot 0,2 \cdot 0,7) 2 + 3,15 \cdot 0,2 \cdot 1,3}{1,4 \cdot 0,2 + 1,4 \cdot 0,2 + 3,15 \cdot 0,2} \\
 &= \frac{1,211}{1,19} \\
 &= \mathbf{1,017 \text{ cm}} \\
 I_1 &= (I + A \cdot a_1^2) 2 = \left(\frac{b \cdot h^3}{12} + A \cdot a_1^2 \right) 2 \\
 &= \left(\frac{0,2 \cdot 1,4^3}{12} + 0,2 \cdot 1,4 \cdot 0,317^2 \right) 2 = 0,1477 \text{ cm}^4 \\
 I_{x2} &= \frac{3,15 \cdot 0,2^3}{12} + 3,15 \cdot 0,2 \cdot 0,283^2 = 0,0525 \text{ cm}^4 \\
 I_{x \text{ total}} &= \mathbf{0,200 \text{ cm}^4} \\
 W &= \frac{I_{x \text{ total}}}{e} \\
 &= \frac{0,20}{1,017} \\
 &= \mathbf{0,1969 \text{ cm}^3}
 \end{aligned}$$

Calculation in direction of „B“

$$\begin{aligned}
 x_s &= \frac{A_1 \cdot x_1 + A_2 \cdot x_2 + A_3 \cdot x_3}{A_1 + A_2 + A_3} \\
 &= \frac{0,2 \cdot 0,8 \cdot 0,1 + 0,2 \cdot 3 \cdot 1,5 + 0,2 \cdot 1,0 \cdot 2,9}{0,2 \cdot 0,8 + 0,2 \cdot 3 + 0,2 \cdot 1,0} \\
 &= \frac{1,496}{0,96} \\
 &= \mathbf{1,558 \text{ cm}} \\
 I_{x1} &= (I + A \cdot a_1^2) 2 = \left(\frac{b \cdot h^3}{12} + A \cdot a_1^2 \right) 2 \\
 &= \left(\frac{0,8 \cdot 0,2^3}{12} + 0,8 \cdot 0,2 \cdot 1,458^2 \right) 2 = 0,6813 \text{ cm}^4 \\
 I_{x2} &= \left(\frac{0,2 \cdot 3^3}{12} + 0,2 \cdot 3 \cdot 0,058^2 \right) 2 = 0,9040 \text{ cm}^4 \\
 I_{x3} &= \left(\frac{1,0 \cdot 0,2^3}{12} + 1,0 \cdot 0,2 \cdot 1,342^2 \right) 2 = 0,7217 \text{ cm}^4 \\
 I_{x \text{ total}} &= \mathbf{2,307 \text{ cm}^4} \\
 W &= \frac{I_{x \text{ total}}}{e} \\
 &= \frac{2,307}{1,558} \\
 &= \mathbf{1,4807 \text{ cm}^3}
 \end{aligned}$$



Calculation example 5

$$\begin{aligned} B = L_1 &= 200 \text{ mm} \\ H &= 30 \text{ mm} \\ s &= 2 \text{ mm} \\ L &= 600 \text{ mm} \end{aligned}$$

$$\begin{aligned} \text{Material} &= \text{S 235 JR} \\ \sigma &= 16 \text{ kN/cm}^2 \\ \text{Point load} &= 1,5 \text{ kN} \\ \text{Load area} &= 200 \times 200 \text{ mm} \end{aligned}$$

Calculation in direction of „B“

$$n_2 = \frac{b_L}{t} = \frac{200}{62,5} = 3,2 \text{ Bridges}$$

$$\text{max. M} = \frac{F_p \cdot (L_1 - \frac{b_B}{2})}{4} = \frac{1,5 \cdot (20 - \frac{20}{2})}{4} = 3,75 \text{ kNcm}$$

$$\begin{aligned} \sigma &= \frac{\text{max. M}}{W \cdot n_2} = \frac{3,75}{0,1969 \cdot 3,2} \\ &= 5,95 \text{ kN/cm}^2 < 14,0 \text{ kN/cm}^2 \end{aligned}$$

Calculation in direction of „L“

$$n_1 = 1 \text{ with elements } 200 \text{ and } > 200 \text{ wide, providing Sigma in direction B } < \text{Sigma } 16,0 \text{ kN/cm}^2$$

$$\text{For elements } < 200 \text{ is } n_1 = \frac{200}{B}$$

$$\text{max. M} = \frac{F_p \cdot (L - \frac{b_L}{2})}{4 \cdot n} = \frac{1,5 \cdot (60 - \frac{20}{2})}{4 \cdot 1}$$

$$= 18,75 \text{ kNcm}$$

$$\begin{aligned} \sigma &= \frac{\text{max. M}}{W} = \frac{18,75}{1,4807} \\ &= 12,66 \text{ kN/cm}^2 < 16,0 \text{ kN/cm}^2 \end{aligned}$$

$$\begin{aligned} f &= \frac{F_p}{384 \cdot E \cdot I_{x \text{ total}}} (8 L^3 - 4 L b_L^2 + b_L^3) \\ &= \frac{1,5}{384 \cdot 2,1 \cdot 10^4 \cdot 2,307} (8 \cdot 60^3 - 4 \cdot 60 \cdot 20^2 + 20^3) \\ &= \mathbf{0,132 \text{ cm}} \end{aligned}$$

Calculation example 6

$$\begin{aligned} B = L_1 &= 200 \text{ mm} \\ H &= 30 \text{ mm} \\ s &= 2 \text{ mm} \\ L &= 1100 \text{ mm} \end{aligned}$$

$$\begin{aligned} \text{Material} &= \text{S 235 JR} \\ \sigma &= 16 \text{ kN/cm}^2 \\ \text{Uniformly distributed load } F_v &= 5,0 \text{ kN/m}^2 \end{aligned}$$

Calculation in direction of „B“

$$\begin{aligned} n_2 &= \frac{A}{B \cdot t} = \frac{1}{0,2 \cdot 0,065} \\ &= 76,68 \text{ webs} \end{aligned}$$

$$\begin{aligned} \text{max. M} &= \frac{F_v \cdot L_1}{8 \cdot n_2} = \frac{5,0 \cdot 20}{8 \cdot 76,68} \\ &= 0,163 \text{ kNcm} \end{aligned}$$

$$\begin{aligned} \sigma &= \frac{\text{max. M}}{W_x} = \frac{0,163}{0,1969} \\ &= 0,82 \text{ kN/cm} < 16 \text{ kN/cm}^2 \end{aligned}$$

Calculation in direction of „L“

$$\begin{aligned} n_1 &= \frac{A}{L \cdot B} = \frac{1}{1,1 \cdot 0,2} \\ &= 4,54 \text{ elements} \end{aligned}$$

$$\begin{aligned} \text{max. M} &= \frac{F_v \cdot L}{8 \cdot n_1} = \frac{5,0 \cdot 110}{8 \cdot 4,54} \\ &= 15,14 \text{ kNcm} \end{aligned}$$

$$\begin{aligned} \sigma &= \frac{\text{max. M}}{W_x} = \frac{15,14}{1,4807} \\ &= 10,22 \text{ kN/cm}^2 < 14,0 \text{ kN/cm}^2 \end{aligned}$$

$$\begin{aligned} f &= \frac{5 \cdot F_v \cdot L^3}{384 \cdot E \cdot I_{x \text{ total}}} \\ &= \frac{5 \cdot 5,0 \cdot 110^3}{384 \cdot 2,1 \cdot 10^4 \cdot 2,307 \cdot 4,54} \\ &= \mathbf{0,39 \text{ cm}} \end{aligned}$$

The max. span of unscrewed elements is 1100 mm, otherwise the deflection is excessive.

SP Production

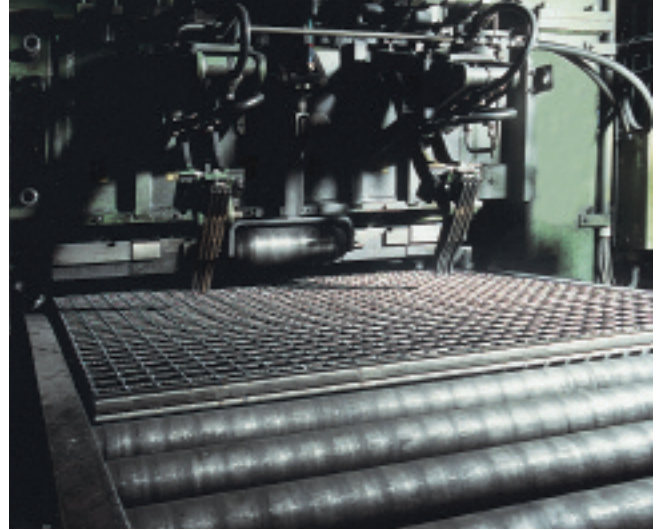

P Production



B Production





SP P Notes for invoice

Complete rectangular areas that are required to produce the final grating shape, including those areas cut from them, form the basis for calculation of gratings, in accordance with „Arbeitsgemeinschaft Industriebau e.V. (AGI)“.

Calculations are:

- manufactured area in terms of the smallest rectangle or square required in m², to produce the final grating size;
- cutouts for access and penetrations;

- matching the pattern on adjacent gratings
- quantity of binding bar for cutouts, in rm
- quantity of binding bar up to 0,5 rm for small cutouts at a unit price per rm and additional prices for individual pieces.
- additional prices for such items as kick flat (toe-plate), deep binding bar, perforated nosing, side plates, fixings, etc., will be charged in accordance with agreed unit price rates.

tes.

- The part list (confirmation of order), grating layout drawings and/or the final measurement, will form the basis of the invoice.

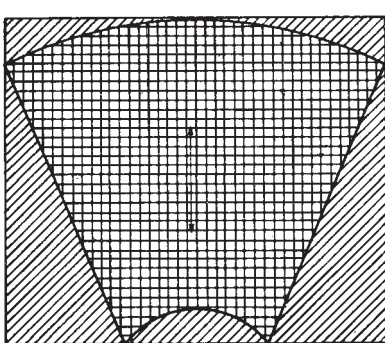
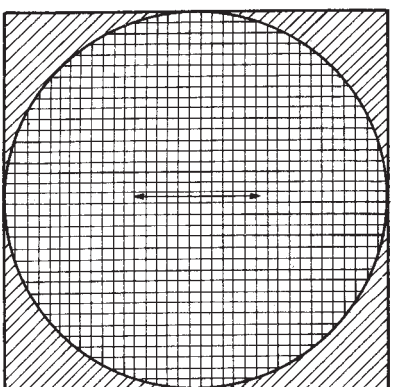
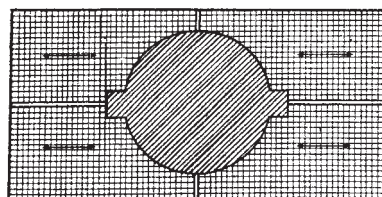
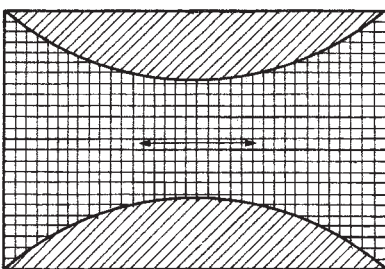
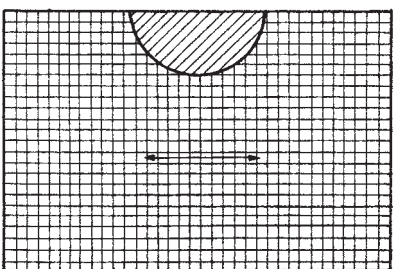
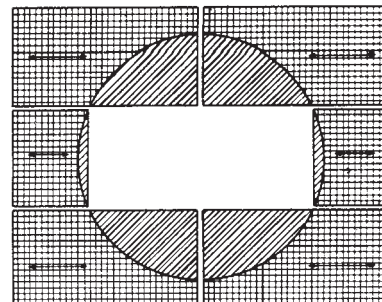
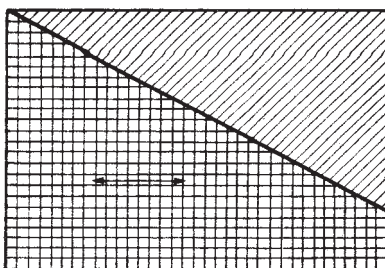
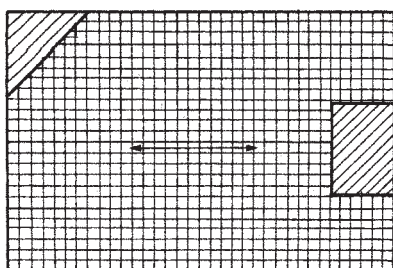

Legend

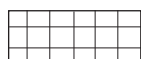

Actual fabricated area



Additional area to be included in calculations



Area not to be calculated



Bearing bar direction

Because each grating is originally manufactured in a rectangular shape, the above drawings show the minimum additional material that has to be manufactured, in order to be able to produce the actual fabricated area.

For perforated metal planks, the running metres will be calculated to suit production requirements (for perforated metal plank module figures, see pages 43 to 45 inc.).

Calculations are:

- The number of individual gratings required in accordance with the part list (confirmation of order) and/or the grating layout plan which necessary for production in line with agreed prices either per sq.m. or rm.

The prices per rm or sq.m. are based upon grating lengths required to suit module sizes. With varying lengths, the nearest size above to suit the module size will be charged for.

The module sizes are:

- BZ 90 mm and
- BP, BR, BP-Ü, BN-O and BN-G 125 mm.

In addition:

- Cutouts for access and penetrations;

- Matching the pattern/type on adjacent planks
- Quantity of binding bar for special shape cutouts, in rm
- Additional prices for such items as kick flat (toe-plate), deep binding bar, reinforcement of binding bar with angles, perforated nosing, side plates, fixings, etc., will be supplied in accordance with agreed unit price rates.

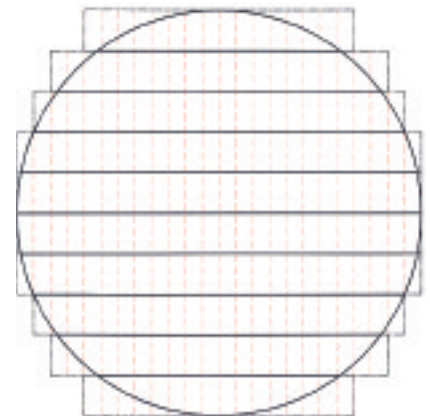
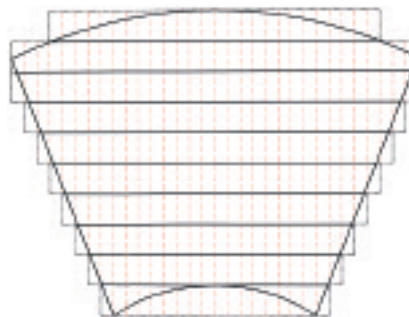
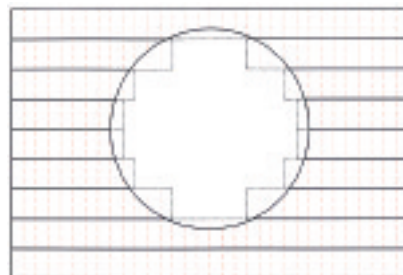
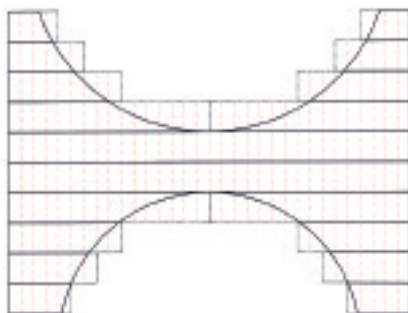
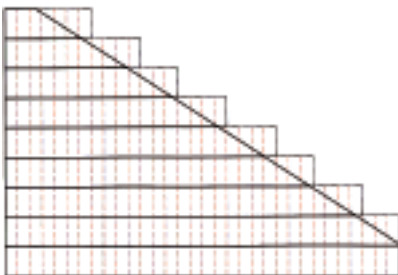

- finished outline
- necessary outline
- - - forward feed-module R

Lichtgitter products are usually supplied via forwarding agencies with whom we hold special contracts, however, supplies are also possible on an 'ex works' basis, upon request.

Standard packaging is provided where pallets cannot be returned or remain on site. This form of packing is sufficient for transport via lorry even if travelling abroad, and enables safe transportation with no damage sustained.

Depending on destination, products for export purposes will be packed in a special way:

- Screw-bundling
- Packing-cases
- Container.



Packaging

SP P Enquiry-/Order Form

(Stamp of Company / Address)

Date:

Contact:.....

Enquiry

Order:

Delivery date:

- Load:** Pedestrian traffic Vehicle traffic with kN wheel load
 Load area:..... kN/m²
- Surface:** Standard Serrated finish no.... Serration class R
 (see page 73)
- Material:** Steel S235JR (St 37-2) S355J2G3 (St 52-3) S355J2G3 (St 52-3) Stainless steel 1.4301 1.4571 Aluminium AIMg 3 G 22 AIMg 1 F 15
- Surface treatment:** galvanised galvanised pickled pickled
 galvanised and bitumen dip galvanised and bitumen dip electrochemically anodised
 galvanised and baked paint (colour acc. to RAL) galvanised and baked paint (colour acc. toRAL) polished plastic-laminated
 self-coloured self-coloured glass bead blasting process

Clear span:..... Pitch:

Grating type:

Pos.-No. gratings	Quantity	Bearing bar dim. Size of grating	Cross bar dim. Size of gratingparts	Extras or specialties (e.g. fixings)
.....
.....
.....

Pos.-No.	Number of treads	Bearing bar dim.	Cross bar dim.	Fixings for stairtreads
.....
.....

Alternatively estimated quantities

- Total quantity sqm
 rm of cutouts rm
 Extra for small cutouts having less than 0,5 rm of binding bar each
 Raised flat binding bar to serve as kick flat rm
 Perforated nosing rm
 Anti-slip profile U 20/20/20/2,0 rm
 Fixings set
 Special parts

- Layout plan** as per sketch as per steel structure drawings via data transmission via E-mail-transmission
- YES NO
- Packaging:** One-way-palettes Screw bundling Packing cases Container

Notes:

(Stamp of Company / Address)

Date:

Contact:.....

Enquiry:

Order:

Delivery date:

Load: Pedestrian traffic Vehicle traffic kN wheel load Load area : kN/m²

Pattern: BZ BP BR BP-Ü BN-0 BN-G

Serration:
 → serration class R
 (see page 73)

Material: Steel S235JR (St 37-2) Stainless steel 1.4301 1.4571 Aluminium AIMg 3 G 22

Surface treatment: galvanised galvanised and bitumen dip galvanised and baked paint pre-galvanised self-coloured pickled electrochemically polished self-coloured pickled anodised plastic-laminated

Clear span: mm

Indication of element:

Pos.-No.	Number of elements	Dimension „L“ Element length	Dimension „B“ Element width	Extras or specialties
.....				
.....				
.....				

Pos.-No.	Number of treads	Dimension „L“	Dimension „B“	Fixings for stairtreads
.....				
.....				

Alternatively estimated quantities

Total quantity sqm
 rm cutouts rm
 Extra for small cutouts having less than 0,5 rm of binding bar each
 Raised flat binding bar to serve as kick flat rm
 Perforated nosing rm
 Fixings set
 Special parts

Layout plan as per sketch as per steel structure drawings via data transmission via E-mail-transmission

YES NO

Packaging: One-way-pallettes Screw bundling Packing cases Container

Notes:

.....



Main Works Stadtlöhn

Lichtgitter Gesellschaft mbH
Siemensstraße
48703 Stadtlöhn
Telephone: +49/2563 / 911-0
Telefax: +49/2563 / 911-118
E-mail: info@lichtgitter.de
Internet: <http://www.lichtgitter.de>

Works Sulz

Lichtgitter Gesellschaft mbH
Werk Sulz
Bahnhofstraße 76
72172 Sulz/Neckar
Telephone: +49/7454 / 95 82-0
Telefax: +49/7454 / 95 82-49
E-mail: sulz@lichtgitter.de

Works Blumberg

Lichtgitter Gesellschaft mbH
Werk Blumberg
Schönower Straße 6
16306 Casekow OT Blumberg
Telephone: +49/33331 / 797-0
Telefax: +49/33331 / 797-55
E-mail: blumberg@lichtgitter.de

Subsidiaries

Suomen Teräsrilä, Finland
Le Caillebotis Diamond, France
CSE Lichtgitter, France
Lichtgitter U.K., Great Britain
Las Pers, Netherlands
Dejo Metaalindustrie, Netherlands
Lichtgitter Service Center OTW, Austria
Stegerud Steel, Sweden
Lichtgitter Anton Ruppli, Switzerland
Lichtgitter Slovakia, Slovakia
Lichtgitter CZ, Czech Republic
Lichtgitter Izgara, Turkey
Lichtgitter Baltija, Baltic States and area
of Kaliningrad
Lichtgitter Bulgaria, Bulgaria

Representatives

Denmark
Greece
Indonesia
Italy
Malaysia
Norway
Poland
Singapore
Spain

Products

Forge-welded Gratings
Pressure-locked Gratings
Perforated Metal Planks
Spiral Staircases

Heavy Duty Gratings
Offshore Gratings
Aluminium Gratings
Stainless Steel Gratings
GRP Gratings

Acknowledgement

This manual includes information from DIN, BG, RAL and AGI. And we are grateful to the relevant authorities for permission to reproduce these.

Technical specification and concept

Lichtgitter Gesellschaft mbH. All technical specifications and data correct at time of going to press. We reserve the right to alter these specifications and details where necessary, and without prior notice. Protection notice acc. DIN 34. In case of any queries, please do not hesitate to contact us.



Head Office Stadtlohn

Lichtgitter Gesellschaft mbH

Siemensstraße

48703 Stadtlohn

Telephone: +49/2563 / 911-0

Facsimile: +49/2563 / 911-118

E-mail: info@lichtgitter.de

Internet: <http://www.lichtgitter.de>

Works Sulz

Lichtgitter Gesellschaft mbH Werk Sulz

Bahnhofstraße 76

72172 Sulz/Neckar

Telephone: +49/7454 / 95 82-0

Facsimile: +49/7454 / 95 82-49

E-mail: sulz@lichtgitter.de

Works Blumberg

Lichtgitter Gesellschaft mbH Werk Blumberg

Schönowe Straße 6

16306 Casekow OT Blumberg

Telephone: +49/33331 / 797-0

Facsimile : +49/33331 / 797-55

E-mail: blumberg@lichtgitter.de